



15

# Stirred Reactors and Pressure Vessels



Designing and Building Quality Pressure Apparatus for 120 Years



Founded in 1899  
by University of Illinois  
Professor S.W. Parr,  
Parr Instrument Company  
has consistently strived  
to provide for its customers  
the very best in product,  
service and support.



## Parr Instrument Company

**W**elcome to the Fifteenth Edition of the Parr Stirred Reactor and Pressure Vessel Catalog. We proudly present here our latest catalog describing the continued expansion of this product line. New products, new designs, and expanded options are offered; all backed by Parr's continuing dedication to product quality, safety, and customer satisfaction. We hope you will find this new catalog to be a useful tool.

211 Fifty-third Street

Moline, Illinois 61265 USA

Phone: 1-309-762-7716

1-800-872-7720

Fax: 1-309-762-9453

Email: [parr@parrinst.com](mailto:parr@parrinst.com)

web: [www.parrinst.com](http://www.parrinst.com)

# Table of Contents

Introduction . . . . .	2				
The User's Responsibility . . . . .	6				
<b>1 : Design Features</b>	<b>7</b>				
Design Codes and Certification . . . . .	8				
Materials of Construction . . . . .	10				
Pressure and Temperature Limits . . . . .	13				
High Torque Magnetic Drives . . . . .	14				
Split-Ring Closures . . . . .	16				
Gaskets and Seals . . . . .	18				
Mounting Styles . . . . .	20				
Warranty . . . . .	22				
<b>2 : Stirred Reactors</b>	<b>23</b>				
Reactor Selection Guide . . . . .	24				
How to use Ordering Guide . . . . .	27				
Series 4520 1-2 L Bench Top Reactors . . . . .	28				
Series 4530 1-2 L Floor Stand Reactors . . . . .	32				
Series 4540 600-1200 mL HP Reactors . . . . .	36				
Series 4550 1-2 Gallon Reactors . . . . .	40				
Series 4555 2.6-5 Gallon Floor Stand Reactors . . . . .	44				
Series 4560 Mini Reactors . . . . .	48				
Series 4570-4580 HT/HP Reactors . . . . .	52				
Series 4590 Micro Reactors . . . . .	56				
Series 5100 Glass Reactors . . . . .	60				
Series 5500 HP Compact Reactors . . . . .	64				
<b>3 : Multiple Reactors</b>	<b>67</b>				
Series 5000 Multiple Reactor System (MRS) . . . . .	68				
Series 2500 Micro Batch Reactor System . . . . .	72				
Parallel Reactor Systems . . . . .	74				
<b>4 : Tubular Reactors</b>	<b>77</b>				
Series 5400 Continuous Flow Tubular Reactors . . . . .	78				
Fluidized Bed Reactors . . . . .	84				
<b>5 : Specialty and Custom Reactor Systems</b>	<b>87</b>				
Introduction to Specialty and Custom Reactors . . . . .	88				
Biofuels and Alternative Fuels Research Systems . . . . .	89				
Horizontal Reactors . . . . .	90				
Rotating Cage Apparatus . . . . .	92				
A1000G Tri-Axial Core Holder . . . . .	93				
Supercritical Fluids . . . . .	94				
GTL (Gas-To-Liquid) System . . . . .	95				
Other Specialty and Custom Reactor Systems . . . . .	96				
<b>6 : Controllers</b>	<b>99</b>				
Controller Overview . . . . .	100				
Series 4848 Reactor Controllers . . . . .	102				
Series 4848T Touchscreen Reactor Controller . . . . .	105				
Series 4838 Temperature Controller . . . . .	107				
SpecView Software for 4848 & 4838 Controllers . . . . .	108				
Series 4871 Process Controllers . . . . .	109				
Series 4875 Power Controller . . . . .	113				
Series 4876 Power Controllers . . . . .	113				
4877 Valve Controller . . . . .	114				
A2200E Flow Controller . . . . .	114				
A2110E Motor Controller . . . . .	114				
<b>7 : Optional Accessories</b>	<b>115</b>				
Heaters . . . . .	116				
Stirring Motors and Drives . . . . .	118				
Stirrer Options . . . . .	120				
Gas Entrainment . . . . .	121				
Catalyst Baskets . . . . .	122				
Condensers . . . . .	123				
Safety Rupture Discs . . . . .	124				
Pressure Relief Valves and Gages . . . . .	125				
Gas Measurement Systems . . . . .	126				
Liquid Charging Systems . . . . .	127				
Solids/Slurry Addition Devices . . . . .	128				
Cooling Coils . . . . .	129				
Cylinder Liners . . . . .	129				
Liquid Sampling . . . . .	130				
Sample Collection Vessels . . . . .	130				
4878 Automated Liquid Sampler . . . . .	130				
Filtered Dip Tubes . . . . .	130				
Catalyst Testing System . . . . .	131				
Bottom Drain Valves . . . . .	131				
Valves and Fittings . . . . .	132				
Pressure Hoses . . . . .	133				
Thermocouples . . . . .	133				
Equipment for Use in Potentially Ignitable Atmospheres . . . . .	134				
Windows . . . . .	136				
Insulated Electrical Glands . . . . .	137				
Spare Parts Kits . . . . .	137				
Temperature Limits . . . . .	138				
External Valves and Fittings . . . . .	138				
<b>8 : Non-Stirred Vessels</b>	<b>139</b>				
Introduction . . . . .	140				
Series 4700 Pressure Vessels, 22 & 45 mL . . . . .	142				
Series 4740 HP/HT Pressure Vessels, 25 & 75 mL . . . . .	144				
Series 4750 General Purpose Pressure Vessels, 125 & 200 mL . . . . .	146				
Series 4790 Pressure Vessels, 25-100 mL . . . . .	148				
Series 4760 Pressure Vessels, 100-600 mL . . . . .	152				
Series 4600 Pressure Vessel Systems, 1 & 2 Liter . . . . .	156				
Series 4625 High Pressure Vessel Systems, 600 & 1200 mL . . . . .	160				
Series 4650 High Pressure / High Temperature Vessel Systems . . . . .	162				
Series 4660 Pressure Vessel Systems, 1 & 2 Gallon . . . . .	164				
Series 4680 High Pressure / High Temperature Vessel Systems, 1 & 1.8 Liters . . . . .	166				
Series 4670 HP-HT Vessel Systems, 1 and 1.5 Gallon . . . . .	168				
Series 4675 General Purpose Vessel Systems, 2.6 & 5 Gallon . . . . .	170				
Gage Block Assemblies . . . . .	173				
Coned Pressure Fittings . . . . .	173				

## Some of the things that

make Parr Instrument Company the world leader in laboratory equipment cannot be easily shown in a catalog. We refer here to the long-established practices and policies of Parr that have helped to build our reputation as a reliable supplier in our specialized field, such as:

## Support



**A technical sales and support staff** with an average of over 20 years of experience in this specialized field. We have “been there and done that” and we are looking forward to helping you solve your unique requirements.

## Communication

**A commitment to listen to our customers** and a willingness to make the additions or changes in a reactor or pressure vessel that the customer may want or need. Approximately 40 percent of all the reactors and vessels we ship are modified in some way over-and-above the options listed in this catalog. Specialty valves, custom head layouts, electrical leads, special stands, additional openings, unique motors, and non-standard materials of construction are just a few of the modifications we work with every day.



**www.parrinst.com** is continually updated to provide you with 24 hours access to a more extensive discussion of our products and capabilities. Look for our online resources to expand as we strive to continue to provide you with the world class experience you have come to expect from Parr Instrument Company.



## Investment

**An investment in modern machine tools and superior production management methods** enables us to make available not only all of the options listed on the following pages, but also to handle custom orders for one-of-a-kind designs along with regular production orders on a routine basis.



## Research

**A commitment** to new materials, manufacturing methods, research disciplines, and technological advances to continue our leadership position.

## Service

**A commitment** to maintain commonly used replacement and service parts in stock for next day shipment.



## Delivery

**A commitment to prompt and dependable delivery schedules** for not only catalog items, but also for custom equipment as well. Typical delivery time for catalog reactors constructed of stainless steel is about six weeks. For reactors made of special alloys or including custom features, lead time will be extended based on the complexity of the customization. Of equal importance over the life of your reactor is our commitment to maintain commonly used replacement and service parts in stock for next day shipment.



## At Parr Instrument Company,

we never rest on our past successes. We are constantly working to further improve our products and to streamline our processes. We continue to lead the industry in innovation, safety, and reliability. Researchers from around the world rely on Parr's scientific and engineering design expertise. We are continually expanding our expertise for designing and developing custom systems. From single units to complex multi-reactor systems, we can help find a solution for your research needs.



**Our innovative horizontal stirred reactors can be designed to load vertically and operate in either the vertical or horizontal position. The tilt mechanism can be manual or automated. The options are only limited by your design requirements.**



**Temperature, pressure, stirred or non-stirred, options such as windows for measurement or observation, we can build one for you.**



**Six reactor 4590-based multi-reactor with automated sampling. [See page 76.](#)**



**Hinged Split-Rings.** Available on many of our larger Reactor Systems throughout this catalog.

# The User's Responsibility

All Parr reactors and pressure vessels are designed and manufactured with great care to ensure safe operation when used within their prescribed temperature and pressure limits. But, the basic responsibility for safety when using this equipment rests entirely with the user; who must:

**1. Select a reactor or pressure vessel** which has the capability, pressure rating, corrosion resistance and design features that are suitable for its intended use. Parr engineers will be glad to discuss available equipment and material options with prospective users, but the final responsibility for selecting a reactor or pressure vessel that will perform to the user's satisfaction in any particular reaction or test must rest with the user — not with Parr.

In exercising the responsibility for the selection of pressure equipment, the prospective user is often faced with a choice between over or under-designed equipment. The hazards introduced by under-designed pressure vessels are readily apparent, but the penalties that must be paid for over-designed apparatus are often overlooked.

Recognizing these criteria, Parr reactors and pressure vessels are offered in several different styles, each designed for convenient use in daily operation within certain temperature and pressure limits, using gaskets, closures and other elements carefully selected for safe operation within the limits specified for that design. But in order to preserve the validity of these designs, all temperature and pressure limits must be observed, and no attempt should be made to increase these limits by making alterations or by substituting components which are not recommended by Parr Instrument Company.

**2. Install and operate the equipment** within a suitable barricade, if required, with appropriate safety accessories and in full compliance with local safety codes and rules.

All standard Parr reactors and pressure vessels are provided with either a suitable relief device or a means to attach one (typically in the form of a plugged opening). When a pressure vessel is delivered without a pressure relief device, it is the customer's responsibility to provide pressure relief in order to protect the operator and the equipment from destructive high pressures. If you need more information or need help in selecting a proper relief device, please contact Parr Instrument Company.

**3. Establish training procedures** to ensure that any person handling the equipment knows how to use it properly.

**4. Maintain the equipment** in good condition and establish procedures for periodic testing to be sure the vessel remains structurally sound.



# Design Features Chapter 1



## Design Codes

## Certification

## Quality Assurance:

- [ISO 9001: 2015](#)
- [ASME](#)
- ["R" Symbol](#)
- [PED](#)
- [PARR](#)
- [CSA](#)
- [TPS ACT](#)
- [CE](#)

## Materials of Construction

- [Alloy Designations](#)

## Pressure and Temperature Limits

## Magnetic Drives

## Split-Ring Closures

## Gaskets & Seals

## Mounting Styles

# Design Codes and Certification



## Commitment to a Worldwide Market

In 1973, Parr Instrument Company made a commitment to serve customers on a worldwide basis in a reliable and continuing manner. Parr products were exhibited for the first time at Achema in Frankfurt, Germany that year. An extensive effort was initiated to select and train a network of local agents to provide technical sales and service support as well as import services in each of the countries where modern chemical research and development is conducted.

In 1982, Parr Instrument Company was awarded the President's E Award for Excellence in Exporting in recognition of our successful efforts in this area. In 1988, Parr was awarded the U.S. Department of Commerce's highest level award the President's E Star Award for Excellence in Exporting in recognition of our continuing and accelerating success in servicing the world market.

Today, Parr pressure reaction equipment is in use in over 80 countries and active exclusive agents are operating in 28 of these. Today, over half of all Parr pressure reaction equipment is exported from the USA. As a part of this expansion in the world market, international considerations are designed into, not added onto, all Parr equipment.

## Design criteria specified in the ASME Code for Unfired Pressure Vessels are closely observed in the manufacture and testing of all Parr pressure equipment.

Cylinders for each reactor and pressure vessel of standard design are machined from solid, hot-rolled or forged bars of selected corrosion resistant alloys with no seams or welds in the vessel as potential sources of weakness or localized corrosion. Each individual cylinder is tested hydrostatically. For vessels bearing ASME Certification Mark with "U" Certification designator, the minimum hydrostatic test pressure is 1.3 times the rated working pressure corrected for temperature. For CE marked pressure vessels the minimum hydrostatic test pressure is the higher of 1.43 times the rated working pressure or 1.25 times the rated working pressure corrected for temperature. Each complete reactor and vessel assembly is further tested with nitrogen to be sure that it is leak-free and operating properly.

Protection against equipment damage and possible personal injury in case of an accidental over-pressurization is typically provided by a safety rupture disc installed in the head of a reactor or in a gage block assembly mounted on the head. A description of these safety discs and rules to be observed in their selection and use are given on [page 124](#).

## Quality Assurance

Parr Instrument Company has designed, installed and operates under a Quality Assurance Program which ensures that all aspects of the design, materials selection and procurement, manufacture, testing and certification of its pressure vessels are performed in accordance with accepted codes and practices. Currently this Quality Assurance Program has been certified to be in compliance with ISO 9001: 2015 for Total Quality Procedures, ASME, CSA (Canadian Standards Association), and all applicable European Directives (CE) which include but are not limited to PED (Pressure Equipment Directive), LVD (Low Voltage Directive), EMC (Electromagnetic compatibility), and Machinery Safety.

## ISO 9001: 2015 Certification

Parr Instrument Company's overall Quality Assurance System has been certified to be in compliance with ISO 9001: 2015 by TÜV SÜD. ISO 9001: 2015 covers the overall quality assurance and management compliance aspects of Parr's activities as opposed to the certification of an individual product.

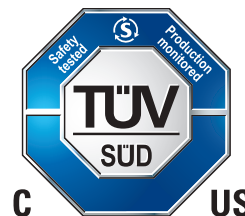

### ASME Certification

Parr Instrument Company holds a Certificate of Authorization issued by the Boiler and Pressure Vessel Committee of the American Society of Mechanical Engineers (ASME) and the National Board of Boiler & Pressure Vessel Inspectors (NBBI) as an approved facility for manufacturing unfired pressure vessels. If required, any Parr reactor or pressure vessel can be certified to the ASME BPVC, Section VIII, Division 1, which involves:

1. Vessel inspection and tests by an Authorized Inspector of the National Board of Boiler and Pressure Vessel Inspectors.
2. Issuance of Form U-1 or U-1A, "Manufacturer's Data Report for Pressure Vessels", which provides all relevant documentation of the finished vessel including certification of the chemical analysis and physical properties of materials used in the vessel.
3. Application of the ASME Certification Mark with "U" Certification Designator to the vessel by the Inspector.
4. Registration of the vessel with the National Board.

It should be noted that unless specifically requested, ASME certification provided by Parr will cover the vessel only and not the relief device. Parr can furnish certain relief devices with ASME certification upon request.

Parr is also certified under Section IX of the ASME Code for welding. Normally welding is done only to attach jackets or fittings to the primary vessel.

Parr Instrument Company is authorized to apply the "R" Symbol in accordance with the provisions of the National Board of Boiler and Pressure Vessel Inspectors for metallic repairs and/or alterations at its Moline, Illinois headquarters.

### PED Certification

Parr Instrument Company has implemented, operates and maintains a quality assurance system as described in the Pressure Equipment Directive Annex III, Module H/H1 for the scope of Design and Manufacture of Pressure Reactors and Assemblies for Laboratory Applications.

### Parr Certification

If requested, Parr will furnish a signed certificate listing the materials of construction used in the manufacture of an individual reactor or pressure vessel, the pressure tests applied to that reactor, material certificates and reference layout drawings.

### CSA Certification

Where appropriate, Parr reactors are manufactured and certified to the electrical code established by the Canadian Standards Association. Identification of those units for which CSA Certification has been received will be provided upon request. The CSA logo is shown on the nameplate of each CSA certified unit.

### TPS ACT Certification (CUE Mark)

Where appropriate, Parr reactors will carry the CUE mark of TPS (TÜV SÜD Product Service division) ACT (Acceptance of Client's Testing) certifying the manufacture and testing in compliance with mutually agreed product categories and/or standards, including the requirements of the current revision of ISO/IEC 17025, appropriate to applicable Canadian, US, and European market regulations.

### CE Certification

Where appropriate, Parr reactors will carry the CE Mark certifying compliance with all applicable European Community Directives.

### Other National or Local Codes

Parr regularly works with other national, state or international authorities to obtain individual approval for specific vessels. Parr has obtained CRN Approval for pressure vessels in Canadian provinces. The internationally recognized Quality Assurance Program in place at Parr and the experience of the Parr engineering department in working with these authorities makes it possible to obtain these approvals with little difficulty. It is the user's responsibility to identify any such applicable code so that these requirements can be met before the vessel is fabricated and delivered. Parr's network of international distributors are familiar with the applicable codes for pressure vessels within their countries of responsibility.



# Materials of Construction



**Parr reactors are normally made of Type 316 Stainless Steel**, but they can also be made of other alloys as well.

Available construction materials include:

- Type 316/316L Stainless Steel
- Alloy A-286
- Alloy 20
- Alloy 230
- Alloy 400
- Alloy 600
- Alloy 625
- Alloy B-2/B-3
- Alloy C-276
- Nickel 200
- Titanium Grades 2, 3, 4, & 7
- Zirconium 702 & 705
- Other material may be available upon request

---

***Parr Instrument Company will attempt to answer questions regarding corrosion resistance and may suggest materials that might be suitable for specific applications, but no guarantee can be made that any particular alloy will be fully resistant to a prescribed set of corrosive conditions.***

---

## **Alloy Designation**

Parr uses alloy designation numbers to identify the various corrosion resistant alloys available for use in Parr reactors and pressure vessels. These alloys can also be identified by trade names and by ASTM, ASME, DIN and other specification numbers. Many of the high nickel alloys were originally patented and sold under trade names, such as Monel<sup>1</sup>, Inconel<sup>1</sup>, Incoloy<sup>1</sup>, Carpenter Alloy 20<sup>2</sup>, Hastelloy<sup>3</sup>, etc. Most of the original patents have expired and these alloys are now available from other suppliers, as well as from the owners of the original trade names.

Among the many corrosion resistant alloys now available, there may be two or three with very similar compositions and intended for use in the same corrosive environment. In these cases, Parr will select and offer the most widely used alloy in each of the basic corrosion resistance categories, rather than catalog and stock all three.

Each of these alloys has its own physical strength and temperature characteristics as well as its own unique resistance to certain corrosive materials. All of these factors must be considered when making a selection, with cost and availability also becoming factors in the final choice.

The basic composition of these alloys is listed in [Table I](#). Corrosion resistance information can be obtained from various corrosion handbooks and metallurgical publications. Helpful information can also be obtained from the individual alloy manufacturers.

Any abridged listing of corrosion resistance of various metals and alloys can be potentially misleading since it cannot possibly deal with all of the effects of concentration, temperature, pressure and the presence of additional ions, all of which have a significant effect upon the ability of a reactor to withstand corrosion. In addition, the vulnerability

<sup>1</sup> MONEL, INCONEL and INCOLOY are Registered Trademarks of Special Metals Corp.

<sup>2</sup> CARPENTER 20 is a Registered Trademark of Carpenter Technology Corporation.

<sup>3</sup> HASTELLOY is a Registered Trademark of Haynes International, Inc.

of any material to stress corrosion cracking, intergranular corrosion and pitting must also be considered when judging the suitability of a material for a particular application.

The principal characteristics of the construction materials offered by Parr are summarized on the following pages. These listings are intended to serve only as a starting point for any study of comparative corrosion resistance and physical properties. Material manufacturers booklets on each alloy are available on our website at [www.parrinst.com](http://www.parrinst.com). Additional details may also be obtained from other sources.

### Type 316/316L Stainless Steel

Type 316 Stainless Steel is an excellent material for use with most organic systems. A few organic acids and organic halides can, under certain conditions, hydrolyze to form inorganic halogen acids which will attack T316SS. Acetic, formic and other organic acids are routinely handled in T316SS. T316SS is not normally the material of choice for inorganic acid systems. At ambient temperatures it does offer useful resistance to dilute sulfuric, sulfurous, phosphoric and nitric acids, but sulfuric, phosphoric and nitric acids readily attack T316SS at elevated temperatures and pressures. Halogen acids attack all forms of stainless steel rapidly, even at low temperatures and in dilute solutions.

Although T316SS offers excellent resistance to surface corrosion by caustics, they can cause stress corrosion cracking in stainless pressure vessels. This phenomenon begins to appear at temperatures just above 100 °C and has been the most common cause of corrosion failure in stainless laboratory vessels. T316SS does offer good resistance to ammonia and to most ammonia compounds.

Halogen salts can cause severe pitting in all stainless steels. Chlorides can cause stress corrosion cracking, but many other salt solutions can be handled in stainless vessels, particularly neutral or alkaline salts.

At moderate temperatures and pressures, T316SS can be used with most commercial gases. In scrupulously anhydrous systems even hydrogen chloride, hydrogen fluoride and chlorine can be used in stainless steel.

Essentially all of the T316SS produced today also meets the specifications for 316L, low carbon stainless steel.

### Alloy 20

Alloy 20 is an enriched grade of stainless steel, designed specifically for use with dilute (up to 30 percent by weight) sulfuric acid at elevated temperatures. It can also be used for nitric and phosphoric acid systems as well as for all systems for which T316SS is suitable.

### Alloy 400

Alloy 400 is an alloy comprised essentially of two-thirds nickel and one-third copper. For many applications it offers about the same corrosion resistance as nickel, but with higher maximum working pressures and temperatures and at a lower cost because of its greatly improved machinability.

Alloy 400 is widely used for caustic solutions because it is not subject to stress corrosion cracking in most applications. Chloride salts do not cause stress corrosion cracking in Alloy 400. It is also an excellent material for fluorine, hydrogen fluoride and hydrofluoric acid systems. Alloy 400 offers some resistance to hydrochloric and sulfuric acids at modest temperatures and concentrations, but it is seldom the material of choice for these acids. As would be expected from its high copper content, Alloy 400 is rapidly attacked by nitric acid and ammonia systems.

**All Parr raw materials are carefully identified throughout the manufacturing process for traceability — as required by ASME and other codes.**

*Continued, next page >*

**Table I Nominal Chemical Composition of Pressure Vessel Materials**

Material	Typical Trade Name	Major Elements (Percent)						Other
		Fe	Ni	Cr	Mo	Mn		
T316	Stainless Steel	65	12	17	2.5	2.0	Si 1.0	
Alloy 20	Carpenter 20	35	34	20	2.5	2.0	Cu 3.5, Cb 1.0 max	
Alloy 230	Haynes 230	3	52	22	2	0.7	Co-5, W-14, Si-0.5	
Alloy 400	Monel 400	2.5 max	63 min			2 max	Cu 31.5	
Alloy 600	Inconel 600	8	76	15.5				
Alloy 625 Gr 1	Inconel 625 Gr 1	5	58	22	9	0.5	Nb+Ta 3.7	
Alloy A-286	Alloy 286	53	25	15	1.2	2	Si-1, Ti-2.1, Al-0.35	
Alloy B-2/B-3	Hastelloy B-2/B-3	2	66	1	28	1	Co 1.0	
Alloy C-276	Hastelloy C-276	6.5	53	15.5	16	1	W4.0, Co 2.5	
Nickel 200			99					
Titanium Grade 2,3,4	Commercially pure titanium						Ti 99 mi	
Titanium Grade 7							Ti 98.8 min, 0.15 Pd	
Zirconium Grade 702							Zr + Hf 99.2 min, Hf 4.5 max	
Zirconium Grade 705							Zr + Hf 95.5 min, Hf 4.5 max, Nb 2.5	

---

# Materials of Construction

< *Continued, from previous page*

## **Alloy 600**

Alloy 600 is a high nickel alloy offering excellent resistance to caustics and chlorides at high temperatures and high pressures when sulfur compounds are present. In caustic environments, Alloy 600 is unexcelled. It also is often chosen for its high strength at elevated temperatures. Although it can be recommended for a broad range of corrosive conditions, its cost often limits its use to only those applications where its exceptional characteristics are required.

## **Alloy B-2/B-3**

Alloy B-2/B-3 is an alloy, rich in nickel and molybdenum, which has been developed primarily for resistance to reducing acid environments, particularly hydrochloric, sulfuric and phosphoric. Its resistance to these acids in pure forms is unsurpassed, but the presence of ferric and other oxidizing ions in quantities as low as 50 ppm can dramatically degrade the resistance of this alloy.

## **Alloy C-276**

Alloy C-276 is a nickel chromium-molybdenum alloy having perhaps the broadest general corrosion resistance of all commonly used alloys. It was developed initially for use with wet chlorine, but it also offers excellent resistance to strong oxidizers such as cupric and ferric chlorides, and to a variety of chlorine compounds and chlorine contaminated materials. Because of its broad chemical resistance, Alloy C-276 is the second most popular alloy, following T316SS, for vessels used in research and development work.

## **Nickel 200**

Nickel 200 is one of the designations of commercially pure nickel. It offers the ultimate in corrosion resistance to hot caustic environments, but its applications are severely restricted because of its poor machinability and resultant high fabrication costs.

## **Titanium**

Titanium is an excellent material for use with oxidizing agents, such as nitric acid, aqua regia and other mixed acids. It also offers very good resistance to chloride ions. Reducing acids, such as sulfuric and hydrochloric, which have unacceptably high corrosion rates in their pure form can have their corrosion rates in titanium reduced to acceptable levels if relatively small quantities of oxidizing ions, such as cupric, ferric, nickel or even nitric acid are present to act as corrosion inhibitors.

This phenomenon leads to many successful applications for titanium in the hydrometallurgy field where acids, particularly sulfuric acid, are used to leach ores. In these operations, the extracted ions act as corrosion inhibitors.

Prospective users must remember that titanium will burn vigorously in the presence of oxygen at elevated temperatures and pressures. While there have been many successful applications in hydrometallurgy where

oxygen and sulfuric acid are handled in titanium equipment, the danger of ignition is always present and must be protected against whenever titanium and oxygen are used together.

Commercially pure titanium is available in several grades. Grade 2 is the material most commonly used for industrial equipment since it can be fabricated by welding and can be used to make vessels compliant to the PED and ASME codes. Grade 4, which has slightly higher trace levels of iron and oxygen, has higher strength than Grade 2 but it is not suitable for welding and it is not covered by the PED or ASME Codes.

Since most Parr vessels are not welded, Grade 4 can be used to obtain higher working pressures than can be obtained with Grade 2. Grade 7, containing small amounts of palladium, and Grade 12 containing small amounts of nickel and molybdenum, offer enhanced resistance to certain environments and can be used for Parr reactors and pressure vessels if suitable billets can be obtained.

## **Zirconium**

Zirconium offers excellent resistance to hydrochloric and sulfuric acids, however, as with Alloy B-2/B-3, oxidizing ions such as ferric, cupric and fluorides must be avoided. Zirconium also offers good resistance to phosphoric and nitric acids, and to alkaline solutions as well. Two different grades are available: Grade 702 which contains hafnium is the standard commercial grade offering the best resistance to most corrosive agents. Grade 705 contains small amounts of both hafnium and niobium which increases the strength characteristics and allows for higher maximum working pressures for a vessel. Grade 702 typically offers better corrosion resistance than Grade 705. Grade 702 is also more widely available from commercial stocks of raw materials.

---

## **High Temperature / High Strength Alloys**

In addition to the metals chosen for their corrosion resistance Parr also offers some alloys that are selected for their outstanding strength values, their high temperature strengths, or both.

### **Alloy 230**

Alloy 230 is an alloy approved for ASME pressure vessel design for temperatures up to 980 °C. It is an alloy high in nickel, chromium, tungsten, and cobalt. While it has resistance similar to Alloy 600, it is normally selected for its high strengths at very high temperatures. It is sometime selected as a bolting material.

### **Alloy 625**

Alloy 625 is an alloy with chemical resistance similar to Alloy C-276, but with much greater strength. We use this alloy to obtain additional pressure ratings for high temperature applications.

### **Alloy A-286**

Alloy A-286 is an alloy of the Stainless Steel family with very high strengths up to 371 °C. It is commonly used as a bolting material.

## Pressure and Temperature Limits

The maximum pressure and temperature at which any reactor or pressure vessel can be used will depend upon the design of the vessel, its material of construction, and other components integral to its design. Since all materials lose strength at elevated temperatures, any pressure rating must be stated in terms of the temperature at which it applies. The listings shown in this catalog show the maximum allowable working pressure (MAWP) for each vessel in pounds per square inch (psi) and in bar at the maximum rated temperature for that particular design when that vessel is constructed of Type 316 Stainless Steel. Maximum pressure and temperature limits for vessels constructed of other alloys are computed and assigned by the Parr Engineering Department in accordance with all applicable regulations.

Lower operating temperatures sometimes permit higher working pressures. For example, the 4560HT High Temperature reactors are rated at 2000 psi (138 bar) maximum pressure and 500 °C maximum temperature. Standard 4560 reactors are rated at 3000 psi (200 bar) maximum pressure at 350 °C maximum temperature.

One should not assume that any vessel being operated at a lower temperature can be used at pressures exceeding the rated MAWP. Factors other than the material strength of the vessel wall may well be the constraint controlling the rating. Other factors that can limit the pressure and temperature ratings are the closures design, the magnetic drive, the type of seal, the choice of other components used, as well as the material of construction. The maximum operational temperature of some materials is much lower than what is permissible with stainless steel as shown in Table II. Users are encouraged to contact the Parr Customer Service Department with any questions.

**Multiple factors are involved in safely calculating the maximum working pressures and temperatures of Parr Reactors and Pressure Vessels. Please contact Parr Customer Service Department for more information and to assist you in making the correct purchase decision.**

Table II  
Maximum Allowable Temperatures

Materials of Construction	Maximum Temperature
T316/316L Stainless Steel	800 °C
Alloy 20	426 °C
Alloy 230	980 °C
Alloy 400	482 °C
Alloy 600	625 °C
Alloy 625 Gr 1	648 °C
Alloy A-286	371 °C
Alloy B-2/B-3	426 °C
Alloy C-276	625 °C
Nickel 200	315 °C
Titanium Grade 2, 3, 4, 7	315 °C
Zirconium Grade 702, 705	371 °C

**Maximum pressure and temperature ratings for vessels constructed of alloys other than T316SS will be computed and assigned by the Parr Engineering Department.**



# High Torque Magnetic Drives

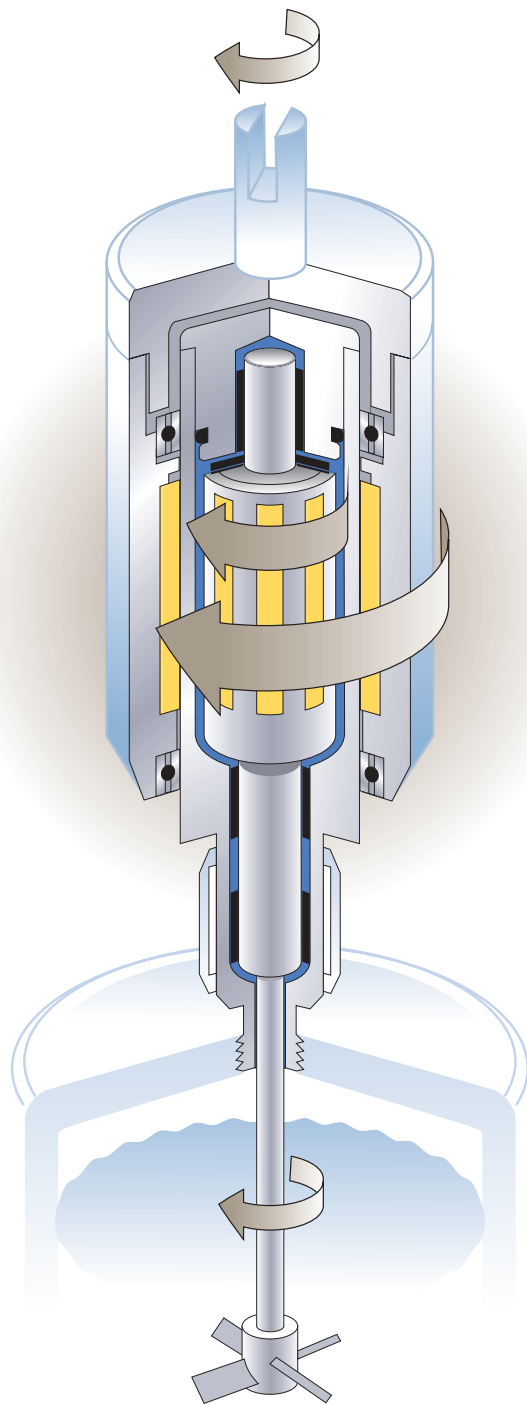

**All Parr stirred reactors are equipped with a magnetic drive** to provide a trouble-free linkage to an internal stirrer, thereby avoiding the leakage problems which can arise with a packed gland stirrer drive. With a Parr magnetic drive there are no rotating seals. The drive turns freely and the system remains gas-tight, permitting long, continuous runs at pressures up to 5000 psi (345 bar) with little or no attention to the seal and drive.

Parr drives are assembled with specially designed permanent magnets which have excellent temperature stability and can be depended upon to operate for long periods with little or no flux degradation. Magnets for the inner rotor to which the stirrer shaft is attached are enclosed in a stainless steel (or other alloy) housing, permanently sealed by welding and supported by

graphite-filled, PTFE bushings to provide a long life, chemically inert stirring system. Magnets for the outer drive are also fully enclosed and supported by twin, high quality sealed ball bearings for smooth operation and long life. A water cooling sleeve attached to each drive protects the components from excessive heat arising from the reactor.

## Four Sizes

Parr magnetic drives are made in four sizes (as shown in the chart on the facing page), designed to match the full range of Parr reactor sizes and to provide alternate drives for high viscosity loads, higher stirring speeds and other special requirements. Each drive is assembled in a sealed housing which threads directly into the reactor head.

**Parr uses neodymium-iron-boron magnets with 25% more coupling force than samarium-cobalt magnets. With very few exceptions involving gear reduction drives, the magnetic stirrers fitted to reactors have higher coupling torques than the stall conditions of standard motors. Today magnetic drives are used with confidence for high viscosity polymerization reactions.**

**Parr magnetic drives are supported with three graphite-filled PTFE bushings and quality internal ball bearings. They routinely deliver 2000 hours of operation without service.**





The General Purpose and Heavy Duty models are the standard units normally furnished with the reactor sizes listed in the adjoining table. The Extra Heavy Duty model is a special high torque drive intended primarily for heavy loads and high viscosity applications. When it is used to replace a standard drive, the standard motor and drive system may have to be modified to provide the higher torque which the Extra Heavy Duty drive is capable of transmitting.

The 5500 Series Compact Reactors have a smaller magnetic drive that is intended for low viscosity applications.

#### Two Styles Available

Parr offers a choice of two styles of magnetic drives. The first operates with small diameter stirrer shafts which require a lower support bracket or "foot" bearing to stabilize the stirrer shaft. These drives are intended for high speed stirring for applications involving liquid-liquid or gas-liquid mixing.

The second are footless magnetic drives and employ a larger diameter stirrer shaft

designed to operate without this lower support bracket or "foot" bearing. These drives were originally designed for digesting ores where the abrasive solids would get caught in the PTFE foot bearing and wear away the stirrer shaft. They are also recommended for slower-speed mixers such as the anchor, paddle, or spiral stirrers. It is also important to select the appropriate motor which can handle the increased drag associated with the larger diameter shafts.

#### Alternate Packed Gland Drive

For rare circumstances where a direct mechanical drive is preferable to a magnetically coupled system, Parr can furnish a self-sealing packed gland which will maintain a reliable seal on the stirrer shaft at working pressures up to 2000 psig (138 bar). These glands are made to a Parr design which uses a combination of cones and O-rings in conjunction with pressure from within the vessel to maintain a positive seal on the rotating shaft.

### Parr Magnetic Drive Series

Magnetic Drive	Coupling Torque (in-lb)*	Shaft Diameter (inches)	Foot Bushing Required? (see text above)	Ordering Guide Abbreviation	Supplied as Standard Mag Drive on Reactors with these Volumes:
General Purpose	16	3/16"	Yes	M	25 mL to 2 L
	16	3/8"	No (Footless)	FMD1	
Heavy Duty	60	3/8"	Yes	HD	1 to 5 Gallon
	60	5/8"	No (Footless)	FMD2	
Extra Heavy Duty	120	3/8"	Yes	XHD	1 to 5 Gallon
	120	5/8"	No (Footless)	FMD3	
Compact	2.5	3/16"	Yes	N/A	5500 Compact Reactor

\* in-lb = 0.11 Newton Meter

Please refer to the Parr Magnetic Drives Operating Manual (234M) at <https://www.parrinst.com/download/37494>

# Split-Ring Closures



Split-Ring with Compression Bolts for Moveable Vessels



Split-Ring with Captive Compression Ring and Bolts for Fixed Head Vessels



Split-Ring for Self-Sealing O-ring Closures

## Split-Ring

U.S. Patent No. 2625296

We have all heard the story of the man who resigned from the Patent Office around 1900 because he believed that everything that could be invented already had been. That is not the philosophy that has driven Parr Instrument Company over its more than a century of service to the chemical industry. The following prediction first appeared in February 1930 in the "Forward" of our bulletin describing our catalytic hydrogenation apparatus.

"The greatest chemical discoveries are yet to be made, untold numbers of which will result from the new studies in catalysis and catalytic reactors. These studies have already unearthed a mine of information, but with a more exact knowledge of catalytic processes, much more will be learned in the future."

We are delighted with the foresight of our predecessors here at Parr and are dedicated to continuing this outlook for the future as we conduct our second century of service to our friends and customers in this critical industry.

## Easy Access to Pressure Vessels

Parr reactors and pressure vessels are equipped with a unique split-ring cover clamp which adds greatly to the convenience of the equipment and the ease with which it can be handled. This is an exclusive Parr design (see sidebar) which allows easy access to a pressure vessel without using a heavy screw cap, cumbersome cover clamps, or a wide flange for moveable bolts. Instead, the head is clamped to the cylinder by either a Type 4140 steel or a Type 316 Stainless Steel ring which has been split into two sections. These sections slide into place from the sides without interfering with any fittings attached to the head.

## Self-Sealing and Compression Bolt Designs

For reactors and vessels in which a self-sealing O-ring is used as the main head seal, there are no compression bolts in the split-ring sections. The vessel is closed by simply sliding the two ring sections into place and locking them with either an encircling drop band or with attached, quick-opening latches. This convenient closure can be

used on most small and mid-sized stirred reactors and pressure vessels, provided the intended operating temperature does not exceed the allowable working temperature limit for the O-ring seal. Self-sealing O-rings are not recommended for low pressure applications. See [page 18](#) for additional information.

Split-ring closures for reactors with PTFE, flexible graphite, metal or other contained, flat gaskets have a set of compression bolts in the rings which must be tightened to develop the compressive force required to seal the gasket. These split-rings are locked together with either a drop band or quick opening latches.

With either style, the closure parts come completely away from the vessel so that the head with all of its fittings can be lifted from the cylinder or the cylinder can be dropped away without disrupting any attached fittings. When compression bolts are used, they are simply tightened or loosened, they are never completely removed from the split-ring or drop band. This saves time both in opening and closing the vessel and in looking for lost parts.

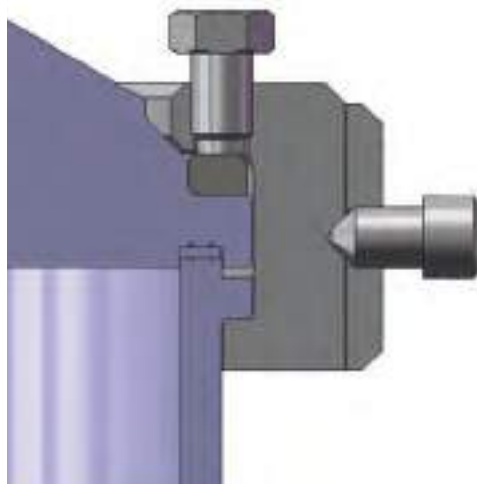

**Split-Ring with Compression Bolts and Drop Band**

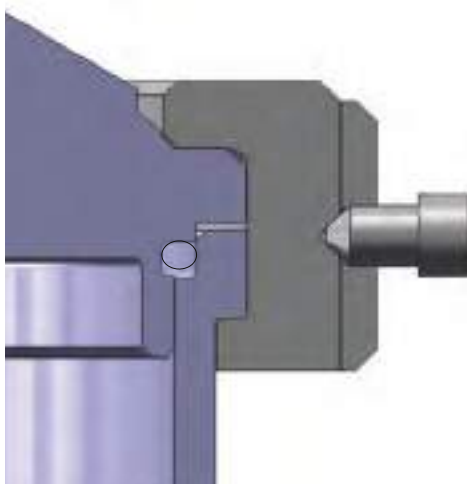

**Split-Ring with Drop Band and No Compression Bolts**

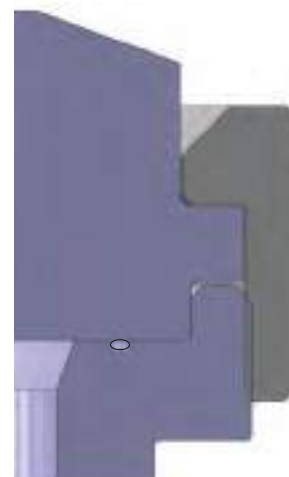

**Screw Cap Closure**

**Split-ring closures add many attractive features to Parr reactors and pressure vessels.**

- The reactor or vessel can be opened and closed without disturbing any connections or fittings attached to the head.
- The full inside diameter of the vessel is exposed when the head is removed.
- A maximum area is exposed on the head for attaching valves and fittings.
- There are no cumbersome bolt flanges or threaded studs to interfere with operations.
- No delicate threads on the cylinder to gall or to be damaged in handling.



**Split-Ring with Compression Bolts, Latches, and No Drop Band**

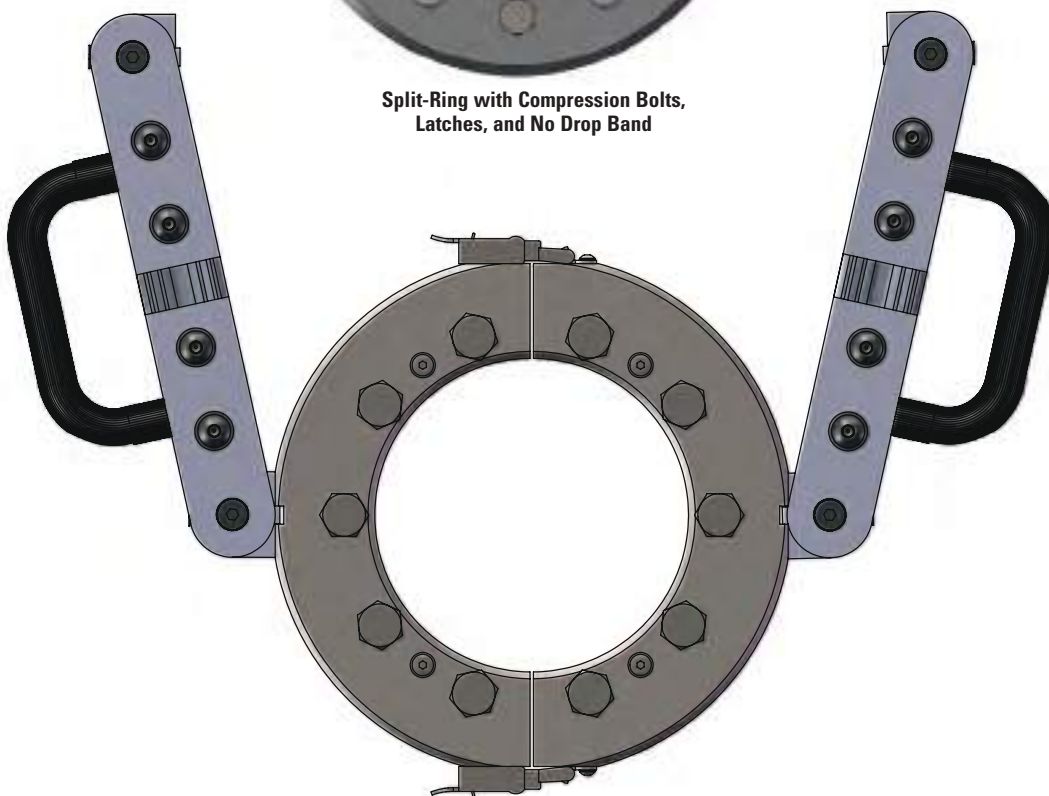

**Hinged Split-Rings**

**Screw Cap Closures**

Parr uses screw cap closures on small vessels where enough sealing force can be developed by simply tightening the main screw cap. This design can be made more compact than the split-ring closure and is used primarily on general purpose vessels with volumes of less than 100 mL.

# Gasket and Seals

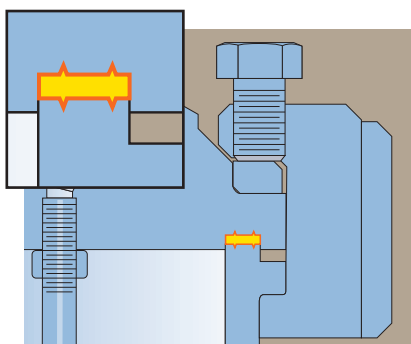

Flat PTFE Gasket

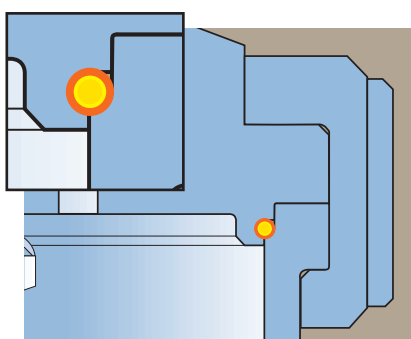

O-ring FKM Seal

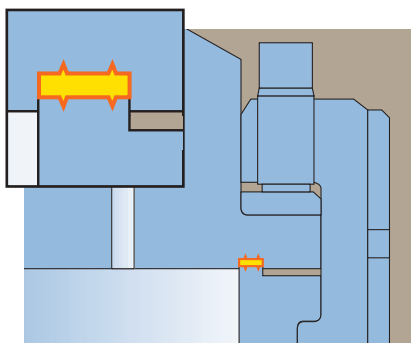

Flat Flexible Graphite Gasket

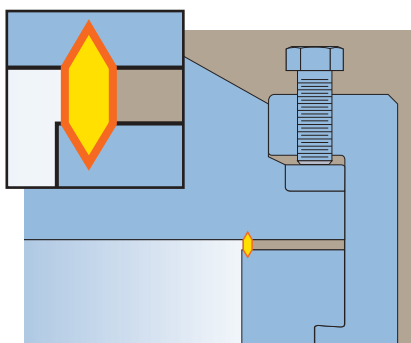

High Pressure Metal Gasket

There are four different types of gasket materials for the main head seal in Parr reactors and pressure vessels, each with its own advantages and limitations. Some of these are recent additions which have significantly expanded the choices a user can consider when selecting a closure and gasket material for the intended operating conditions.

## Confined and Contained Flat PTFE Gaskets for Temperatures to 350 °C

The traditional and most popular main head gasket for Parr vessels is a flat gasket made of a PTFE fluoropolymer. In Parr flat gasket closures, the gasket is held in a recess in the vessel cover. The mating lip on the cylinder closes the recess, leaving the gasket completely confined with only a small inside edge exposed to the reactants within the vessel. This combination of complete gasket containment and the exceptional properties of PTFE materials produces a reliable closure for working temperatures up to 350 °C.

Flat contained gaskets require an initial loading pressure in order to develop and to maintain a tight seal. In Parr designs this is produced by tightening a ring of compression bolts in a split-ring cover clamp. Fortunately PTFE is slightly “plastic” and will flow under pressure, producing a seal that improves with each use as the gasket is forced into the faces on the head and cylinder. It also is a very forgiving seal which does not require the special care needed to achieve a uniform loading, which is essential when working with a metal or other non-plastic gasket material.

An equally important advantage of the PTFE gaskets is their essentially universal chemical resistance.

## Self-Sealing O-rings

Parr has greatly expanded its offerings of reactors and vessels which feature self-sealing O-ring closures. In these designs the sealing force on the gasket is developed from pressure within the vessel itself, eliminating the need for compression bolts in the split-ring to pre-load the seal. In these self-sealing closures the split-ring sections simply lock the head and cylinder together.

***Operating reactors and vessels that incorporate a self-sealing O-ring at pressures less than ~20 percent of their maximum working pressure will need to be modified since diminished force is available to fully energize the seal.***

Users who select the self sealing O-ring design must consider two important characteristics of elastomeric materials. First, they will not withstand operating temperatures as high as the PTFE gaskets. Secondly, none of these materials offers the universal chemical resistance of PTFE polymers. The chemical resistance is especially important since the O-ring is directly exposed to the contents of the vessel.

Although there are a number of available O-ring materials, the real choice comes down to two. Fluoroelastomer (FKM) O-rings, such as Viton, are a first choice for Parr self-sealing closures. They have good chemical resistance and a working temperature up to 225 °C. Perfluoroelastomer (FFKM) O-rings, such as Kalrez®, have extremely broad chemical resistance and can be used at working temperatures up to 300 °C. Unfortunately, this material should probably be considered an “exotic” because it costs approximately 80 times



**O-ring Main Head Seal with Retaining Lip**

as much as an FKM O-ring. While it will raise the allowable working temperature to 300 °C, as a practical matter, most users intending to work at this temperature level would be well advised to choose a closure with a flat PTFE gasket and a 350 °C temperature limit. Other exotic O-ring materials are available, and there are economically priced materials such as ethylene-propylene that will resist some materials that cause FKM to fail, with only slight sacrifices in operating temperatures.

**Contained Flat Flexible Graphite Gaskets for Temperatures to 600 °C**

For operating temperatures above 350 °C, Parr uses a flexible form of graphite, called Grafoil®, which has proven to be an excellent high temperature sealing material. It consists of flexible layers of graphite bonded together to produce a gasket that is almost as easy to seal as a flat, PTFE gasket, but with an almost unlimited temperature range and excellent chemical resistance.

Parr has converted all of its standard designs to accept a flat, Grafoil gasket whenever operating temperatures above 350 °C are required, replacing the metal gaskets formerly used for high temperatures. These flexible graphite gaskets are held in grooves identical to the ones used for PTFE gaskets and sealed with the same split-ring closures. This makes it possible to substitute a PTFE gasket whenever the vessel is to be used at temperatures below 350 °C. Grafoil gaskets can be reusable, but their service life is shorter than can be obtained with a PTFE gasket.

**Metal Gaskets**

Metal gaskets have traditionally been the only gaskets available for use at temperatures above 350 °C. Parr has designs for diamond cross-section metal gaskets which can be furnished for special applications, but we would recommend the flexible graphite gaskets described above for most applications.

**Trademarks of Sealing Materials**

A number of gasket materials have so dominated their product categories that their Trade Names have become more common than the actual material designation itself. In an attempt to respect the value of these Trade Names and their proper usage and to minimize the disruptions in our descriptions, we have adopted the following generic material descriptions and designations for use in this catalog. Where available we have selected the ASTM material designation.

Common or Trade Name	Material	Designation
Viton®	fluoroelastomer	FKM
Kalrez®	perfluoroelastomer	FFKM
Teflon®	tetrafluoroethylene polymer	PTFE
Grafoil®	flexible graphite	FG

*Viton®, Kalrez®, Teflon® are Registered Trademarks of DuPont.  
Grafoil® is a Registered Trademark of UCAR Carbon Co. Inc.*

## Two Mounting Styles



Model 4523 Bench Top Reactor, 1 liter, Fixed Head

### Fixed Head Reactors

Parr offers most of its laboratory reactors in a fixed head design. This includes all reactors with volumes from 25 mL to 20 liters. In these reactors the head of the vessel may remain fixed in the reactor support stand. All attachments to the head: gas and liquid feed and discharge lines, cooling water, vapor take-off and condenser, thermocouple and any electrical leads can remain permanently in place. The reactor is opened by simply removing the split-ring and lowering the cylinder away from the head, leaving all of the attachments undisturbed. If desired the complete vessel assembly can be removed from the head support plate.

The support frames for fixed head reactors vary based on the sizes and weights of the vessels:

- For vessels with volumes of 25 mL to 600 mL, the cylinder may be lowered and removed manually by the operator
- Vessels with volumes of 1 to 2 liters include a manual lift mechanism to raise or lower the cylinder
- Vessels with volumes greater than two liters or where weight dictates include a pneumatic cylinder lift mechanism.



Close up view of a fixed head reactor with the vessel and heater lowered

### Moveable Vessel Reactors

As an alternate to the fixed head designs described on the previous page, all Parr reactors can be furnished in designs which allow the entire vessel to be removed as a complete assembly from the support stand allowing for charging, product recovery, and cleaning. In the smaller and mid-sized models the entire vessel is simply lifted out of the stand by hand. In the larger models, the vessel can be opened and closed with the cylinder remaining in the heater, but the head must be lifted off manually. In the largest (10 Liter and 20 Liter) models, a chain hoist is provided for lifting the heavier head and cylinder.

These moveable reactors will be attractive to users that intend to operate fairly simple batch systems rather than continuous flow arrangements, and that want to be able to remove the vessel for product recovery, charging or cleaning. They will also appeal to those that need to prepare the vessel in a special atmosphere, or want to clean the cylinder and stirrer at a site away from the reactor stand and heater. There is also the added advantage of being less expensive than the fixed head models since they do not require the more elaborate head or the cylinder and heater lift mechanism.



High Pressure Moveable Vessel, 600 mL,  
for use to 5000 psi



4544 Bench Top Reactor, 600 mL, Moveable Vessel, Split-Ring with Compression Bolts

# Parr Instrument Company Warranty

**Parr Instrument Company (Parr)** combustion bombs, calorimeters, reactors, pressure vessels and associated products are designed and manufactured only for use by or under the direct supervision of trained professionals in accordance with specifications and instructions for use supplied with the products. For that reason, Parr sells only to professional users or distributors to such users. Parr produces precision equipment and associated products which are not intended for general commercial use.

**Exclusive Warranty.** To the extent allowed by law, the express and limited warranties herein are the sole warranties. Any implied warranties are expressly excluded, including but not limited to implied warranties of merchantability or fitness for a particular purpose.

## Warranty Conditions:

- 1. Non-assignable.** The warranties herein extend only to the original purchaser/user and to the distributors to such users. These warranties or any action or claims based thereon are not assignable or transferable.
- 2. Use of product.** The warranties herein are applicable and enforceable only when the Parr product:
  - (a) Is installed and operated in strict accordance with the written instructions for its use provided by Parr.
  - (b) Is being used in a lawful manner.
  - (c) Has not been modified by any entity other than Parr Instrument Company.
  - (d) Has been stored or maintained in accordance with written instructions provided by Parr, or if none were provided, has been stored and maintained in a professionally reasonable manner.
- 3. The user's responsibility.** Parr engineers and sales personnel will gladly discuss available equipment and material options with prospective users, but the final responsibility for selecting a reactor, pressure vessel or combustion bomb which has the capacity, pressure rating, chemical compatibility, corrosion resistance and design features required to perform safely and to the user's satisfaction in any particular application or test must rest entirely with the user – not with Parr. It is also the user's responsibility to install the equipment in a safe operating environment and to train all operating personnel in appropriate safety, operational and maintenance procedures.
- 4. Warranty period.** Unless otherwise provided in writing by Parr, the warranties herein are applicable for a period of one year from date of delivery of the product to the original purchaser/user. Note, however, that there is no guarantee of a service life of one year after delivery.
- 5. Notification.** To enforce any express warranty created herein, the purchaser/user must notify Parr in writing within thirty (30) days of the date any defect is detected. Upon request of Parr, the part or product involved must be returned to Parr in the manner specified by Parr for analysis and non-destructive testing.

## Express Warranties.

**Subject to the above Conditions, Parr expressly warrants that its products:**

1. Are as described in the applicable Parr sales literature, or as specified in Parr shipping documents.
2. Will function as described in corresponding Parr sales bulletins or, for specially engineered assemblies, as stated in the sales proposal and purchase agreement.
3. Will remain free from defects in materials and workmanship for the Warranty Period.

## Limitations on the Parr Warranty.

**As to the original purchaser/user and to the distributors to such users,** Parr limits its liability for claims other than personal injury as follows:

1. Replacement or repair. With respect to express warranties herein, Parr's only obligation is to replace or repair any parts, assemblies or products not conforming to the warranties provided herein.
2. Disclaimer of consequential damages. In no event shall Parr be liable for consequential commercial damages, including but not limited to: damages for loss of use, damages for lost profits, and damages for resulting harm to property other than the Parr product and its component parts.

## Indemnity and Hold Harmless.

**Original purchaser/user agrees to indemnify and hold Parr harmless** for any personal injuries to original purchaser/user, its employees and all third parties where said injuries arise from misuse of Parr products or use not in accordance with specifications and instructions for use supplied with the Parr products.



# Stirred Reactor Systems **Chapter 2**



## **Inside this chapter you will find:**

[4520 Bench Top,  
1000 & 2000 mL](#)

[4520 HP Bench Top,  
970 & 1900 mL](#)

[4530 Moveable Cart or Floor Stand,  
1000 & 2000 mL](#)

[4530 HP Moveable Cart or Floor Stand,  
970 & 1900 mL](#)

[4540 HP Bench Top, Floor Stand, or Moveable Cart,  
600 & 1200 mL](#)

[4550 Moveable Cart or Floor Stand,  
1 & 2 Gallon \(3.75 & 7.99 L\)](#)

[4555 Floor Stand,  
2.6 & 5 Gallon \(10 & 18.75 L\)](#)

[4560 Mini, Bench Top,  
100-600 mL](#)

[4560 HT Mini, Bench Top,  
300-600 mL](#)

[4570 HP/HT, Bench Top, Moveable Cart, or Floor Stand,  
250-1800 mL](#)

[4580 HP/HT, Moveable Cart or Floor Stand,  
1 & 1.5 Gallon \(3.75 & 5.5 L\)](#)

[4590 Micro, Bench Top,  
25-100 mL](#)

[4590 HP Micro, Bench Top,  
25-100 mL](#)

[4590 HP/HT Micro, Bench Top,  
25-100 mL](#)

[5100 Low Pressure Glass or Metal, Bench Top,  
160-1500 mL](#)

[5500 Compact Bench Top,  
25-600 mL](#)

# Reactor Selection Guide



It is possible to convert most of these reactors from one size to another within the same series. This is done by substituting a longer or shorter cylinder with corresponding internal fittings including the stirrer shaft, thermowell or thermocouple, dip tube and cooling coil (if installed). In some cases, the heater will also need to be changed. The Parr Customer Service department will be happy to provide a list of the appropriate conversion parts for any contemplated conversion.



**The selection process starts with establishing the Four Basic Specifications discussed below.** Having set these requirements, the user can then identify a suitable series group from the Guide to

Parr Stirred Reactors. The user should then review the standard fittings. Finally, a list of Secondary Specifications should determine some of the finer details of the system.

## 1 Establish 4 Basic Specifications

### 1. Maximum Operating Pressure

Parr offers a number of operating pressures. Vessels 600 mL and under in volume are typically rated for 3000 psi, and vessels 1 L or larger are typically rated for 1900 psi. We also offer 5000 psi versions of models up to approximately 2 L, and 3000 psi versions of models up to 5.5 L. Some pressure limits can be increased with custom designs. However, higher pressure vessels generally require thicker walls, which can make temperature control more difficult, and larger volume, high pressure vessels are heavier and more difficult to handle. We also have a line of 5100 Series Low Pressure Reactors which can handle pressures up to 150 psi with a glass cylinder or up to 1000 psi with a metal cylinder.

### 2. Maximum Operating Temperature

Traditionally, the choices here have been up to 350 °C for vessels with PTFE gaskets and up to 500 °C for flexible graphite (previously metal) gaskets. Parr added the option of a self-sealing O-ring closure for general purpose vessels over a full range of volumes. These quick closing designs are limited to 225 °C, although this can be raised to 300 °C with special O-ring materials.

### 3. Vessel Size

Standard Parr stirred reactors are offered in many sizes ranging from 25 mL to 18.75 liters (5-gallon). It should be noted that these volumes refer to the free space in the vessel, and for safe operation the maximum liquid charge held in the vessel typically should not exceed two-thirds of the available free space in sealed batch operations. Generally, several vessel volumes are offered within most series, and reactor sizes can be reconfigured with conversion parts.

### 4. Material of Construction

Parr reactors are normally made of Type 316 Stainless Steel, but they can be made of other alloys as well.

The list of available materials of construction includes:

- Type 316/316L Stainless Steel
- Alloy A-286
- Alloy 20
- Alloy 230
- Alloy 400
- Alloy 600
- Alloy 625
- Alloy B-2/B-3
- Alloy C-276
- Nickel 200
- Titanium Grades 2, 3, 4, & 7
- Zirconium 702 & 705

### Other materials may be available upon request.

The majority of organic reactions can be handled in a standard T316 Stainless Steel vessel, but other corrosion resistant alloys are available to provide vessels suitable for use with a wide range of corrosive acids, bases, salts and gases. Special alloy construction can be provided for both the internal parts of the vessel and the external valves and fittings. However, there are considerable cost savings if the user can accept standard external parts made of stainless steel instead of a special alloy.

There is more detailed information on special materials in the "Materials of Construction" section of Chapter 1, starting on [page 10](#), of this catalog.

## Moveable and Fixed Head Designs



The moveable head is best when the user prefers to remove the entire reactor in one piece after running the operation.



The more flexible fixed head design allows the user to remove the cylinder and leave the head and all of its attachments mounted to the stand. It is also possible to remove the entire reactor in one piece.

## 2 Select Appropriate Series

Series No.	Reactor Type	Nominal Size	Maximum Pressure psi (bar)	Maximum Temperature °C
<a href="#">4520</a>	Bench Top	1000 and 2000 mL	1900 (131)	225-350
<a href="#">4520 HP</a>	High Pressure Bench Top	970 and 1900 mL	2900 (200)	350
<a href="#">4530</a>	Moveable Cart or Floor Stand	1000 and 2000 mL	1900 (131)	225-350
<a href="#">4530 HP</a>	High Pressure Moveable Cart or Floor Stand	970 and 1900 mL	2900 (200)	350
<a href="#">4540</a>	High Pressure Bench Top, Floor Stand or Cart	600 and 1200 mL	5000 (345)	350
<a href="#">4550</a>	Moveable Cart or Floor Stand	1 and 2 gallon (3.75 and 7.99 L)	1900 (131)	225-350
<a href="#">4555</a>	Floor Stand	5 and 2.6 gallon (18.75 and 10 L)	1900 (131)	225-350
<a href="#">4560</a>	Mini, Bench Top	100-600 mL	3000 (207)*	225-350
<a href="#">4560 HT</a>	High Temperature Mini, Bench Top	300-600 mL	2000 (138)	500
<a href="#">4571-4572</a> <a href="#">4577-4578</a>	High Pressure/High Temperature, Moveable Cart or Floor Stand	1000 and 1800 mL	5000 (345)	500
<a href="#">4575A-4576A</a> <a href="#">4575B-4576B</a>	High Pressure/High Temperature, Bench Top	250 and 500 mL	5000 (345)	500
<a href="#">4581-4584</a>	High Pressure/High Temperature, Moveable Cart or Floor Stand	1 and 1.5 gallon (3.75 L and 5.5 L)	3000 (207)*	500
<a href="#">4590</a>	Micro, Bench Top	25-100 mL	3000 (207)*	225-350
<a href="#">4590 HP</a>	High Pressure Micro, Bench Top	25-100 mL	5000 (345)	350
<a href="#">4590 HP/HT</a>	High Pressure Micro, Bench Top, High Temperature (Fixed Head Only)	25-100 mL	5000 (345)	500
<a href="#">5100</a>	Low Pressure Glass or Metal Reactors	160 mL-1.5 L	150 (10.3) Glass 1000 (69) Metal	225 225-300
<a href="#">5500</a>	Mini or Micro, Bench Top, Compact Stand	25-600 mL	3000 (207)*	225-350

\* 200 bar for CE orders

**Custom options available.** Contact Parr's Customer Service Department.

### Size

25 mL < > 18.75 L

Parr Instrument Company offers laboratory reactors and pressure vessels in sizes from 25 mL to 18.75 L. Generally it is best to select a size that will allow for 1/3 free space. This allows for some liquid expansion during the heating phase of a reaction.

### Pressures (psi)

1900 > 3000 > 5000

Maximum Allowable Working Pressures (MAWP) are determined by adherence to the ASME pressure vessel design criteria. There are three ranges; up to 1900 psi, up to 5000 psi, and in most cases reactors in the 25 mL to 600 mL range can be rated to 3000 psi. Parr Instrument Company recommends research be restricted to 90% of any vessel's MAWP rating because of the standard rupture disc installed. A vessel's pressure capacity is directly tied to the temperature the vessel will be operating.

### Temperatures

225 °C < > 500 °C

Operating Temperatures have traditionally been limited to 350 °C using a flat PTFE gasket. Flexible graphite gaskets have now extended the range to 500 °C. New quick opening designs have been added to the Parr product line that use O-rings for the seal and normally limit the temperature to 225 °C (Viton®) or 300 °C (Kalrez®).

# Reactor Selection Guide

## 3 Confirm Standard Fittings

**Pressure Gage**, analog type, which shows the pressure within the vessel at all times.

**Liquid Sampling Valve** for withdrawing liquid samples through the dip tube shared with the gas inlet valve. Incoming gas can be used to clear the dip tube between liquid samples.

**Thermocouple or Thermowell** for measuring the temperature within the vessel. In small reactors, a thermocouple encased in a metal sheath extends directly into the vessel. In larger reactors, and in vessels constructed of special alloys, the control thermocouple is inserted into a thermowell which extends to a point near the bottom of the vessel.

**Gas Release Valve** to release gas from the reactor during or at the completion of a run.

**Internal Stirring System** consists of a motor drive magnetically coupled to an internal stirrer shaft with attached turbine-type impeller(s).

**Dip Tube**

**Cooling Coil**

**Safety Rupture Disc** to protect the vessel and the operator from dangerous pressures beyond the rated limit for the vessel.

**Gas Inlet Valve** for charging gas into the reactor. This valve and the liquid sampling valve are connected to a dip tube which extends to the bottom of the vessel.

**Guide or Foot Bearing** with a PTFE bushing to support and stabilize lower stirrer shaft. (Not required with footless magnetic drive)

## 4 Specify Detailed Options

**There are a number of options to be considered and selections to be made in order to complete the specifications for a reactor.** You will need to choose from the following:

### 1. Sealing Style

Parr reactors may be provided with a flat gasket seal or an O-ring seal. Most commonly, a flat PTFE gasket is used. These are generally good for temperatures up to 350 °C. A graphite seal for temperatures up to 500 °C is used for high temperature systems.

O-ring seals allow for a convenient, boltless closure, but the material must be checked carefully against the intended process as there are many solvents and gases which attack O-rings.

Our typical O-ring seal is designed to be self-sealing at high pressures. However, this design needs to be modified when the reactor is going to be operated at or below 20% of its high pressure rating.

### 2. Mounting Style

Parr reactors may be provided with a moveable vessel mounting or fixed head mounting.

In the moveable vessel style the complete vessel assembly (only the head in the one gallon or larger) is removed from the heater for charging, product recovery, and vessel cleaning.

In the fixed head style the head remains in the mounting fixture and the reactor heater, then the cylinder drops away to cool and open the vessel. This is useful for users who wish to leave inlet and feed lines, discharge and vent lines, condensers, and similar head connections undisturbed between runs. The head is easily removable by sliding the head out of its slot on the stand.

### 3. Support Stand

Parr stirred reactors are most commonly mounted on a bench top stand for sizes of 2 liter or smaller. Vessels 1 liter or larger may be mounted on either moveable carts or fixed floor stands. Care should be taken to check stand dimensions with the available space at the user's facility.

### 4. Stirrer Type

Parr reactors have a magnetic drive equipped for most low viscosity fluids and light slurries. Drives with higher coupling torque and more powerful motors are available for higher viscosity applications.

Also, many reactors require a lower support bracket to stabilize the stirring shaft. In applications with abrasive particles or heavy mixing, a "footless" magnetic drive with a larger diameter shaft may be provided.

**5. Cooling Coil**

An internal cooling coil can be installed in all reactors (except the Micro sizes) to remove the heat during a reaction and/or to cool the vessel at the end of a run. In some reactors a cooling coil is furnished as a standard fitting. In others, a coil can be added as an option in either serpentine style or alternately in a spiral style for selected models. For the micro sizes, with their limited dimensions, a cold finger may be added as an option.

**6. Gage and Rupture Disc Ranges**

The pressure gage range must be selected to provide the resolution desired, while having a range high enough to handle the maximum pressure the reactor will experience. One would be tempted to simply get a gage with the largest range possible, but this can reduce the resolution to unacceptable levels. One good rule of thumb for good resolution is to operate with the gage at half of its maximum range. The rupture disc is most commonly matched to the Maximum Allowable Working Pressure of the vessel, ensuring the disc will burst before reaching a pressure beyond the MAWP range. Care must be taken not to take the vessel above 90% of its burst pressure under normal operation. This will help protect the disc from the effects of repeated pressure cycles.

The rupture disc is most commonly matched to the Maximum Allowable Working Pressure of the vessel, ensuring the disc will burst before reaching a pressure beyond the MAWP range. Care must be taken not to take the vessel above 90% of its burst pressure under normal operation. This will help protect the disc from the effects of repeated pressure cycles.

**7. Controller Options**

Parr controllers are typically set up to control temperature, but may also be set up with digital displays of pressure, stirring speed, secondary temperature, and other displays and controls.

These may be set up with data logging via PC as well. For more information on these options, see the "[Reactor Controllers Section](#)" of this catalog.

**8. Certification**

ASME, CE, and PARR Certifications are available for users who require these recognized quality assurance certifications.

**9. Custom Options**

A wide range of custom options such as special openings in the head or cylinder, high viscosity stirrers, windows, special valves, heaters or jackets, explosion proof wiring, and volume modifications are available.

Various accessories, such as glass or PTFE liners, condensers, catalyst holders, and alternate stirrers are available to further adapt these reactors to the individual user's applications.

Detailed information for these and other options are found in Optional Accessories, [Chapter 7](#), starting on page 115 of this catalog.

**How to use the Ordering Guide:**

The last page of each Reactor Series in this chapter is an **Ordering Guide**. A composite identification/order number can be generated by combining the individual symbols from the separate sections. Omit any symbols not desired for the system.

**Example:** Using the Ordering Guide from the Series 4520 Stirred Reactors we have chosen to order a 1000 mL fixed head reactor, PTFE Flat Gasket, the vessel manufactured out of T316 Stainless Steel, a general purpose magnetic drive made of T316 Stainless Steel, 115V power supply, 1/4 hp explosion-proof motor, 3000 psi pressure gage, no bottom drain valve, and a 4848 controller.

The order number for that particular configuration would appear as follows:



**No. 4523-T-SS-M-SS-115-XP.25-3000-4848**

A.	C.	D.	E.	F.	G.	H.	I.	L.
Model	Gasket	Material	Stirrer	Drive MOC	Voltage	Motor	Gage	Controller
No. 4523	-T	-SS	-M	-SS	-115	-XP.25	-3000	-4848

Series Number:

# 4520

Type:  
**General Purpose**

Stand:  
**Bench Top**

Mounting Style:  
**Moveable or  
Fixed Head**

Vessel Sizes, mL:  
**1000-2000  
970-1900 HP**

Standard Pressure  
MAWP Rating, psi (bar):  
**1900 (131)**

Standard Maximum  
Operating Temp., °C:  
**225 w/ FKM O-ring  
300 w/ FFKM O-ring  
350 w/ PTFE Flat Gasket**

High Pressure (HP)  
MAWP Rating, psi (bar):  
**2900 (200)**

Maximum Operating  
Temperature, °C, at  
High Pressure (HP):  
**350 @ 2900 psi**

## Series 4520 Bench Top Reactors, 1 & 2 L

**These are the largest of the Parr Reactors that can be handled on a bench top.**

These reactors are available with an FKM O-ring seal for operating temperatures to 225 °C, and FFKM O-ring for temperatures to 300 °C, or with a flat, PTFE gasket for operating temperatures up to 350 °C maximum.

An optional HP (High Pressure) flat gasket version has been added for maximum allowable working pressure of 2900 psi (200 bar) at 350 °C. Both fixed head and moveable vessel designs are available. An optional pneumatic lift is available for the heavier 2 liter cylinder and heater. It should be noted, however, that the 2 liter, fixed head model is tall and may not be convenient to operate on a standard height bench top. We recommend using a floor stand. (See Series 4530)

With their 4-inch internal diameter, these mid-size reactors have sufficient space for special modifications, such as an internal cooling coil, bottom drain valve (not on 2 liter bench top), ball valve for a solids

charging port, catalyst addition devices, condensers, electrical feed-throughs and more. Details are provided in Chapter 7 of this catalog, starting on [page 115](#).

The standard magnetic stirrer drive on these 4520 Models works well for reaction mixtures

with viscosities up to 25,000 centipoise. For heavier stirring loads, these reactors can be equipped with larger magnetic drives, more powerful motors, and drive trains capable of delivering additional stirring torque.



**Model 4523 Bench Top Reactor, 1000 mL, Fixed Head, open to show Internal Fittings, and a 4848 Controller shown with optional Expansion Modules.**

## 4520

Series 4520 Pressure Reactor System Specifications				
Shaded bar indicates specifications that change within series.				
Model Number	4523	4524	4525	4526
Approximate Volume, mL	1000	2000	1000	2000
Approximate Volume for HP Models, mL	970	1900	970	1900
Maximum Pressure (MAWP)	1900 psi (131 bar)			
HP Maximum Pressure (MAWP)	2900 psi (200 bar)			
<b>Maximum Temperature</b>				
with FKM O-ring	225 °C			
with FFKM O-ring	300 °C			
with PTFE Flat Gasket	350 °C			
<b>Reactor Details</b>				
Mounting Style	Fixed Head		Moveable	
Stand Type	Bench Top			
Closure	Split-Ring (6 Compression Bolts for Flat Gasket, no Compression Bolts for O-ring)			
High Pressure Closure	Split-Ring (12 Compression Bolts for Flat Gasket, no Compression Bolts for O-ring)			
Valve Connections	1/8" Male NPT			
Magnetic Stirrer, Model No.	A1120HC6 General Purpose or A2140HC Footless			
Maximum Torque	16 Inch-Pounds			
Impeller(s), 6 blades	2 (2.28" dia. / HP: 2.00" dia.)			
Stirrer Motor	1/8 hp variable speed			
Pressure Gage, Size	4.5 inches			
Range	0-2000 psi (138 bar) / HP: 0-3000 psi (207 bar)			
Temperature Measurement	Thermowell			
Cooling Coil (optional)	Serpentine			
Bottom Drain Valve (BDV) (optional)				
Standard Pressure (1900 psi)	3/8" NPT	N/A	3/8" NPT	N/A
High Pressure (2900 psi)	1/4" NPT		1/4" NPT	
Lift Mechanism (optional)	Pneumatic		N/A	
<b>Heater Style</b>	Calrod			
Heater Power, Watts	1000 / 1500	1500 / 2000	1000 / 1500	1500 / 2000
<b>Electrical Supply</b>				
Volts, AC	115 / 230			
Maximum Load, amps, 115 / 230	12 / 9			
<b>Cylinder Dimensions</b>				
I.D. x Depth, inches	4.0 x 5.4	4.0 x 10.5	4.0 x 5.4	4.0 x 10.5
I.D. x Depth, inches for HP	3.75 x 5.4	3.75 x 10.5	3.75 x 5.4	3.75 x 10.5
Vessel Assembly Weight, pounds	33	38	30	36
Vessel Assembly Weight for HP, pounds	36	44	35	43
Cylinder Weight, pounds	8.9	13.7	8.9	13.7
Cylinder Weight for HP, pounds	11.3	18.4	11.3	18.4
<b>Reactor Dimensions</b>				
Width x Depth w/o Controller, inches	17 x 24			
Height, inches	38 (48 with BDV)	48	38 (48 with BDV)	48
Weight, pounds	105	120	100	115
<b>Spare Parts Kit</b>	4529M			
Other options available. See Ordering Guide, visit <a href="http://www.parrinst.com">www.parrinst.com</a> , or call for more information. Weights and dimensions are estimated from the base model. Final weights and dimensions will vary based on options selected.				

Series Number:

# 4520

## Series 4520 Bench Top Reactors, 1 & 2 L

### Index to Options

Option	Page
Certification	8
Materials of Construction	10
Magnetic Drive	14
Gaskets & Seals	18
Stirrer Motor	118
Rupture Disc	124
Pressure Gage	125
Cooling Coil	129
Bottom Drain Valve	131
4848 Reactor Controller	102
4871 Process Controller	109
A2110E Motor Controller	114

Custom Option	Page
Stirrers	120
Heaters	116
External Valves & Fittings	138
Solids Charging Ports	128
Condensers	123
Electrical Glands	137
Catalyst Addition Device	128
Catalyst Baskets	122
Relief Valves	125
Windows	136
Gear Drives	119
Explosion Proof Options	134
Liquid Sampling	130

Accessories	Page
Liners	129
Spare Parts Kits	137
Pressure Hoses	133
Check Valves	125
Liquid Pipettes	127
Gas Burettes	126



Model 4523 Bench Top Reactor,  
1000 mL, Fixed Head



Model 4526 Bench Top Reactor, 2000 mL, Moveable Head, and a 4848 Controller shown with optional Expansion Modules.



# Series 4520 Ordering Guide

The Order No. for the Base System is: **452\_\_-T-SS-M-115-VS.12-2000-4848**

A composite identification number to be used when ordering a 4520 Series Reactor can be developed by combining individual symbols from the separate sections below. For more information on how to use this ordering guide, [please see page 27](#).

A Base Model		
Model No.	Size	Vessel Style
4523	1000 mL	Fixed
4524	2000 mL	Fixed
4525	1000 mL	Moveable
4526	2000 mL	Moveable

High Pressure sizes are 970 mL & 1900 mL

B High Pressure Option	
-No Symbol	Standard Configuration (1900 psi / 131 bar)
-HP	2900 psi (200 bar)

C Gasket / Maximum Temperature	
-OV	FKM O-ring, 225 °C
-OK	FFKM O-ring, 300 °C
-T	PTFE Flat Gasket, 350 °C

D Vessel Material of Construction	
-SS	T316 Stainless Steel
-M0	Alloy 400
-IN	Alloy 600
-HB	Alloy B-2 / B-3
-HC	Alloy C-276
-CS	Alloy 20
-Ti2	Titanium Grade 2
-Ti4	Titanium Grade 4
-ZR702	Zirconium Grade 702
-ZR705	Zirconium Grade 705

See [page 10](#) or [24](#) for complete list of available alloys.

E Magnetic Stirrer Drive	
-M	General Purpose, 16 in-lb
-HD	Heavy Duty, 60 in-lb
-FMD1	Footless, General Purpose, 16 in-lb
-FMD2	Footless, Heavy Duty, 60 in-lb

F Mag. Drive Material of Construction	
-MOC Symbol	Indicate Material of Construction

G Electrical Supply	
-115	115 VAC
-230	230 VAC

H Motor Option	
-VS .12	Variable Speed, 1/8 hp
-VS .25	Variable Speed, 1/4 hp
-VS .50*	Variable Speed, 1/2 hp (230V only)
-XP .25	Explosion Proof, Variable Speed, 1/4 hp
-XP .50*	Explosion Proof, Variable Speed, 1/2 hp (230V only)
-AM .25	Air Motor, 1/4 hp
-AM .50	Air Motor, 1/2 hp

\* For use with Heavy Duty Magnetic Stirrer

I Pressure Gage	
-3000	3000 psi / 207 bar
-2000	2000 psi / 138 bar
-1000	1000 psi / 69 bar
-600	600 psi / 40 bar
-200	200 psi / 14 bar
-100	100 psi / 7 bar

J Internal Cooling Coil	
-SC	Serpentine Coil

K Bottom Drain Valve	
-BDV	Bottom Drain Valve, 3/8" NPT for standard systems, 1/4" NPT for HP systems (4523 & 4525 only)

L Controller	
-4848 (included in base system)	PID Control, Ramp & Soak Programming, Motor Speed Control, and Data logging with Software. (RS-485 to USB cable not included) For use with up to three additional display modules.
-4848B	Same as above but for use with up to six additional display modules.
-A2110E	Motor Controller
-4871	Process Controller (for enhanced control options)

See [Chapter 6](#) for a complete list of controllers and options.

M 4848 Controller Options	
-TDM	Tachometer Display Module
-MCM	Motor Control Module w/Tachometer
-PDM	Pressure Display Module
-HTM	High Temperature Cut Off Module
-ETLM	External Temperature Limit Module
-MTM	Motor Torque Module ( <i>must be installed with the MCM</i> )
-SVM	Solenoid Valve Module (for cooling control)
-A1925E4	RS-485 to USB Cable for 4848 Controller (required for data logging)
-A1925E6	RS-485 to USB Converter, isolated, 30-ft
-A2208E	RS-485 Daisy Chain for Multiple Controllers (Must be used with 1925E6)
-A3504HC	SpecView Software Package for 4838/4848 Controller

N Custom Options (List All Desired)	
-AS	Anchor Stirrer
-PS	Paddle Stirrer
-SA	Spiral Stirrer
-GE	Gas Entrainment Stirrer
-BF	Removable Baffle Set
-SB	Static Catalyst Basket
-DB	Dynamic Catalyst Basket
-CAD	Internal Catalyst Addition Device
-XCAD	External Catalyst Addition Device
-SCP	Solids Charging Port (Ball Valve)
-RC	Reflux Condenser
-RTC	Reflux/Take-Off Condenser
-WJ	Welded Jacket
-ABH	Aluminum Block Heater with Cooling Channels
-PL	Pneumatic Lift

See [Chapter 7](#) for a complete list of optional accessories.

O Certifications	
-ASME	ASME Documentation
-CE	CE Documentation
-P	Parr Certification

P Spare Parts Kit	
-4529M	Spare Parts Kit for 4520 Series

Please note that all options and combinations are not compatible with all models.

Series Number:

# 4530

Type:  
**General Purpose**

Stand:  
**Floor Stand or Cart**

Mounting Style:  
**Moveable or  
Fixed Head**

Vessel Sizes, mL:  
**1000-2000 Standard  
970-1900 HP**

Standard Pressure  
MAWP Rating, psi (bar):  
**1900 (131)**

Standard Maximum  
Operating Temp., °C:  
**225 w/ FKM O-ring  
300 w/ FFKM O-ring  
350 w/ PTFE Flat Gasket**

High Pressure (HP)  
MAWP Rating, psi (bar):  
**2900 (200)**

Maximum Operating  
Temperature, °C, at  
High Pressure (HP):  
**350 @ 2900 psi**

## Series 4530 Floor Stand Reactors, 1 & 2 L

**Series 4530 1 & 2 L Floor Stand Reactors can be moved, modified to fit your needs, and configured for polymer studies.** They are also available in high pressure versions.

- **Reactors configured for high torque applications.** The reactors in this series are mounted on a sturdy floor stand which will accommodate larger stirrer drive motors and stronger power trains that are generally not available for the bench top models. With these options it is possible to provide the high torque and low stirring speeds required for work with polymers, slurries, and other mixtures with viscosity of 1 million centipoise and more. These mountings are also better suited for the installation of a drain valve in the cylinder bottom for convenient removal of the reaction mixture while it is still hot.
- **Reactors requiring extensive modifications.** Floor stand mountings provide a good base for reactor modifications and for the addition of accessories, such as: condensers, packed columns, special motors, custom heaters, jacketed vessels, automatic valves or regulators, and many other fittings. Both fixed head and moveable vessel designs are available. An optional pneumatic lift is available for fixed head models
- **Reactors that need to be moved.** These reactors are designed for use in an area where a bench top is not available. Users who wish to move the reactor to storage when not in use, will appreciate the moveable cart design of the Series 4531 and 4532. These reactors are available with an FKM O-ring seal for operating temperatures to 225 °C, and FFKM O-ring for temperatures to 300 °C, or with a flat, PTFE gasket for operating temperatures up to 350 °C maximum.
- **HP versions.** These reactors are also available in a HP (High Pressure) version up to 2900 psi (200 bar) at 350 °C.

**4534 Floor Stand Reactor, 2000 mL, Fixed Head, with Heavy-Duty Footless Mag Drive, Serpentine Cooling Coil, optional Solids Charging Device, Cylinder equipped with Welded Jacket, and Bottom Drain Valve.**



## 4530

Series 4530 Pressure Reactor System Specifications						
Shaded bar indicates specifications that change within series.						
Model Number	4531	4532	4533	4534	4535	4536
Approximate Volume, mL	1000	2000	1000	2000	1000	2000
Approximate Volume for HP Models, mL	970	1900	970	1900	970	1900
Maximum Pressure (MAWP)	1900 psi (131 bar)					
Maximum Pressure for HP (MAWP)	2900 psi (200 bar)					
<b>Maximum Temperature</b>						
with FKM O-ring	225 °C					
with FFKM O-ring	300 °C					
with PTFE Flat Gasket	350 °C					
<b>Reactor Details</b>						
Mounting Style	Moveable		Fixed Head		Moveable	
Stand Type	Moveable Cart		Floor Stand		Floor Stand	
Closure	Split-Ring (6 Compression Bolts for Flat Gasket, No Compression Bolts for O-ring)					
High Pressure Closure	Split-Ring (12 Compression Bolts for Flat Gasket, No Compression Bolts for O-ring)					
Valve Connections	1/8" Male NPT					
Magnetic Stirrer, Model No.	A1120HC General Purpose or A2140HC Footless					
Maximum Torque	16 Inch-Pounds					
Impeller(s), 6-Blade	2 (2.28" dia. / HP: 2.00" dia.)					
Stirrer Motor	1/4 hp Variable Speed					
Pressure Gage, Size	4.5 inches					
Range	Standard: 0-2000 psi (138 bar) / HP: 0-3000 psi (207 bar)					
Temperature Measurement	Thermowell					
Cooling Coil (optional)	Serpentine					
Bottom Drain Valve (BDV) (optional)						
Standard Pressure (1900 psi)	3/8" NPT					
High Pressure (2900 psi)	1/4" NPT					
Lift Mechanism (optional)	N/A		Pneumatic Lift		N/A	
<b>Heater Style</b>						
Calrod						
Heater Power, Watts	1300		1000 / 1500	1500 / 2000	1000 / 1500	1500 / 2000
<b>Electrical Supply</b>						
Volts, AC	115 / 230					
Maximum Load, amps, 115 / 230	12 / 9					
<b>Cylinder Dimensions</b>						
I.D. x Depth, inches	4.0 x 5.4	4.0 x 10.5	4.0 x 5.4	4.0 x 10.5	4.0 x 5.4	4.0 x 10.5
I.D. x Depth, inches for HP	3.75 x 5.4	3.75 x 10.5	3.75 x 5.4	3.75 x 10.5	3.75 x 5.4	3.75 x 10.5
Vessel Assembly Weight, pounds	30	35	33	38	301	36
Vessel Assembly Weight for HP, pounds	35	43	36	44	35	43
Cylinder Weight, pounds	8.9	13.7	8.9	13.7	8.9	13.7
Cylinder Weight for HP, pounds	11.3	18.4	11.3	18.4	11.3	18.4
<b>Reactor/Stand Dimensions</b>						
Width x Depth w/o Controller, inches	35 x 18		21 x 28		21 x 28	
Height, inches	50		63		63	
Weight, pounds	200	215	225	240	225	240
Spare Parts Kit	4539M (General Purpose)					
Other options available. See Ordering Guide, visit <a href="http://www.parrinst.com">www.parrinst.com</a> , or call for more information. Weights and dimensions are estimated from the base model. Final weights and dimensions will vary based on options selected.						

## Series 4530 Floor Stand Reactors, 1 &amp; 2 L

## Index to Options

Option	Page
Certification	8
Materials of Construction	10
Magnetic Drive	14
Gaskets & Seals	18
Stirrer Motor	118
Rupture Disc	124
Pressure Gage	125
Cooling Coil	129
Bottom Drain Valve	131
4848 Reactor Controller	102
4871 Process Controller	109
A2110E Motor Controller	114

## Custom Option Page

Stirrers	120
Heaters	116
External Valves & Fittings	138
Solids Charging Ports	128
Condensers	123
Electrical Glands	137
Catalyst Addition Device	128
Catalyst Baskets	122
Relief Valves	125
Windows	136
Gear Drives	119
Explosion Proof Options	134
Liquid Sampling	130

## Accessories Page

Liners	129
Spare Parts Kits	137
Pressure Hoses	133
Check Valves	125
Liquid Pipettes	127
Gas Burettes	126



4532 Moveable Head on Moveable Cart, 2000 mL, and a 4848 Temperature Controller with optional Expansion Modules.



2000 mL Moveable Vessel



4533 Floor Stand Reactor, 1000 mL, Fixed Head Vessel with Gear Drive, Dual Condenser, Spiral Stirrer, and Bottom Drain Valve.

# Series 4530 Ordering Guide

The Order No. for the Base System is: **453\_\_-T-SS-M-115-VS.25-2000-4848**

A composite identification number to be used when ordering a 4530 Series Reactor can be developed by combining individual symbols from the separate sections below. For more information on how to use this ordering guide, [please see page 27](#).

A Base Model		
Model No.	Size	Vessel Style
4531	1000 mL	Moveable Head, Moveable Cart
4532	2000 mL	Moveable Head, Moveable Cart
4533	1000 mL	Fixed Head, Stationary Floor Stand
4534	2000 mL	Fixed Head, Stationary Floor Stand
4535	1000 mL	Moveable Head, Stationary Floor Stand
4536	2000 mL	Moveable Head, Stationary Floor Stand

High Pressure sizes are 970 mL and 1900 mL respectively.

B High Pressure Option	
-No Symbol	Standard Configuration (1900 psi / 131 bar)
-HP	2900 psi (200 bar)

C Gasket / Maximum Temperature	
-OV	FKM O-ring, 225 °C
-OK	FFKM O-ring, 300 °C
-T	PTFE Flat Gasket, 350 °C

D Material of Construction	
-SS	T316 Stainless Steel
-MO	Alloy 400
-IN	Alloy 600
-HB	Alloy B-2 / B-3
-HC	Alloy C-276
-CS	Alloy 20
-Ti2	Titanium Grade 2
-Ti4	Titanium Grade 4
-ZR702	Zirconium Grade 702
-ZR705	Zirconium Grade 705

See [page 10](#) or [24](#) for complete list of available alloys.

E Magnetic Stirrer Drive	
-M	General Purpose, 16 in-lb
-HD	Heavy Duty, 60 in-lb
-XHD	Extra Heavy Duty, 120 in-lb
-FMD1	Footless, General Purpose, 16 in-lb
-FMD2	Footless, Heavy Duty, 60 in-lb
-FMD3	Footless, Extra Heavy Duty, 120 in-lb

F Mag. Drive Material of Construction	
-MOC Symbol	Indicate Material of Construction

G Electrical Supply	
-115	115 VAC
-230	230 VAC

H Motor Option	
-VS .12	Variable Speed, 1/8 hp
-VS .25	Variable Speed, 1/4 hp
-VS .50	Variable Speed, 1/2 hp (230V Only)
-XP .25	Explosion Proof, Variable Speed, 1/4 hp
-XP .50	Explosion Proof, Var. Speed, 1/2 hp (230V Only)
-AM .25	Air Motor, 1/4 hp
-AM .50	Air Motor, 1/2 hp
-GDD	Geared Direct Drive (Fixed Head Only)

I Geared Direct Drive Ratio*		J Pressure Gage	
-3D	3:1, 0-600 rpm	-3000	3000 psi / 207 bar
-5D	5:1, 0-360 rpm	-2000	2000 psi / 138 bar
-10D	10:1, 0-180 rpm	-1000	1000 psi / 69 bar
		-600	600 psi / 40 bar
		-200	200 psi / 14 bar
		-100	100 psi / 7 bar

\* For -GDD Motor Option Only.

K Internal Cooling Coil	
-SC	Serpentine Coil

L Bottom Drain Valve	
-BDV	Bottom Drain Valve, 3/8" NPT for standard systems, 1/4" NPT for HP systems (1000 / 970 mL only)

M Controller	
-4848 (included in base system)	PID Control, Ramp & Soak Programming, Motor Speed Control, and Data logging with Software. (RS-485 to USB cable not included) For use with up to three additional display modules.
-4848B	Same as above but for use with up to six additional display modules.
-A2110E	Motor Controller
-4871	Process Controller (for enhanced control options)

See [Chapter 6](#) for a complete list of controllers and options.

N 4848 Controller Options	
-TDM	Tachometer Display Module
-MCM	Motor Control Module w/Tachometer
-PDM	Pressure Display Module
-HTM	High Temperature Cut Off Module
-ETLM	External Temperature Limit Module
-MTM*	Motor Torque Module
-SVM	Solenoid Valve Module (for cooling control)
-A1925E4	RS-485 to USB Cable for 4848 Controller (required for data logging)
-A1925E6	RS-485 to USB Converter, isolated, 30-ft
-A2208E	RS-485 Daisy Chain for Multiple Controller (must be used with A1925E6)
-A3504HC	SpecView Software Package for 4838/4848

\* The MTM must be installed in conjunction with the MCM.

O Custom Options (List All Desired)	
-AS	Anchor Stirrer
-PS	Paddle Stirrer
-SA	Spiral Stirrer
-GE	Gas Entrainment Stirrer
-BF	Removable Baffle Set
-SB	Static Catalyst Basket
-DB	Dynamic Catalyst Basket
-CAD	Internal Catalyst Addition Device
-XCAD	External Catalyst Addition Device
-SCP	Solids Charging Port (Ball Valve)
-RC	Reflux Condenser
-RTC	Reflux/Take-Off Condenser
-WJ	Welded Jacket
-ABH	Aluminum Block Heater with Cooling Channels
-PL	Pneumatic Lift

See [Chapter 7](#) for a complete list of optional accessories.

P Certifications	
-ASME	ASME Documentation
-CE	CE Documentation
-P	Parr Certification

Q Spare Parts Kit	
-4539M	Spare Parts Kit for 4530 Series

Please note that all options and combinations are not compatible with all models.

Series Number:

# 4540

Type:  
**High Pressure**

Stand:  
**Bench Top, Floor  
Stand, or Cart**

Mounting Style:  
**Moveable or  
Fixed Head**

Vessel Sizes, mL:  
**600 and 1200**

High Pressure  
MAWP Rating, psi (bar):  
**5000 (345)**

Standard Maximum  
Operating Temperature, °C:  
**350 w/ PTFE Flat Gasket**

## Series 4540 High Pressure Reactors, 600 & 1200 mL

**This series of stirred reactors has been designed for users who need higher operating pressures** than the 1900 to 2900 psi offered by the General Purpose Reactors, but do not require the high operating temperatures provided by the Series 4570 High Pressure, High Temperature Reactors. The 4540 series reactors offer working pressures to 5000 psi (345 bar) at temperatures to 350 °C.

These vessels have been designed with outside dimensions comparable to the Series 4520 and 4530 Reactors so that they can use the same support system, stirrer drive and heater as these popular general purpose models. This provides not only an attractively priced high pressure/moderate temperature system, but also reactors that can be interchanged with the 1 and 2 liter sizes. The thicker walls required for higher operating pressures reduce the volumes of these reactors to 600 and 1200 mL.

These reactors can be used in either the bench top or floor stand mountings. While the 1200 mL reactor is offered as a fixed head bench top model; it is too tall and too heavy to be handled comfortably on a standard height bench top. It is recommended that the floor stand support option should be selected unless the user has an adjustable bench top which will accommodate the overall height of the 1200 mL systems.



**Model 4544 High Pressure Bench Top Reactor, 600 mL, Moveable Head, with heater lowered, and a 4848 Controller shown with optional Expansion Modules.**

## 4540

Series 4540 Pressure Reactor System Specifications						
Shaded bar indicates specifications that change within series.						
Model No. - Moveable Vessel	4544	—	4544A	—	4544C	4546C
Model No. - Fixed Head	4545	4547	4545A	4547A		
Approximate Volume, mL	600	1200	600	1200	600	1200
Maximum Pressure (MAWP)	5000 psi (345 bar)					
<b>Maximum Temperature</b>						
with PTFE Flat Gasket	350 °C					
<b>Reactor Details</b>						
Mounting Style	Moveable or Fixed Head					
Stand Type	Bench Top		Floor Stand		Moveable Cart	
Closure	Split-Ring (8 Compression Bolts for Flat Gasket, no Compression Bolts for O-ring)					
Valve Connections	1/4" Male NPT					
Magnetic Stirrer, Model No.	A1120HC6 General Purpose or A2140HC Footless					
Maximum Torque	16 Inch-Pounds					
Impeller(s), 6-Blade	2 (1.75" dia.)					
Stirrer Motor	1/8 hp		1/8 hp		1/4 hp	
Pressure Gage, Size	4.5 inches					
Range	0-5000 psi (345 bar)					
Temperature Measurement	Thermowell					
Cooling Coil (optional)	Serpentine or Loop					
Bottom Drain Valve (BDV) (optional)	N/A		1" NPS		N/A	
Lift Mechanism	N/A	Pneumatic	N/A	Pneumatic	N/A	N/A
<b>Heater Style</b>						
Calrod						
Heater Power, Watts	1000 / 1500	1500 / 2000	1000 / 1500	1500 / 2000	1300	1300
<b>Electrical Supply</b>						
Volts, AC	115 / 230					
Maximum Load, amps, 115 / 230	12 / 9					
<b>Cylinder Dimensions</b>						
I.D. x Depth, inches	3.25 x 4.7	3.25 x 9.8	3.25 x 4.7	3.25 x 9.8	3.25 x 4.7	3.25 x 9.8
Vessel Assembly Weight, pounds	4544: 50 4545: 53	65	4544A: 50 4545A: 53	65	50	61
Cylinder Weight, pounds	18	29	18	29	18	29
<b>Reactor Dimensions</b>						
Width x Depth w/o Controller, inches	17 x 24		21 x 28		35 x 18	
Height, inches	38	48	63		50	
Cylinder Weight, pounds	125	135	175	185	175	185
<b>Spare Parts Kit</b>	4549M					
Other options available. See Ordering Guide, visit <a href="http://www.parrinst.com">www.parrinst.com</a> , or call for more information. Weights and dimensions are estimated from the base model. Final weights and dimensions will vary based on options selected.						

Series Number:

# 4540

## Series 4540 High Pressure Reactors, 600 & 1200 mL

### Index to Options

Option	Page
--------	------

Certification	8
---------------	---

Materials of Construction	10
---------------------------	----

Magnetic Drive	14
----------------	----

Gaskets & Seals	18
-----------------	----

Stirrer Motor	118
---------------	-----

Rupture Disc	124
--------------	-----

Pressure Gage	125
---------------	-----

Cooling Coil	129
--------------	-----

Bottom Drain Valve	131
--------------------	-----

4848 Reactor Controller	102
-------------------------	-----

4871 Process Controller	109
-------------------------	-----

A2110E Motor Controller	114
-------------------------	-----

Custom Option	Page
---------------	------

Stirrers	120
----------	-----

Heaters	116
---------	-----

External Valves & Fittings	138
----------------------------	-----

Solids Charging Ports	128
-----------------------	-----

Condensers	123
------------	-----

Electrical Glands	137
-------------------	-----

Catalyst Addition Device	128
--------------------------	-----

Catalyst Baskets	122
------------------	-----

Relief Valves	125
---------------	-----

Windows	136
---------	-----

Gear Drives	119
-------------	-----

Explosion Proof Options	134
-------------------------	-----

Liquid Sampling	130
-----------------	-----

Accessories	Page
-------------	------

Liners	129
--------	-----

Spare Parts Kits	137
------------------	-----

Pressure Hoses	133
----------------	-----

Check Valves	125
--------------	-----

Liquid Pipettes	127
-----------------	-----

Gas Burettes	126
--------------	-----



1200 mL Fixed Head, and  
600 mL Moveable Reaction  
Vessels.



Model 4546C Moveable Head Reactor on a Moveable Cart, 1200 mL, and  
a 4848 Reactor Controller shown with optional Expansion Modules.



# Series 4540 Ordering Guide

The Order No. for the Base System is: **454\_\_-T-SS-M-115-VS.12-2000-4848**

A composite identification number to be used when ordering a 4540 Series Reactor can be developed by combining individual symbols from the separate sections below. For more information on how to use this ordering guide, [please see page 27](#).

## A Base Model

Model No.	Size	Vessel Style
4544	600 mL	Moveable Head, Bench Top
4544A	600 mL	Moveable Head, Floor Stand
4544C	600 mL	Moveable Head, Moveable Cart
4545	600 mL	Fixed Head, Bench Top
4545A	600 mL	Fixed Head, Stationary Floor Stand
4546C	1200 mL	Moveable Head, Moveable Cart
4547	1200 mL	Fixed Head, Bench Top
4547A	1200 mL	Fixed Head, Stationary Floor Stand

## B Gasket / Maximum Temperature

-T	PTFE Flat Gasket, 350 °C
----	--------------------------

## C Materials of Construction

-SS	T316 Stainless Steel
-MO	Alloy 400
-IN	Alloy 600
-HB	Alloy B-2 / B-3
-HC	Alloy C-276
-CS	Alloy 20
-TI2	Titanium Grade 2*
-TI4	Titanium Grade 4*
-NI	Nickel 200*
-ZR702	Zirconium Grade 702*
-ZR705	Zirconium Grade 705*

\* Maximum Pressure and/or Temperature are limited.  
See [page 10](#) or [page 24](#) for complete list of available alloys.

## D Magnetic Stirrer Drive

-M	General Purpose, 16 in-lb
-HD	Heavy Duty, 60 in-lb
-XHD	Extra Heavy Duty, 120 in-lb
-FMD1	Footless, General Purpose, 16 in-lb
-FMD2	Footless, Heavy Duty, 60 in-lb
-FMD3	Footless, Extra Heavy Duty, 120 in-lb

## E Mag. Drive Material of Construction

-MOC Symbol	Indicates Material of Construction
-------------	------------------------------------

## F Electrical Supply

-115	115 VAC
-230	230 VAC

## G Motor Option

-VS .12	Variable Speed, 1/8 hp
-VS .25	Variable Speed, 1/4 hp
-XP .25	Explosion Proof, Variable Speed, 1/4 hp
-AM .25	Air Motor, 1/4 hp

## H Pressure Gage

-10000	10000 psi / 690 bar
-7500	7500 psi / 517 bar
-5000	5000 psi / 345 bar
-3000	3000 psi / 207 bar

## I Internal Cooling Coil

-SC	Serpentine Coil
-CL	Single Cooling Loop

## J Bottom Drain Valve

-BDV	Bottom Drain Valve, 1" NPS
------	----------------------------

## K Controller

-4848 (included in base system)	PID Control, Ramp & Soak Programming, Motor Speed Control, and Data logging with Software. (RS-485 to USB cable not included) For use with up to three additional display modules.
-4848B	Same as above but for use with up to six additional display modules.
-A2110E	Motor Controller
-4871	Process Controller (for enhanced control options)

See [Chapter 6](#) for a complete list of controllers and options.

## L 4848 Controller Options

-TDM	Tachometer Display Module
-MCM	Motor Control Module w/Tachometer
-PDM	Pressure Display Module
-HTM	High Temperature Cut Off Module
-ETLM	External Temperature Limit Module
-MTM*	Motor Torque Module
-SVM	Solenoid Valve Module (for cooling control)
-A1925E4	RS-485 to USB Cable for 4848 Controller (required for data logging)
-A1925E6	RS-485 to USB Converter, isolated, 30-ft
-A3504HC	SpecView Software Package for 4838/4848

\* The MTM must be installed in conjunction with the MCM.

## M Custom Options (List All Desired)

-AS	Anchor Stirrer
-PS	Paddle Stirrer
-GE	Gas Entrainment Stirrer
-SP	Spiral Stirrer
-BF	Removeable Baffle Set
-CAD	Internal Catalyst Addition Device
-XCAD	External Catalyst Addition Device
-SCP	Solids Charging Port (Ball Valve)
-RC	Reflux Condenser
-RTC	Reflux/Take-Off Condenser
-WJ	Welded Jacket
-ABH	Aluminum Block Heater w/ Cooling Channels

See [Chapter 7](#) for a complete list of optional accessories.

## N Certifications

-ASME	ASME Documentation
-CE	CE Documentation
-P	Parr Certification

## O Spare Parts Kit

-4549M	Spare Parts Kit for 4540 Series
--------	---------------------------------

Please note that all options and combinations are not compatible with all models.

Series Number:

# 4550

Type:  
**General Purpose**

Stand:  
**Floor Stand or Cart**

Mounting Style:  
**Moveable or  
Fixed Head**

Vessel Sizes, Gallons (Liters):  
**1 (3.75) and 2 (7.99)**

Standard Pressure  
MAWP Rating, psi (bar):  
**1900 (131)**

Standard Maximum  
Operating Temp., °C:  
**225 w/ FKM O-ring**  
**300 w/ FFKM O-ring**  
**350 w/ PTFE Flat Gasket**

## Series 4550 Floor Stand Reactors, 1 & 2 Gallon

**These 4550 Reactors extend the size range of the 4530 Series**

to 1 and 2 gallon (3.75 and 7.99 liter) sizes, providing excellent options for pilot plant studies.

These reactors are available with an FKM O-ring seal for operating temperatures to 225 °C, and FFKM O-ring for temperatures to 300 °C, or with a flat, PTFE gasket for operating temperatures up to 350 °C maximum.

Both fixed head and moveable head designs are available. The moveable head, Model 4551 and 4552, cart reactors are designed so that they can be opened or closed conveniently without removing the cylinder from the heater and without auxiliary handling equipment. The split-ring sections can be moved into place from the sides, and the compression bolts can be tightened with the vessel in place in its heater. The fixed head versions, Model 4553 and 4554, allow the head (and the connections made to it) to remain in place while the cylinder and heater are lowered with the aid of the included pneumatic lift system.

The 1 gallon size is usually recommended for high viscosity polymer studies. An optional bottom drain valve may be added for convenient product recovery. As with the smaller floor stand models, these larger, self-contained systems can be equipped with a variety of attachments, such as condensers, solids charging ports, bottom drain valves, special motors, custom heaters, jacketed vessels and automatic valves and regulators. Because of the higher wattage heaters for these reactors, all models in the 4550 Series require a 230 volt power supply.



**Model 4554 Floor Stand Reactor, Two Gallon, Fixed Head, Pneumatic Lift, Hinged Split-Rings, opened to show Internal Fittings and Serpentine Cooling Coil, with 4848 Reactor Controller shown with optional Expansion Modules.**

## 4550

Series 4550 Pressure Reactor System Specifications				
Shaded bar indicates specifications that change within series.				
Model Number	4551	4552	4553	4554
Approximate Volume, Gallon (Liter)	1 (3.75)	2 (7.99)	1 (3.75)	2 (7.99)
Maximum Pressure (MAWP)	1900 psi (131 bar)			
Maximum Temperature				
with FKM O-ring	225 °C			
with FFKM O-ring	300 °C			
with PTFE Flat Gasket	350 °C			
Reactor Details				
Mounting Style	Moveable		Fixed Head	
Stand type	Moveable Cart		Floor Stand	
Closure	Split-Ring (10 Compression Bolts for Flat Gasket, No Compression Bolts for O-ring)			
Valve Connections	1/4" NPT Male			
Magnetic Stirrer, Model No.	A1180HC General Purpose or A2160HC Footless			
Maximum Torque	60 Inch-Pounds			
Impeller(s), 6-Blades	2 (3.85" dia.)			
Stirrer Motor	1/2 hp variable speed			
Pressure Gage, Size	4.5 inches			
Range	0-2000 psi (138 bar)			
Temperature Measurement	Thermowell			
Cooling Coil (optional)	Serpentine			
Bottom Drain Valve (BDV) (optional)	3/8" NPT			
Lift Mechanism (optional)	N/A		Pneumatic	
Heater Style	Calrod			
Heater Power, Watts	2250	2700	2250	2700
Electrical Supply				
Volts, AC	230			
Maximum Load, amps, 230	13	15	13	15
Cylinder Dimensions				
I.D. x Depth, inches	6.0 x 8.6	6.0 x 17.2	6.0 x 8.6	6.0 x 17.2
Vessel Assembly Weight, pounds	96	116	111	131
Cylinder Weight, pounds	33	52	33	52
Reactor/Stand Dimensions				
Width x Depth w/o Controller, inches	35 x 18		20 x 31	
Height, inches	50		75	
Weight, pounds	265	295	315	345
Spare Parts Kit	4559M			
Other options available. See Ordering Guide, visit <a href="http://www.parrinst.com">www.parrinst.com</a> , or call for more information. Weights and dimensions are estimated from the base model. Final weights and dimensions will vary based on options selected.				

Series Number:

# 4550

## Index to Options

Option	Page
Certification	8
Materials of Construction	10
Magnetic Drive	14
Gaskets & Seals	18
Stirrer Motor	118
Rupture Disc	124
Pressure Gage	125
Cooling Coil	129
Bottom Drain Valve	131
4848 Reactor Controller	102
4871 Process Controller	109
A2110E Motor Controller	114

## Custom Option Page

Stirrers	120
Heaters	116
External Valves & Fittings	138
Solids Charging Ports	128
Condensers	123
Electrical Glands	137
Catalyst Addition Device	128
Catalyst Baskets	122
Relief Valves	125
Windows	136
Gear Drives	119
Explosion Proof Options	134
Liquid Sampling	130

## Accessories Page

Liners	129
Spare Parts Kits	137
Pressure Hoses	133
Check Valves	125
Liquid Pipettes	127
Gas Burettes	126

## Series 4550 Floor Stand Reactors, 1 & 2 Gallon



The innovative Parr Hinged Split-Rings on the 4553 and 4554 add to a safe vessel removal routine. Simply loosen the compression bolts, unlatch the split-ring closures, and pivot the split-rings out of the way.



4551 Moveable Head Reactor on Moveable Cart, 1 Gallon, with Bottom Drain Valve, and a 4848 Temperature Controller shown with optional Expansion Modules.



4553 Floor Stand Reactor, 1 Gallon, Fixed Head, with Gear Drive, Hinged Split-Rings, and heater engaged.

# Series 4550 Ordering Guide

The Order No. for the Base System is: **455\_\_-T-SS-HD-230-VS.50-2000-4848**

A composite identification number to be used when ordering a 4550 Series Reactor can be developed by combining individual symbols from the separate sections below. For more information on how to use this ordering guide, [please see page 27](#).

A Base Model		
Model No.	Size	Vessel Style
4551	1 Gallon	Moveable Head, Moveable Cart
4552	2 Gallon	Moveable Head, Moveable Cart
4553	1 Gallon	Fixed Head, Stationary Floor Stand
4554	2 Gallon	Fixed Head, Stationary Floor Stand

B Gasket / Maximum Temperature	
-OV	FKM O-ring, 225 °C
-OK	FFKM O-ring, 300 °C
-T	PTFE Flat Gasket, 350 °C

C Materials of Construction	
-SS	T316 Stainless Steel
-MO	Alloy 400
-IN	Alloy 600
-HB	Alloy B-2 / B-3
-HC	Alloy C-276
-CS	Alloy 20
-Ti2	Titanium Grade 2
-Ti4	Titanium Grade 4
-ZR702	Zirconium Grade 702
-ZR705	Zirconium Grade 705

See [page 10](#) or [24](#) for complete list of available alloys.

D Magnetic Stirrer Drive	
-HD	Heavy Duty, 60 in-lb
-XHD	Extra Heavy Duty, 120 in-lb
-FMD2	Footless, Heavy Duty, 60 in-lb
-FMD3	Footless, Extra Heavy Duty, 120 in-lb

E Mag. Drive Material of Construction	
-MOC Symbol	Indicate Material of Construction

F Electrical Supply	
-230	230 VAC

G Motor Option	
-VS .50	Variable Speed, 1/2 hp
-XP .50	Explosion Proof Variable Speed, 1/2 hp
-AM .50	Air Motor, 1/2 hp
-VS .75	Variable Speed, 3/4 hp
-GDD	Geared Direct Drive (Fixed Head Units Only)

H Geared Direct Drive Ratio*	
-3D	3:1, 0-600 rpm
-5D	5:1, 0-360 rpm
-10D	10:1, 0-180 rpm

\* For Geared Direct Drive Motor Option Only.

I Pressure Gage	
-2000	2000 psi / 138 bar
-1000	1000 psi / 69 bar
-600	600 psi / 40 bar
-200	200 psi / 14 bar
-100	100 psi / 7 bar

J Internal Cooling Coil	
-SC	Serpentine Coil

K Bottom Drain Valve	
-BDV	Bottom Drain Valve 3/8" NPT

L Controller	
-4848 (included in base system)	PID Control, Ramp & Soak Programming, Motor Speed Control, and Data logging with Software. (RS-485 to USB cable not included) For use with up to three additional display modules.
-4848B	Same as above but for use with up to six additional display modules.
-A2110E	Motor Controller
-4871	Process Controller (for enhanced control options)

See [Chapter 6](#) for a complete list of controllers and options.

M 4848 Controller Options	
-TDM	Tachometer Display Module
-MCM	Motor Control Module w/Tachometer
-PDM	Pressure Display Module
-HTM	High Temperature Cut Off Module
-ETLM	External Temperature Limit Module
-MTM*	Motor Torque Module
-SVM	Solenoid Valve Module (for cooling control)
-A1925E4	RS-485 to USB Cable for 4848 Controller (required for data logging)
-A1925E6	RS-485 to USB Converter, isolated, 30-ft
-A3504HC	SpecView Software Package for 4838/4848

\* The MTM must be installed in conjunction with the MCM.

N Custom Options (List All Desired)	
-AS	Anchor Stirrer
-PS	Paddle Stirrer
-SA	Spiral Stirrer
-GE	Gas Entrainment Stirrer
-BF	Removeable Baffle Set
-CAD	Internal Catalyst Addition Device
-XCAD	External Catalyst Addition Device
-SCP	Solids Charging Port (Ball Valve)
-RC	Reflux Condenser
-RTC	Reflux/Take-Off Condenser
-WJ	Welded Jacket
-ABH	Aluminum Block Heater w/ Cooling Channels

See [Chapter 7](#) for a complete list of optional accessories.

O Certifications	
-ASME	ASME Documentation
-CE	CE Documentation
-P	Parr Certification

P Spare Parts Kit	
-4559M	Spare Parts Kit for 4550 Series

Please note that all options and combinations are not compatible with all models.

Series Number:

# 4555

Type:  
**General Purpose**

Stand:  
**Floor Stand**

Mounting Style:  
**Moveable or  
Fixed Head**

Vessel Sizes, Gallons (Liters):  
**2.6 (10) and 5 (18.75)**

Standard Pressure  
MAWP Rating, psi (bar):  
**1900 (131)**

Standard Maximum  
Operating Temp., °C:  
**225 w/ FKM O-ring  
300 w/ FFKM O-ring  
350 w/ PTFE Flat Gasket**

## Series 4555 Floor Stand Reactors, 2.6 & 5 Gallon

### **The Model 4555 and 4557 Reactors with their 5 gallon (18.75 L) capacity are the largest stirred reactors offered by Parr.**

The 4556 and 4558 Models are similar units with a 10 liter (2.6 gal) volume which falls between the larger 5 gallon design and the smaller 1 and 2 gallon models in the 4550 Series. Vessel styles are offered in a moveable head or fixed head design.

These reactors are available with an FKM O-ring seal for operating temperatures to 225 °C, and FFKM O-ring for temperatures to 300 °C, or with a flat, PTFE gasket for operating temperatures up to 350 °C maximum.

In the moveable head design (see page 21), the vessel is held in a support system which minimizes the physical effort required to handle these heavy components. The hoist is attached to a support column which provides a convenient means for lifting the head and cylinder out of the stand. These components may be transferred to the holding position on the right side of the stand. Vessels equipped with a bottom drain valve will probably remain in the heater most of the time, but can be lifted out when necessary.

The fixed head support stand features hinged split-rings that swing to either side allowing the head to remain fixed to the stand while a pneumatic lift allows the cylinder to be raised and lowered. When lowered, the cylinder can be slid forward for cleaning and servicing.

These reactors are generally used for pilot plant or for custom chemical production purposes, usually with a variety of attachments added to the basic units. Various heaters, larger motors, heavier stirrer drives and remote controls appropriate to the size of these reactors have been designed and are available.

***Modified versions of these units are available with higher working pressures and temperatures.***



**Hinged Split-Rings open to reveal Serpentine Cooling Coil, with Heater and Vessel lowered via Pneumatic Lift.**



**4557 Floor Stand Reactor, 5 Gallon, Fixed Head, 3-zone Band Heater, with Split-Rings and Pneumatic Lift.**

## 4555

Series 4555 Pressure Reactor System Specifications				
Shaded bar indicates specifications that change within series.				
Model Number	4555	4556	4557	4558
Approximate Volume, Gallon (Liter)	5 (18.75)	2.6 (10)	5 (18.75)	2.6 (10)
Maximum Pressure (MAWP)	1900 psi (131 bar)			
<b>Maximum Temperature</b>				
with FKM O-ring	225 °C			
with FFKM O-ring	300 °C			
with PTFE Flat Gasket	350 °C			
<b>Reactor Details</b>				
Mounting Style	Moveable		Fixed Head	
Stand Type	Table Floor Stand		Floor Stand	
Closure	Split-Ring (12 Compression Bolts for Flat Gasket, no Compression Bolts for O-ring)			
Valve Connections	3/8" NPT Male			
Magnetic Stirrer, Model No.	A1750HC Heavy Duty or A2160HC Footless			
Maximum Torque	60 Inch-Pounds			
Impeller(s), 6-Blades	2 (5.25" dia.)	2 (3.85" dia.)	2 (5.25" dia.)	2 (3.85" dia.)
Stirrer Motor	3/4 hp variable speed			
Pressure Gage, Size	4.5 inches			
Range	0-2000 psi (138 bar)			
Temperature Measurement	Thermowell			
Cooling Coil	Serpentine			
Bottom Drain Valve (BDV) (optional)	1.0" NPT			
Lift Mechanism	Manual Hoist		Pneumatic	
<b>Heater Style</b>	Ceramic, 3-zone	Band Heater, 3-zone	Band Heater, 3-zone	
Heater Power, Watts	4500	4250	5500	3300
<b>Electrical Supply</b>				
Volts, AC	230-1P or 400-415V 3-Phase "Y"			
Maximum Load, amps	1P-30 amps / 3P-15 amps/leg			
<b>Cylinder Dimensions</b>				
I.D. x Depth, inches	9.5 x 16.3	7.75 x 12.2	9.5 x 16.3	7.75 x 12.2
Vessel Assembly Weight, pounds	354	206	355	209
Cylinder Weight, pounds	157	97	157	97
<b>Reactor Dimensions</b>				
Width x Depth w/o Controller, inches	63 x 25		31 x 43	
Height, inches	91		95	87
Weight, pounds	1000	900	1000	900
<b>Spare Parts Kit</b>	4559PCM			
Other options available. See Ordering Guide, visit <a href="http://www.parrinst.com">www.parrinst.com</a> , or call for more information. Weights and dimensions are estimated from the base model. Final weights and dimensions will vary based on options selected.				

**Power Requirements**

Typical power requirements for Parr's large, electrically heated reactors are 40 amp single phase or 3-Phase power sources. Users are advised to have a qualified electrician determine and install an appropriate mains power supply for the large reactor system.

Large reactor systems with lower electrical power requirements, such as low temperature applications are available for use with typical 20 amp, 230 volt sources.

Contact Parr Technical Sales staff for assistance with electrical specifications.

# Series 4555 Floor Stand Reactors, 2.6 & 5 Gallon

## Index to Options

Option	Page
Certification	8
Materials of Construction	10
Magnetic Drive	14
Gaskets & Seals	18
Stirrer Motor	118
Rupture Disc	124
Pressure Gage	125
Cooling Coil	129
Bottom Drain Valve	131
4848 Reactor Controller	102
4871 Process Controller	109
A2110E Motor Controller	114

## Custom Option

Custom Option	Page
Stirrers	120
Heaters	116
External Valves & Fittings	138
Solids Charging Ports	128
Condensers	123
Electrical Glands	137
Catalyst Addition Device	128
Catalyst Baskets	122
Relief Valves	125
Windows	136
Gear Drives	119
Explosion Proof Options	134
Liquid Sampling	130

## Accessories

Accessories	Page
Liners	129
Spare Parts Kits	137
Pressure Hoses	133
Check Valves	125
Liquid Pipettes	127
Gas Burettes	126



5 Gallon Stirred Vessel in stand with stirrer engaged.



4555 Table Floor Stand Reactor, 5 Gallon Moveable Vessel with Head removed from Vessel, Manual Hoist, and a 4848M Controller.



# Series 4555 Ordering Guide

The Order No. for the Base System is: **455\_\_-T-SS-HD-230-VS.75-2000-SC-C3-4848-ASME**

A composite identification number to be used when ordering a 4555 Series Reactor can be developed by combining individual symbols from the separate sections below. For more information on how to use this ordering guide, [please see page 27](#).

A Base Model		
Model No.	Size	Vessel Style
4555	5 Gallon	Moveable Head
4556	10 Liter	Moveable Head
4557	5 Gallon	Fixed Head
4558	10 Liter	Fixed Head

B Gasket / Maximum Temperature	
-OV	FKM O-ring, 225 °C
-OK	FFKM O-ring, 300 °C
-T	PTFE Flat Gasket, 350 °C

C Materials of Construction	
-SS	T316 Stainless Steel
-MO	Alloy 400
-IN	Alloy 600
-HB	Alloy B-2 / B-3
-HC	Alloy C-276
-CS	Alloy 20
-TI2	Titanium Grade 2
-TI4	Titanium Grade 4
-ZR702	Zirconium Grade 702
-ZR705	Zirconium Grade 705

See [page 10](#) or [24](#) for complete list of available alloys.

D Magnetic Stirrer Drive	
-HD	Heavy Duty, 60 in-lb
-XHD	Extra Heavy Duty, 120 in-lb
-FMD2	Footless Magnetic Drive, 60 in-lb
-FMD3	Footless Magnetic Drive, 120 in-lb

E Mag. Drive Material of Construction	
-MOC Symbol	Indicate Material of Construction

F Electrical Supply	
-230	230 VAC, Single Phase
-400	400-415V 3-Phase "Y"

G Motor Option	
-VS .75	Variable Speed, 3/4 hp
-XP .75	Explosion Proof Variable Speed, 3/4 hp
-AM .100	Air Motor, 1 hp
-GDD	Geared Direct Drive (Fixed Head Only)

H Geared Direct Drive Ratio*		I Pressure Gage	
-3D	3:1, 0-600 rpm	-2000	2000 psi / 138 bar
-5D	5:1, 0-360 rpm	-1000	1000 psi / 69 bar
-10D	10:1, 0-180 rpm	-600	600 psi / 40 bar
* for -GDD Motor Option Only		-200	200 psi / 14 bar
		-100	100 psi / 7 bar

J Internal Cooling Coil	
-SC	Serpentine Coil

K Bottom Drain Valve	
-BDV	Bottom Drain Valve, 1" NPT

L Heater Options	
-C3	Ceramic, 3-zone (4555 only)
-B3	Band Heaters, 3-zone
-WJ	Welded Jacket
-FM	Flexible Mantle Heater, 1-zone, 2500 W, 200 °C Max.

M Head Lift Mechanism (Table Floor Stand only)	
-EH	Electric Hoist (115 VAC)

N Controller	
-4848 (included in base system)	PID Control, Ramp & Soak Programming, Motor Speed Control, and Data logging with Software. (RS-485 to USB cable not included) For use with up to three additional display modules.
-4848B	Same as above but for use with up to six additional display modules.
-A2110E	Motor Controller
-4871	Process Controller (for enhanced control options)

See [Chapter 6](#) for a complete list of controllers and options.

O 4848 Controller Options	
-TDM	Tachometer Display Module
-MCM	Motor Control Module w/Tachometer
-PDM	Pressure Display Module
-HTM	High Temperature Cut Off Module
-ETLM	External Temperature Limit Module
-MTM*	Motor Torque Module
-SVM	Solenoid Valve Module (for cooling control)
-A1925E6	RS-485 to USB Converter, isolated, 30-ft
-A2208E	RS-485 Daisy Chain for Multiple Controller (must be used with A1925E6)
-A3504HC	SpecView Software Package for 4838/4848

\* The MTM must be installed in conjunction with the MCM.

P Custom Options (List All Desired)	
-AS	Anchor Stirrer
-PS	Paddle Stirrer
-SA	Spiral Stirrer
-GE	Gas Entrainment Stirrer
-BF	Removeable Baffle Set
-XCAD	External Catalyst Addition Device
-SCP	Solids Charging Port (Ball Valve)
-RC	Reflux Condenser
-RTC	Reflux/Take-Off Condenser
-WJ	Welded Jacket
-ABH	Aluminum Block Heater

See [Chapter 7](#) for a complete list of optional accessories.

Q Certifications	
-ASME	ASME Documentation
-CE	CE Documentation
-P	Parr Certification

R Spare Parts Kit	
-4559PCM	Spare Parts Kit for 4555 Series

Please note that all options and combinations are not compatible with all models.

Series Number:

# 4560

Type:  
**Mini**

Stand:  
**Bench Top**

Mounting Style:  
**Moveable or  
Fixed Head**

Vessel Sizes, mL:  
**100 - 600**

Standard Temperature  
MAWP Rating, psi (bar):  
**3000 (207)**

High Temperature (HT)  
MAWP Rating, psi (bar):  
**2000 (138)**

Standard Maximum  
Operating Temp., °C:  
**225 w/ FKM O-ring**  
**300 w/ FFKM O-ring**  
**350 w/ PTFE Flat Gasket**

High Temperature (HT)  
Maximum Operating  
Temperature, °C:  
**500 w/ FG Flat Gasket**

## Series 4560 Mini Reactors, 100-600 mL

**These are the most popular of all Parr Stirred Reactors.** Although they are called “Mini” reactors, they offer a range of sizes large enough to work with significant sample sizes, yet small enough to be handled with ease.

They are offered in both fixed head and moveable vessel styles and are available with an FKM O-ring seal for operating temperatures to 225 °C, an FFKM O-ring for temperatures to 300 °C, or with a flat, PTFE gasket for operating temperatures to 350 °C.

Choosing the high temperature option (HT) boosts the maximum temperature to 500 °C, but reduces the MAWP to 2000 psi (138 bar). Standard Mini reactors can be converted to high temperature reactors (500 °C max temperature and 2000 psi MAWP) by changing the head assembly (contains cone connections, high temperature valves, and graphoil gasket) replacing the heater with a ceramic fiber heater and replacing the split-ring. Contact Parr Instrument Company for details.



**4566 Bench Top Mini Reactor, 300 mL, Fixed Head, Drop-Band Split-Ring, and a 4848 Controller shown with optional Expansion Modules.**

Although internal and external space is limited in these small vessels, gas entrainment impellers, catalyst baskets, condensers and other options are available. All reactors in this series can also be easily converted from one size to another by simply substituting a longer or shorter cylinder with the corresponding internal fittings and heaters.

The support system for these Mini Reactors is designed specifically to provide stability at stirring speeds up to 1700 rpm, in a compact mounting small enough to fit into a laboratory hood. The support system can also be adapted to accept any of the smaller vessels from the 4590 Micro Reactor Series.



**4560 Reactor Vessels from left to right, 300 mL, 100 mL, 450 mL, 160 mL, and 600 mL.**

## 4560

Series 4560 Pressure Reactor System Specifications											
Shaded bar indicates specifications that change within series.											
Model Number	4561	4562	4563	4564	4565	4566	4567	4568	4566B	4566C	
Approximate Volume, mL	300	450	600	160	100	300	450	600	160	100	
Maximum Pressure (MAWP)	3000 psi (207 bar, 200 bar for CE orders)										
HT Max. Pressure (MAWP)	2000 psi (138 bar)										
<b>Maximum Temperature</b>											
with FKM O-ring	225 °C										
with FFKM O-ring	300 °C										
with PTFE Flat Gasket	350 °C										
with Flexible Graphite Flat Gasket (HT)	500 °C			N/A		500 °C			N/A		
<b>Reactor Details</b>											
Mounting Style	Moveable					Fixed Head					
Stand Type	Bench Top										
Closure	Split-Ring (6 Compression Bolts for Flat Gasket, no Compression Bolts for O-ring)										
Valve Connections	1/8" NPT Male										
Magnetic Stirrer, Model No.	A1120HC6										
Maximum Torque	16 Inch-Pounds										
Impeller(s), 4-Blade, 1.38" dia.	1	1	2	1	1	1	1	2	1	1	
Stirrer Motor	1/8 hp variable speed										
Pressure Gage, Size	3.5 inches										
Range, Standard Temperature	0-3000 psi (207 bar)										
Range, High Temperature	0-2000 psi (138 bar)										
Temperature Measurement	Fixed Thermocouple (Thermowell for special alloys)										
Cooling Coil	Included			Not Included			Included			Not Included	
Style	Single Loop (Optional Serpentine Style)										
Bottom Drain Valve, optional	1/4" NPT (Not available on HT Models)										
<b>Heater Style</b>	Mantle			Clamp-on			Mantle			Clamp-on	
Heater Power, Watts	510	590	780	525			510	590	780	525	
Heater Style w/ HT Option	Ceramic Fiber			N/A			Ceramic Fiber			N/A	
Heater Power, Watts	800	800	1100	N/A			800	800	1100	N/A	
<b>Electrical Supply</b>											
Volts, AC	115 / 230										
Maximum Load, amps, 115 / 230	10 / 5 (14 / 7 High Temperature)										
<b>Cylinder Dimensions</b>											
I.D x Depth, inches	2.5 x 4.0	2.5 x 6.0	2.5 x 8.0	2.5 x 2.0	2.1 x 2.0	2.5 x 4.0	2.5 x 6.0	2.5 x 8.0	2.5 x 2.0	2.1 x 2.0	
Vessel Assembly Weight, pounds	17	21	21	17	18	18	21	22	18	19	
Weight of Cylinder, pounds	3.7	4.9	6.2	2.4	3.3	3.7	4.9	6.2	2.4	3.3	
<b>Reactor Dimensions</b>											
Width x Depth w/o Controller, inches	12 x 18										
Height, inches	28	32	36	28	28	28	32	36	28	28	
Weight, pounds	60	63	66	60	60	62	65	68	60	60	
<b>Spare Parts Kit</b>	4569M (4569HT for High Temperature)										
Other options available. See Ordering Guide, visit <a href="http://www.parrinst.com">www.parrinst.com</a> , or call for more information. Weights and dimensions are estimated from the base model. Final weights and dimensions will vary based on options selected.											

## Series 4560 Mini Reactors, 100-600 mL

## Index to Options

Option	Page
Certification	8
Materials of Construction	10
Magnetic Drive	14
Gaskets & Seals	18
Stirrer Motor	118
Rupture Disc	124
Pressure Gage	125
Cooling Coil	129
Bottom Drain Valve	131
4848 Reactor Controller	102
4871 Process Controller	109
A2110E Motor Controller	114

## Custom Option Page

Stirrers	120
Heaters	116
External Valves & Fittings	138
Solids Charging Ports	128
Condensers	123
Electrical Glands	137
Catalyst Addition Device	128
Catalyst Baskets	122
Relief Valves	125
Windows	136
Gear Drives	119
Explosion Proof Options	134
Liquid Sampling	130

## Accessories Page

Liners	129
Spare Parts Kits	137
Pressure Hoses	133
Check Valves	125
Liquid Pipettes	127
Gas Burettes	126



4566 Bench Top Mini Reactor, 300 mL, Fixed Head, with Aluminum Block Heater, and a 4848 Controller shown with optional Expansion Modules.



Model 4563 Bench Top Mini Reactor, 600 mL, Moveable Head, PTFE Flat Gasket Seal, with vessel disassembled, and a 4848 Controller shown with optional Expansion Modules.

# Series 4560 Ordering Guide

The Order No. for the Base System is: **456\_\_-T-SS-M-115-VS.12-2000-4848**

A composite identification number to be used when ordering a 4560 Series Reactor can be developed by combining individual symbols from the separate sections below. For more information on how to use this ordering guide, [please see page 27](#).

A Base Model		
Model No.	Size	Vessel Style
4561	300 mL	Moveable Head
4562	450 mL	Moveable Head
4563	600 mL	Moveable Head
4564	160 mL*	Moveable Head
4565	100 mL *	Moveable Head
4566	300 mL	Fixed Head
4567	450 mL	Fixed Head
4568	600 mL	Fixed Head
4566B	160 mL*	Fixed Head
4566C	100 mL*	Fixed Head

\* High temperature option not available.

B High Temperature Option	
-No Symbol	Standard Configuration: 3000 psi / 207 bar
-HT	2000 psi / 138 bar @ 500 °C

C Gasket / Maximum Temperature	
-OV	FKM O-ring, 225 °C
-OK	FFKM O-ring, 300 °C
-T	PTFE Flat Gasket, 350 °C
-FG	Flexible Graphite Flat Gasket, 500 °C

D Material of Construction	
-SS	T316 Stainless Steel
-MO	Alloy 400*
-IN	Alloy 600
-HB	Alloy B-2 / B-3*
-HC	Alloy C-276
-CS	Alloy 20*
-Ti2	Titanium Grade 2*
-Ti4	Titanium Grade 4*
-ZR702	Zirconium Grade 702*
-ZR705	Zirconium Grade 705*

\* Not available for HT option

See [page 10](#) or [24](#) for complete list of available alloys.

E Magnetic Stirrer Drive	
-M	General Purpose, 16 in-lb
-FMD1	Footless, 16 in-lb

F Stirrer Drive Material of Construction	
-MOC Symbol	Indicate Material of Construction

G Electrical Supply	
-115	115 VAC
-230	230 VAC

H Motor Option	
-VS .12	Variable Speed, 1/8 hp
-VS .25	Variable Speed, 1/4 hp
-XP .25	Explosion Proof Variable Speed, 1/4 hp
-AM .25	Air Motor, 1/4 hp

I Pressure Gage			
-3000	3000 psi / 207 bar	-600	600 psi / 40 bar
-2000	2000 psi / 138 bar	-200	200 psi / 14 bar
-1000	1000 psi / 69 bar	-100	100 psi / 7 bar

J Internal Cooling Coil	
-CL	Internal Cooling Loop

K Bottom Drain Valve	
-BDV	Bottom Drain Valve (Not Available on High Temperature Vessels)

L Controller	
-4848 (included in base system)	PID Control, Ramp & Soak Programming, Motor Speed Control, and Data logging with Software. (RS-485 to USB cable not included) For use with up to three additional display modules.
-4848B	Same as above but for use with up to six additional display modules.
-A2110E	Motor Controller
-4871	Process Controller (for enhanced control options)

See [Chapter 6](#) for a complete list of controllers and options.

M 4848 Controller Options	
-TDM	Tachometer Display Module
-MCM	Motor Control Module w/Tachometer
-PDM	Pressure Display Module
-HTM	High Temperature Cut Off Module
-ETLM	External Temperature Limit Module
-MTM*	Motor Torque Module
-SVM	Solenoid Valve Module (for cooling control)
-A1925E4	RS-485 to USB Cable for 4848 Controller (required for data logging)
-A1925E6	RS-485 to USB Converter, isolated, 30-ft
-A2208E	RS-485 Daisy Chain for Multiple Controller (must be used with A1925E6)
-A3504HC	SpecView Software Package for 4838/4848

\* The MTM must be installed in conjunction with the MCM.

N Custom Options (List All Desired)	
-AS	Anchor Stirrer
-PS	Paddle Stirrer
-SA	Spiral Stirrer
-GE	Gas Entrainment Stirrer
-BF	Removeable Baffle Set
-SB	Static Catalyst Basket
-CAD	Internal Catalyst Addition Device
-XCAD	External Catalyst Addition Device
-SCP	Solids Charging Port (Ball Valve)
-RC	Reflux Condenser
-RTC	Reflux/Take-Off Condenser
-WJ	Welded Jacket
-ABH	Aluminum Block Heater w/ Cooling Channels

See [Chapter 7](#) for a complete list of optional accessories.

O Certifications	
-ASME	ASME Documentation
-CE	CE Documentation
-P	Parr Certification

P Spare Parts Kit	
-4569M	Spare Parts Kit for 4560 Series
-4569HT	Spare Parts Kit for 4560HT Series

Please note that all options and combinations are not compatible with all models.

Series Number:

# 4570/80

Type:  
**High Temperature /  
High Pressure**

Stand:  
**Bench Top,  
Floor Stand or Cart**

Mounting Style:  
**Moveable or  
Fixed Head**

Vessel Sizes, mL:  
**250-5500**

Standard Pressure  
MAWP Rating, psi (bar):  
**4570: 5000 (345)  
4580: 3000 (207)**

Maximum Operating  
Temperature, °C:  
**500 w/ FG Flat Gasket**

## Series 4570/80 HP/HT Reactors, 250-5500 mL

**Parr offers a number of different reactors in the 4570 and 4580 Series** in a variety of sizes and with different mountings for operating pressures to 5000 psi (345 bar) and temperatures to 500 °C.

### 4571 - 4572 Reactors

These are 1000 and 1800 mL moveable head reactors mounted in moveable carts.

### 4577 - 4578 Reactors

These are 1000 and 1800 mL fixed head reactors mounted on a floor stand with pneumatic lift.

### 4575 - 4576A Reactors

These are 500 and 250 mL bench top reactors with 5000 psi (345 bar) and 500 °C ratings. They are available as either moveable or fixed head vessels.

### 4581 - 4582 Reactors

These 1 gallon (3.75 L) and 1.5 gallon (5.5 L) reactors are designed for 3000 psi (207 bar) maximum pressure with a 500 °C maximum working temperature and mounted on moveable carts.

### 4583 - 4584 Reactors

These are 1 gallon (3.75 L) and 1.5 gallon (5.5 L) fixed head reactors mounted on floor stands with pneumatic lift.

All of these reactors have been designed with suitable valves, fittings and modifications to the vessel itself to operate at the higher temperature and pressure ratings.

Flat, flexible graphite (FG) gaskets are used for temperatures in the higher range to 500 °C. These can be replaced with PTFE gaskets for procedures in which the temperature will not exceed 350 °C.



The Series 4570/80 High Temperature/High Pressure Reactors come in three configurations, from left to right: Bench Top (250 & 500 mL only), Floor Stand, and Cart.



Model 4578 High Temperature/High Pressure Reactor, Floor Stand, 1800 mL, Fixed Head, with Heater and Pneumatic Lift.

## 4570/80

Series 4570/80 Pressure Reactor System Specifications						
Shaded bar indicates specifications that change within series.						
<b>Model No. – Moveable Vessel</b>	<b>4571</b>	<b>4572</b>	<b>4581</b>	<b>4582</b>	<b>4575B</b>	<b>4576B</b>
<b>Model No. – Fixed Head</b>	<b>4577</b>	<b>4578</b>	<b>4583</b>	<b>4584</b>	<b>4575A</b>	<b>4576A</b>
<b>Approximate Volume, mL</b>	1000	1800	3750	5500	500	250
<b>Maximum Pressure, MAWP</b>	5000 psi (345 bar)		3000 psi (207 bar, 200 bar for CE orders)		5000 psi (345 bar)	
<b>Maximum Temperature</b>						
with Flexible Graphite Flat Gasket	500 °C					
<b>Reactor Details</b>						
Stand Type	Cart / Floor Stand		Cart / Floor Stand		Bench Top	
Closure (Compression Bolts)	Split-Ring (12 Compression Bolts for Flat Gasket)		Split-Ring (16 Compression Bolts for Flat Gasket)		Split-Ring (8 Compression Bolts for Flat Gasket)	
Valve Connections	1/4" NPT Female					
Magnetic Stirrer, Model No.	A1120HC		A1180HC		A1120HC	
Maximum Torque	16 Inch-Pounds		60 Inch-Pounds		16 Inch-Pounds	
Impeller(s), 6-Blade (4-blade)	2 (2" dia.)		2 (3.5" dia.)		2 (.81" / 1.38" dia.)	
Stirrer Motor, Variable Speed	1/4 hp		1/2 hp		1/8 hp	
Pressure Gage, Size	4.5 inches					
Range	0-5000 psi (345 bar)		0-3000 psi (207 bar)		0-5000 psi (345 bar)	
Temperature Measurement	Thermowell					
Cooling Coil	Included					
Style	Serpentine		Serpentine		Single Loop	
Bottom Drain Valve	1" NPS (Floor stand supports only)					
<b>Heater Style</b>	Calrod: Fixed Head, Ceramic: Removeable					
Heater Power, Watts	2800		2800		1800	1400
<b>Electrical Supply</b>						
Volts, AC	230		230		115 / 230	
Maximum Load, amps, 115 / 230	15		15		9 / 15	
<b>Cylinder Dimensions</b>						
Inside Diameter, inches	3.75 x 6.2	3.75 x 10.5	5.5 x 9.7	5.5 x 15.1	2.5 x 6.6	2.5 x 3.2
Moveable Vessel Assembly Weight, pounds	83	100	124	143	44	38
Fixed Vessel Assembly Weight, pounds	92	109	136	155	44	38
Cylinder Weight, pounds	36	52	53	72	15	9
<b>Reactor Dimensions</b>						
Moveable Width x Depth x Height, in.	Cart: 35 x 18 x 50		Cart: 35 x 18 x 50		Bench Top: 17 x 24 x 42	
Fixed Width x Depth x Height, in.	Floor Stand: 20 x 31 x 75		Floor Stand: 20 x 31 x 75			
Moveable Weight, pounds	245	265	325	355	125	120
Fixed Weight, pounds	265	285	345	375	127	122
<b>Spare Parts Kit</b>	4579M		4589M		4579M	
Other options available. See Ordering Guide, visit <a href="http://www.parrinst.com">www.parrinst.com</a> , or call for more information. Weights and dimensions are estimated from the base model. Final weights and dimensions will vary based on options selected.						

## Series 4570/80 HP/HT Reactors, 250-5500 mL

Model 4581 High Temperature/High Pressure Reactor, with 1 Gallon Moveable Vessel, and a 4848 Reactor Controller with optional Expansion Modules.

## Index to Options

Option	Page
Certification	8
Materials of Construction	10
Magnetic Drive	14
Gaskets & Seals	18
Stirrer Motor	118
Rupture Disc	124
Pressure Gage	125
Cooling Coil	129
Bottom Drain Valve	131
4848 Reactor Controller	102
4871 Process Controller	109
A2110E Motor Controller	114

## Custom Option Page

Stirrers	120
Heaters	116
External Valves & Fittings	138
Solids Charging Ports	128
Condensers	123
Electrical Glands	137
Catalyst Addition Device	128
Catalyst Baskets	122
Relief Valves	125
Windows	136
Gear Drives	119
Explosion Proof Options	134
Liquid Sampling	130

## Accessories Page

Liners	129
Spare Parts Kits	137
Pressure Hoses	133
Check Valves	125
Liquid Pipettes	127
Gas Burettes	126



Model 4576A HP/HT Bench Top Reactor, 250 mL Vessel with Fixed Head.



Model 4575B High Pressure/High Temperature 500 mL Moveable Vessel Assembly.



# Series 4570/80 Ordering Guide

The Order No. for the Base System is: **457\_\_-FG-SS-M-115-VS.\_\_\_-5000-4848**  
**or 458\_\_-FG-SS-HD-230-VS.50-3000-4848**

A composite identification number to be used when ordering a 4570 or 4580 Series Reactor can be developed by combining individual symbols from the separate sections below. For more information on how to use this ordering guide, [please see page 27](#).

## A Base Model

Model	Size	Vessel Style
4571	1000 mL	Moveable Head, Moveable Cart
4572	1800 mL	Moveable Head, Moveable Cart
4577	1000 mL	Fixed Head, Stationary Floor Stand
4578	1800 mL	Fixed Head, Stationary Floor Stand
4575B	500 mL	Moveable Head, Bench Top
4576B	250 mL	Moveable Head, Bench Top
4575A	500 mL	Fixed Head, Bench Top
4576A	250 mL	Fixed Head, Bench Top
4581	1.0 Gallon	Moveable Head, Moveable Cart
4582	1.5 Gallon	Moveable Head, Moveable Cart
4583	1.0 Gallon	Fixed Head, Stationary Floor Stand
4584	1.5 Gallon	Fixed Head, Stationary Floor Stand

## B Gasket / Maximum Temperature

-FG	Flexible Graphite Gasket, 500 °C
-T	PTFE Compression Gasket, 350 °C

## C Materials of Construction

-SS	T316 Stainless Steel
-MO	Alloy 400*
-IN	Alloy 600
-HB	Alloy B-2 / B-3*
-HC	Alloy C-276
-CS	Alloy 20*
-TI2	Titanium Grade 2*
-TI4	Titanium Grade 4*
-ZR702	Zirconium Grade 702*
-ZR705	Zirconium Grade 705*

\*Maximum temperature and/or pressure limited.  
 See [page 10](#) or [24](#) for complete list of available alloys.

## D Magnetic Stirrer Drive

-M	General Purpose, 16 in-lb
-HD	Heavy Duty, 60 in-lb *
-XHD	Extra Heavy Duty, 120 in-lb *
-FMD1	Footless, General Purpose, 16 in-lb.
-FMD2	Footless, Heavy Duty, 60 in-lb **
-FMD3	Footless, Extra Heavy Duty, 120 in-lb *

\* Not available on 4575-76 (250 mL & 500 mL)

## E Mag. Drive Material of Construction

-MOC Symbol	Indicate Material of Construction
-------------	-----------------------------------

## F Electrical Supply

-115	115 VAC (4575-4576 Only)
-230	230 VAC

## G Motor Option

-VS .12	Variable Speed, 1/8 hp (4575-4576 Only)
-VS .25	Variable Speed, 1/4 hp
-VS .50*	Variable Speed, 1/2 hp
-XP .25	Explosion Proof Variable Speed, 1/4 hp
-XP .50*	Explosion Proof Variable Speed, 1/2 hp
-AM .25	Air Motor, 1/4 hp (4575-4576 Only)
-AM .50*	Air Motor, 1/2 hp
-GDD	Geared Direct Drive (Fixed Head Unit Only)

\* For use with -HD Magnetic Stirrer Drive.  
 Only available on 230V systems.

## H Pressure Gage

-5000	5000 psi / 345 bar (4570 Series Only)
-3000	3000 psi / 207 bar
-2000	2000 psi / 138 bar
-1000	1000 psi / 69 bar

## I Bottom Drain Valve

-BDV	Bottom Drain Valve (Not available on 250 mL or Bench Top Systems)
------	---

## J Controller

-4848 (included in base system)	PID Control, Ramp & Soak Programming, Motor Speed Control, and Data logging with Software. (RS-485 to USB cable not included) For use with up to three additional display modules.
-4848B	Same as above but for use with up to six additional display modules.
-A2110E	Motor Controller
-4871	Process Controller (for enhanced control options)

See [Chapter 6](#) for a complete list of controllers and options.

## K 4848 Controller Options

-TDM	Tachometer Display Module
-MCM	Motor Control Module w/Tachometer
-PDM	Pressure Display Module
-HTM	High Temperature Cut Off Module
-ETLM	External Temperature Limit Module
-MTM*	Motor Torque Module
-SVM	Solenoid Valve Module (for cooling control)
-A1925E4	RS-485 to USB Cable for 4848 Controller (required for data logging)
-A1925E6	RS-485 to USB Converter, isolated, 30-ft
-A2208E	RS-485 Daisy Chain for Multiple Controller (must be used with A1925E6)
-A3504HC	SpecView Software Package for 4838/4848

\* The MTM must be installed in conjunction with the MCM.

## L Custom Options (List All Desired)

-AS	Anchor Stirrer
-PS	Paddle Stirrer
-SA	Spiral Stirrer
-GE	Gas Entrainment Stirrer
-BF	Removeable Baffle Set
-SB	Static Catalyst Basket
-DB	Dynamic Catalyst Basket
-CAD	Internal Catalyst Addition Device
-XCAD	External Catalyst Addition Device
-SCP	Solids Charging Port (Ball Valve)
-RC	Reflux Condenser
-RTC	Reflux/Take-Off Condenser
-WJ	Welded Jacket

See [Chapter 7](#) for a complete list of optional accessories.

## M Certifications

-ASME	ASME Documentation
-CE	CE Documentation
-P	Parr Certification

## N Spare Parts Kit

-4579M	Spare Parts Kit for 4570 Series
-4589M	Spare Parts Kit for 4580 Series

Please note that all options and combinations are not compatible with all models.

Series Number:

# 4590

Type:  
**Micro**

Stand:  
**Bench Top**

Mounting Style:  
**Moveable or  
Fixed Head**

Vessel Sizes, mL:  
**25, 50, 100**

Standard Pressure  
MAWP Rating, psi (bar):  
**3000 (207)**

High Pressure (HP)  
MAWP Rating, psi (bar):  
**5000 (345)**

Standard Maximum  
Operating Temp., °C:  
**225 w/ FKM O-ring**  
**300 w/ FFKM O-ring**  
**350 w/ PTFE Flat Gasket**

High Temperature (HT) /  
High Pressure (HP)  
Maximum Operating  
Temperature, °C:  
**500 w/ FG Flat Gasket**  
**(Fixed Head Only)**



Smaller vessel sizes are available in our **Series 2500 Micro Batch System** which includes three reactors in 5 mL or 10 mL. [See page 72.](#)

## Series 4590 Micro Stirred Reactors, 25-100 mL

**These are Parr's smallest individual Stirred Reactors.** They are a good choice for chemists working with very expensive materials, materials only available in small amounts, or those chemists working with hazardous materials. Use of the Series 4590 Reactors helps minimize the quantities of waste products created which may require special disposal procedures. The 4590 systems are now available in high pressure (5000 psi) or high pressure/high temperature (500 °C) versions.

These micro reactors have been designed to provide as many of the features of the larger vessels as possible in the limited space available. All of the standard head fittings are provided, with optional cooling now available with aluminum block heaters with cooling capability, welded jackets or internal cold fingers.

**These systems are offered in both fixed head and moveable head vessel styles** with choices of a self sealing FKM O-ring for temperatures up to 225 °C or with FFKM O-ring for temperatures to 300 °C or with a flat PTFE gasket for temperatures to 350 °C, or with an Flexible Graphite gasket for temperatures to 500 °C with the HP/HT option (for fixed head versions only). A split-ring closure is standard.

All three volumes use the same ceramic fiber heater.

**These micro reactors can be easily converted from one size to another** by simply substituting a larger or smaller cylinder and the corresponding internal fittings. The support system can also be readily adapted to accept any of the vessels from the 4560 Mini Reactor Series. The opportunity to modify these small reactors is restricted because of the limited head space available.



4598 HP/HT Micro Reactor, 100 mL with Fixed Head.

4590

Series 4590 Pressure Reactor System Specifications						
Shaded bar indicates specifications that change within series.						
Model Number	4591	4592	4593	4596	4597	4598
Approximate Volume, mL	25	50	100	25	50	100
Maximum Pressure (MAWP)	3000 psi (207 bar, 200 bar for CE orders)					
HP, HP/HT Max. Pressure (MAWP)	5000 psi (345 bar)					
<b>Maximum Temperature</b>						
with FKM O-ring	225 °C					
with FFKM O-ring	300 °C					
with PTFE Flat Gasket	350 °C					
with FG Flexible Graphite Flat Gasket (HP/HT)	500 °C					
<b>Reactor Details</b>						
Mounting Style	Moveable			Fixed Head		
Stand type	Bench Top					
Closure	Split-Ring (6 Compression Bolts for Flat Gasket, No Compression Bolts for O-ring)					
Valve Connections	1/8" NPT Male, 1/4" NPT Male for HP, 1/4" NPT Female for HP/HT					
Magnetic Stirrer, Model No.	A1120HC6					
Maximum Torque	16 Inch-Pounds					
Impeller, 4-Blade	1 (.81" dia.)					
Stirrer Motor	1/8 hp Variable Speed					
Pressure Gage, Size	3.5 inches					
Range	0-3000 psi (207 bar), 0-5000 psi (345 bar) HP, HP/HT					
Temperature Measurement	Fixed Thermocouple (Thermowell for special alloys)					
Cooling (optional)	Cold Finger					
Bottom Drain Valve	1/4" NPT (Not available on HP or HP/HT models)					
<b>Heater Style</b>	Ceramic Fiber Heater					
Heater Power, Watts	700					
<b>Electrical Supply</b>						
Volts, AC	115 / 230					
Maximum Load, amps, 115 / 230	7 / 4			7 / 4		
Maximum Load, amps, HP/HT, 115 / 230	N/A			7 / 4		
<b>Cylinder Dimensions</b>						
I.D. x Depth, inches	1.0 x 2.0	1.3 x 2.3	1.3 x 4.6	1.0 x 2.0	1.3 x 2.3	1.3 x 4.6
Vessel Assembly Weight, pounds	18	18	19	19	19	20
Cylinder Weight, pounds	3.5	3.1	4.2	3.5	3.1	4.2
<b>Reactor/Stand Dimensions</b>						
Width x Depth w/o Controller, inches	12 x 18					
Height, inches*	27	35	27	35	27	35
Weight, pounds	55	56	56	56	57	57
<b>Spare Parts Kit</b>	4599M (4599HPHT for High Temperature)					
* Add 8-inches to height for Aluminum Block Heater options.						
Other options available. See Ordering Guide, visit <a href="http://www.parrinst.com">www.parrinst.com</a> , or call for more information. Weights and dimensions are estimated from the base model. Final weights and dimensions will vary based on options selected.						

## Series 4590 Micro Stirred Reactors, 25-100 mL

## Index to Options

Option	Page
Certification	8
Materials of Construction	10
Magnetic Drive	14
Gaskets & Seals	18
Stirrer Motor	118
Rupture Disc	124
Pressure Gage	125
Cooling Coil	129
Bottom Drain Valve	131
4848 Reactor Controller	102
4871 Process Controller	109
A2110E Motor Controller	114

Custom Option	Page
Stirrers	120
Heaters	116
External Valves & Fittings	138
Solids Charging Ports	128
Condensers	123
Electrical Glands	137
Catalyst Addition Device	128
Catalyst Baskets	122
Relief Valves	125
Windows	136
Gear Drives	119
Explosion Proof Options	134
Liquid Sampling	130

Accessories	Page
Liners	129
Spare Parts Kits	137
Pressure Hoses	133
Check Valves	125
Liquid Pipettes	127
Gas Burettes	126



Model 4598 HP/HT stirred vessel,  
100 mL with fixed head.



4590 vessels (left to right): 25 mL, 50 mL, and 100 mL.

# Series 4590 Ordering Guide

The Order No. for the Base System is: **459\_\_-T-SS-M-115-VS.12-3000-4848**

A composite identification number to be used when ordering a 4590 Series Reactor can be developed by combining individual symbols from the separate sections below. For more information on how to use this ordering guide, [please see page 27](#).

## A Base Model

Model	Size	Vessel Style
4591	25 mL	Moveable Head
4592	50 mL	Moveable Head
4593	100 mL	Moveable Head
4596	25 mL	Fixed Head
4597	50 mL	Fixed Head
4598	100 mL	Fixed Head

## B Pressure / Temperature Options

-No Symbol	3000 psi (207 bar) / 350 °C
-HP	5000 psi (345 bar) / 350 °C
-HP/HT*	5000 psi (345 bar) / 500 °C

\* Fixed Head Only

## C Gasket / Maximum Temperature

-OV	FKM O-ring, 225 °C
-OK	FFKM O-ring, 300 °C
-T	PTFE Flat Gasket, 350 °C
-FG	Flexible Graphite, 500 °C (HP/HT option only)

## D Material of Construction

-SS	T316 Stainless Steel
-MO	Alloy 400*
-IN	Alloy 600
-HB	Alloy B-2 / B-3*
-HC	Alloy C-276
-CS	Alloy 20*
-TI2	Titanium Grade 2*
-TI4	Titanium Grade 4*
-ZR702	Zirconium Grade 702*
-ZR705	Zirconium Grade 705*

\* Maximum temperature and/or pressure limited.  
See [page 10](#) or [24](#) for complete list of available alloys.

## E Stirrer Drive

-M	General Purpose Magnetic
----	--------------------------

## F Mag. Drive Material of Construction

-MOC Symbol	Indicate Material of Construction
-------------	-----------------------------------

## G Electrical Supply

-115	115 VAC
-230	230 VAC

## H Motor Option

-VS .12	Variable Speed, 1/8 hp
-VS .25	Variable Speed, 1/4 hp
-XP .25	Explosion Proof Variable Speed, 1/4 hp
-XP .25X	ATEX Explosion Proof Variable Speed (.18 KW, 0-1300 rpm)
-AM .25	Air Motor, 1/4 hp

## I Pressure Gage

-5000	5000 psi / 345 bar
-3000	3000 psi / 207 bar
-2000	2000 psi / 138 bar
-1000	1000 psi / 69 bar
-600	600 psi / 40 bar
-200	200 psi / 14 bar
-100	100 psi / 7 bar

## J Bottom Drain Valve

-BDV	Bottom Drain Valve (Not available on HP models)
------	---

## K Controller

-4848 (included in base system)	PID Control, Ramp & Soak Programming, Motor Speed Control, and Data logging with Software. (RS-485 to USB cable not included) For use with up to three additional display modules.
-4848B	Same as above but for use with up to six additional display modules.
-A2110E	Motor Controller
-4871	Process Controller (for enhanced control options)

See [Chapter 6](#) for a complete list of controllers and options.

## L 4848 Controller Options

-TDM	Tachometer Display Module
-MCM	Motor Control Module w/Tachometer
-PDM	Pressure Display Module
-HTM	High Temperature Cut Off Module
-ETLM	External Temperature Limit Module
-MTM*	Motor Torque Module
-SVM	Solenoid Valve Module (for cooling control)
-A1925E4	RS-485 to USB Cable for 4848 Controller (required for data logging)
-A1925E6	RS-485 to USB Converter, isolated, 30-ft
-A2208E	RS-485 Daisy Chain for Multiple Controller (must be used with A1925E6)
-A3504HC	SpecView Software Package for 4838/4848

\* The MTM must be installed in conjunction with the MCM.

## M Custom Options (List All Desired)

-GE	Gas Entrainment Stirrer
-BF	Removeable Baffle Set
-XCAD	External Catalyst Addition Device
-SCP	Solids Charging Port (Ball Valve)
-RC	Reflux Condenser
-RTC	Reflux/Take-Off Condenser
-WJ	Welded Jacket
-ABH	Aluminum Block Heater with Cooling Channels

See [Chapter 7](#) for a complete list of optional accessories.

## N Certifications

-ASME	ASME Documentation
-CE	CE Documentation
-P	Parr Certification

## O Spare Parts Kit

-4599M	Spare Parts Kit for 4590 Series
-4599HPHT	Spare Parts Kit for 4590HPHT Series

Please note that all options and combinations are not compatible with all models.

Series Number:

# 5100

Type:  
**Glass or Metal**

Stand:  
**Bench Top**

Mounting Style:  
**Fixed Head**

Vessel Sizes:  
**160 mL - 1.5 L**

Maximum Operating Pressure, MAWP Rating, psi (bar):  
**Glass: 150 (10)**  
**Metal: 1000 (69)**

Maximum Operating Temperature, °C:  
**225**

## Series 5100 Glass Reactors, 160-1500 mL



**5111 Bench Top Reactor, Glass Jacketed Vessel, 1000 mL, Fixed Head.**

### The Parr Series 5100 Low Pressure Glass Reactors offer:

1. A system for running reactions similar to those that have been conducted for many years in the Parr shaker, but which offer stirring for better scalability, higher operating temperatures and pressures, and more extensive reactor controls and instrumentation.
2. Glass Reactors for use at elevated pressures that permit direct observation of mixing action, color changes, or changes of state.
3. Reactors designed for convenient operation at moderate pressure and/or for corrosion resistance.

### Convenient and Easy Sealing with O-rings and Split-Ring Closures

Parr has developed an O-ring and closure system to accommodate the requirements of this unique glass-to-metal seal and support, which is convenient to use. A face seal-type O-ring design is used with the proven and popular

Parr split-ring closure. For this application a special gasket groove was designed to retain the O-ring on the head of the reactor when it is opened. A full range of O-ring materials is available for chemical compatibility with reactants, products and solvents.

The split-ring for the glass vessel is padded with high temperature cushions so the glass vessel does not come in direct contact with the metal split-ring. Six sealing screws are tightened finger tight to develop the seal on the O-ring. The split-ring snaps together with latches to provide a secure and positive closure.

The alternate metal cylinders use a different split-ring designed to handle the higher working pressure of the metal vessels.

### Standard Reactor Fittings

The head of each glass reactor is equipped with:

- Pressure gage, 3-1/2 inch diameter, calibrated 0-200 psi and 0-14 bar
- Gas release valve

## 5100



Split-Ring for Glass Reactors.



Split-Ring for Metal Reactors.

- Gas inlet valve
- Liquid sampling valve
- Internal thermocouple
- Internal cooling loop – standard 300 mL to 1.5 L
- Internal stirrer with magnetic drive
- Heads intended for use with glass cylinders are equipped with spring-loaded relief valves adjustable between 50-150 psi.
- All heads are equipped with a rupture disc rated for 1000 psi.
- Internal fittings are T316 Stainless Steel with optional PTFE coating.

### Materials of Construction

These reactors are a combination of a glass reaction vessel with a metal head, internal stirrer, dip tube, thermowell, cooling loop, and external valves and fittings, or alternately an all metal system.

The standard material of construction for the head is Type 316 Stainless Steel with PTFE coated T316SS internals. As an alternative the head and internal wetted parts can be provided in any of the standard Parr materials of construction. See the 5100 Ordering Guide, [page 63](#).

### Size

Series 5100 Reactors can be easily converted between the 160, 300, 450, and 600 mL sizes by simply changing the cylinders and internal parts. In a similar manner, 1 L and 1.5 L are interchangeable. While the 160-600 mL stand cannot be converted to hold 1 and 1.5 L vessels, the larger stand can be converted to accommodate the 160-600 mL vessels. If you plan to convert at a later time, be sure to order the stand for the largest size you plan to use so the shield and supports will not have to be replaced.

### Heating and Temperature Control

These reactors are available with either jacketed or non-jacketed glass or metal cylinders allowing for heating by either a user supplied circulator or with a removable heating mantle respectively. While we would normally expect glass vessels to be equipped with circulating jackets to maintain their transparent feature, some users may not need to heat their reactions or may prefer to use removable heating mantles when they need to work at elevated temperatures. Although transparency is not an issue with metal vessels, users will generally want to select the same heating method for metal

vessels as they use for glass vessels so they can utilize the same heating and control system for both.

Users who are using a circulating bath that has its own temperature control for use with these reactors will want to order the reactor without a heating mantle and may only need a motor controller for stirring speed to complete the system. Most laboratory circulators should be adequate for these small vessels. Moveable electric heating mantles are available for vessels that do not have attached circulating jackets. These mantles are for use with 115 or 230 VAC.

### 5110 Conversion Sets: Glass to Metal or Metal to Glass

Series 5100 Reactors can be easily converted between glass and metal cylinders. The conversion sets include the cylinder, closure, gage and safety relief devices for the “converted to” system. Sets do not include heater.

#### 5110 & 5120 Conversion Sets

##### Glass to Metal

Catalog Number	Size, mL	Converts From	Converts To
5110A	300	Glass Jacketed	Metal Jacketed
5110B	300	Glass	Metal
5110C	450	Glass Jacketed	Metal Jacketed
5110D	450	Glass	Metal
5110E	600	Glass Jacketed	Metal Jacketed
5110F	600	Glass	Metal
5110M	215	Glass Jacketed	Metal Jacketed
5110N	160	Glass	Metal
5120A	1000	Glass Jacketed	Metal Jacketed
5120B	1000	Glass	Metal
5120C	1500	Glass Jacketed	Metal Jacketed
5120D	1500	Glass	Metal

##### Metal to Glass

Catalog Number	Size, mL	Converts From	Converts To
5110G	300	Metal Jacketed	Glass Jacketed
5110H	300	Metal	Glass
5110I	450	Metal Jacketed	Glass Jacketed
5110J	450	Metal	Glass
5110K	600	Metal Jacketed	Glass Jacketed
5110L	600	Metal	Glass
5110P	215	Metal Jacketed	Glass Jacketed
5110Q	160	Metal	Glass
5120E	1000	Metal Jacketed	Glass Jacketed
5120F	1000	Metal	Glass
5120G	1500	Metal Jacketed	Glass Jacketed
5120H	1500	Metal	Glass

# Series 5100 Glass Reactors, 160-1500 mL

Series 5100 Pressure Reactor System Specifications						
Shaded bar indicates specifications that change within series.						
Model Number	5101	5102	5103	5104	5111	5112
Approximate Volume, mL	300	450	600	160	1000	1500
Maximum Pressure, Glass	150 psi (10 bar)					
Maximum Pressure, Metal	1000 psi (69 bar)					
<b>Maximum Temperature</b>						
with FKM O-ring	225 °C					
with FFKM O-ring, Glass Vessel	225 °C					
with FFKM O-ring, Metal Vessel	300 °C					
<b>Reactor Details</b>						
Mounting Style	Fixed Head					
Stand Type	Bench Top					
Closure	Glass Vessels: 6 Thumb Screws; Metal Vessels: Split-Rings (6 Compression Bolts)					
Valve Connections	1/8" Male NPT					
Magnetic Stirrer, Model No.	A1120HC9					
Maximum Torque	16 Inch-Pounds					
Impeller(s)	1	2	2	1	2	2
Stirrer Motor	1/8 hp variable speed					
Pressure Gage, Size	3.5 inches					
Range, Glass Cylinder	0-200 psi (14 bar)					
Range, Metal Cylinder	0-1000 psi (69 bar)					
Temperature Measurement	Fixed, Type J, Thermocouple					
Cooling Coil	Single Loop Included			None	Single Loop Included	
Heater Style	Mantle					
Heater Power Glass, Watts	510	590	780	400	400	550
Heater Power Metal, Watts	510	590	780	400	450	650
<b>Electrical Supply</b>						
Volts, AC	115 / 230					
Maximum Load, amps, 115 / 230	9 / 5					
<b>Cylinder Dimensions</b>						
I.D. x Depth, inches	2.5 x 4.0	2.5 x 6.0	2.5 x 8.0	2.5 x 2.0	4.0 x 6.0	4.0 x 8.0
Vessel Assembly Weight, Glass, pounds	15	15	16	14	29	28
Vessel Assembly Weight, Metal, pounds	18	19	21	16	33	36
Cylinder Weight, Glass, pounds	0.8	1.1	1.4	0.5	3.0	4.1
Cylinder Weight, Metal, pounds	3.4	4.6	5.9	2.2	8.3	10.8
<b>Reactor/Stand Dimensions</b>						
Width x Depth w/o Controller, inches	17 x 24				21 x 26	
Height, inches	30				33	
Weight, pounds	60	63	66	60	109	113
Spare Parts Kit	5109M				5119M	
Other options available. See Ordering Guide, visit <a href="http://www.parrinst.com">www.parrinst.com</a> , or call for more information. Weights and dimensions are estimated from the base model. Final weights and dimensions will vary based on options selected.						



# Series 5100 Ordering Guide

The Order No. for the Base System is: **51\_\_\_-G-SS-4B-115-VS.12-200**

A composite identification number to be used when ordering a 5100 Series Reactor can be developed by combining individual symbols from the separate sections below. For more information on how to use this ordering guide, [please see page 27](#).

<b>A Base Model</b>	
Model	Size
5101	300 mL
5102	450 mL
5103	600 mL
5104	160 mL (215 mL Glass Jacketed)
5111	1000 mL
5112	1500 mL

<b>B Cylinder Type</b>	
Code	Type
-GJ	Glass Jacketed
-G	Glass
-MJ	Metal Jacketed
-M	Metal

<b>C Gasket</b>	
Code	Type
-OV	FKM O-ring
-OK	FFKM O-ring

<b>D Materials of Construction</b>	
Code	Material
-SS	T316 Stainless Steel
-MO	Alloy 400
-IN	Alloy 600
-HB	Alloy B-2 / B-3
-HC	Alloy C-276
-CS	Alloy 20
-TI2	Titanium Grade 2
-TI4	Titanium Grade 4
-ZR702	Zirconium Grade 702
-ZR705	Zirconium Grade 705

*See page 10 or 24 for complete list of available alloys.*

<b>E Magnetic Stirrer Drive</b>	
Code	Description
-M	General Purpose, 16 in-lb
-FMD1	Footless, General Purpose, 16 in-lb

<b>F Mag. Drive Material of Construction</b>	
MOC Symbol	Indicate Material of Construction

<b>G Electrical Supply</b>	
Code	Voltage
-115	115 VAC
-230	230 VAC

<b>H Motor Option</b>	
Code	Description
-VS .12	Variable Speed, 1/8 hp
-VS .25	Variable Speed, 1/4 hp
-XP .25	Explosion Proof Variable Speed, 1/4 hp
-AM .25	Air Motor, 1/4 hp

<b>I Pressure Gage</b>	
Code	Pressure
-200	200 psi / 14 bar
-100	100 psi / 7 bar
-1000	1000 psi / 69 bar (Metal Vessels Only)

<b>J Heater</b>	
Code	Description
-MH	Mantle (Non-Jacketed Vessels Only)
-NH	No Heater

<b>K Controller</b>	
Code	Description
-4848	PID Control, Ramp & Soak Programming, Motor Speed Control, and Data logging with Software. (RS-485 to USB cable not included) For use with up to three additional display modules.
-4848B	Same as 4848 but with up to six additional modules
-A2110E	Motor Controller
-4871	Process Controller (for enhanced control options)

*See Chapter 6 for a complete list of controllers and options.*

<b>L 4848 Controller Options</b>	
Code	Description
-TDM	Tachometer Display Module
-MCM	Motor Control Module w/Tachometer
-PDM	Pressure Display Module
-HTM	High Temperature Cut Off Module
-ETLM	External Temperature Limit Module
-MTM*	Motor Torque Module
-SVM	Solenoid Valve Module (for cooling control)
-A1925E4	RS-485 to USB Cable for 4848 Controller (required for data logging)
-A1925E6	RS-485 to USB Converter, isolated, 30-ft
-A2208E	RS-485 Daisy Chain for Multiple Controller (must be used with A1925E6)
-A3504HC	SpecView Software Package for 4838/4848

*\* The MTM must be installed in conjunction with the MCM.*

<b>M Custom Options (List All Desired)</b>	
Code	Description
-PS	Paddle Stirrer, 300 mL and Larger
-GE	Gas Entrainment Stirrer
-XCAD	External Catalyst Addition Device
-SCP	Solids Charging Port (Ball Valve)
-RC	Reflux Condenser
-RTC	Reflux/Take-Off Condenser

*See Chapter 7 for a complete list of optional accessories.*

<b>N Certifications</b>	
Code	Description
-ASME	ASME Documentation
-CE	CE Documentation
-P	Parr Certification

<b>O Spare Parts Kit</b>	
Code	Description
-5109M	Spare Parts Kit for Models 5101, 5102, 5103, 5104
-5119M	Spare Parts Kit for Models 5111 and 5112

*Please note that all options and combinations are not compatible with all models.*

Series Number:

# 5500

Type:  
**High Pressure, Compact**

Stand:  
**Bench Top**

Mounting Style:  
**Moveable**

Vessel Sizes, mL:  
**25-600**

Standard Pressure  
MAWP, psi (bar):  
**3000 (207)**

Maximum Operating  
Temp., °C:  
**225 w/ FKM O-ring**  
**300 w/ FFKM O-ring**  
**350 w/ PTFE Flat Gasket**

## Series 5500 HP Compact Reactors, 25-600 mL

### Familiar Parr Designs

All of the safety, convenience and reliability features which have been the hallmark of Parr pressure reaction equipment for more than 50 years have been incorporated into a new line of high pressure, compact laboratory reactors.

**The Series 5500 Compact Reactors** are based upon our popular micro and mini, Series 4590 & 4560 Reactors. There are several differences between these new reactors and their original counterparts. Primarily, these are:

- A smaller, more compact magnetic drive is installed.
- A smaller, more compact variable speed stirrer motor.
- The larger support stand, overarm and motor have been eliminated.
- An Aluminum Block Heater also serves as the support stand.

As a result of these changes, we are able to offer these reactors to users who do not require the wide variety of options and expandability provided by our Series 4560 and 4590 Reactors at a significantly lower cost. These designs will be welcomed by not only scientists with limited space or budgets, but also by those building multiple reactor installations for combinatorial chemistry or high throughput investigations.

**The reaction vessels used in these reactors** are identical to the ones furnished in the Series 4590 Micro and Series 4560 Mini Reactors and use the popular Parr split ring closure. These vessels are rated for a maximum working pressure of 3000 psi. The maximum operating temperature is dependent upon the seal selected, PTFE gasket for up to 350 °C; with FKM O-ring to 225 °C or FFKM O-ring to 300 °C.

The 25, 50, and 100 mL reactors are equipped with gas inlet and outlet valve, a liquid sampling valve, pressure gage, safety rupture disc, and internal thermocouple in addition to the internal stirrer. The 300, 450, and 600 mL reactors provide an optional internal cooling loop in addition to these fittings. In addition to the standard Type 316 Stainless Steel, the vessels for these reactors can also be constructed from any of the standard Parr materials of construction.

These vessels are designed, built and can be certified to the ASME Pressure Vessel Code, European Community

P.E.D. and other appropriate local codes. Electrical safety is certified by CSA and the EC-CE mark.

### New Magnetic Drive

To take advantage of the new technology available in magnets today, Parr has designed a new compact, magnetically-coupled stirrer drive especially for these smaller vessels. Tests show that this new drive is sufficient to stir reaction mixtures with viscosities up to 10,000 centipoise in a 600 mL reaction vessel.

### Variable Speed Motor

A 1/17 hp variable speed motor provides stirring speeds adjustable from 0 to 1700 rpm. An optional tachometer pickup provides a signal to the optional tachometer display module which can be installed in the 4848 Controller.

### New Heater / Reactor Support

A new heater that also serves as the vessel support has been designed for these reactors. This is an aluminum block style heater for excellent thermal uniformity. The cartridge heaters used in this heating block are easily replaced if required. A stainless steel heat shield is provided around the heating block. This style of heater/reactor support provides a very small footprint, ideal for limited bench space.

### Model 4848 Temperature Controller

The Series 4848 Controller used with the standard Parr line of medium and high pressure reactors is also furnished for use with these reactors. The 4848 offers the user options for redundant temperature sensor and alarm, digital



Parr Series 5500 HPCL Reactor and a 4848 Reactor Controller shown with optional Expansion Modules.

## 5500

Series 5500 Pressure Reactor System Specifications								
Shaded bar indicates specifications that change within series.								
Model Number	5511	5512	5513	5521	5522	5523	5524	5525
Sizes, mL	25	50	100	300	450	600	160	100
Maximum Pressure	3000 psi (207 bar, 200 bar for CE orders)							
<b>Maximum Temperature</b>								
with FKM O-ring	225 °C							
with FFKM O-ring	300 °C							
with PTFE Flat Gasket	350 °C							
<b>Reactor Details</b>								
Mounting Style	Moveable							
Stand Type	Compact Bench Top							
Closure	Split-Ring (6 Compression Bolts for Flat Gasket, No Compression Bolts for O-ring)							
Valve Connections	1/8" Male NPT							
Maximum Torque	2.5 Inch-Pounds (0.28 Nm)							
Impeller(s), 4-blade	1 (0.81" dia.)		1 (0.81" dia.)		2 (1.38" dia.)		1 (0.81" dia.)	
Stirrer Motor, Variable Speed	1/17 hp							
Pressure Gage, Size	3.5 inches							
Range	0-3000 psi (207 bar)							
Temperature Measurement	Fixed Thermocouple							
Cooling Coil	Coldfinger (optional)			Standard Single Loop			Spiral (optional)	
Bottom Drain Valve	N/A							
Heater Style	Aluminum Block (External Cooling optional)							
Heater Power, Watts	700	1000	700	1000	700	1000	700	700
<b>Electrical Supply</b>								
Volts, AC	115 / 230							
Maximum Load, amps, 115 / 230	8 / 4	10 / 5	8 / 4	10 / 5	8 / 4	10 / 5	8 / 4	8 / 4
<b>Cylinder Dimensions</b>								
I.D. x Depth, inches	1.0 x 2.0	1.3 x 2.25	1.3 x 4.5	2.5 x 4.0	2.5 x 6.0	2.5 x 8.0	2.5 x 2.0	2.0 x 2.0
Vessel Assembly Weight, pounds	17	17	18	17	18	20	16	16
Cylinder Weight, pounds	3.5	3.1	4.2	3.7	4.9	6.2	2.4	3.3
<b>Reactor/Stand Dimensions</b>								
Width x Depth w/o Controller, inches	8.3 x 9.5							
Height, inches	23	23	25	23	25	27	23	23
Weight, pounds	25	25	25	26	28	30	25	25
Spare Parts Kit	5509M							
Other options available. See Ordering Guide, visit <a href="http://www.parrinst.com">www.parrinst.com</a> , or call for more information. Weights and dimensions are estimated from the base model. Final weights and dimensions will vary based on options selected.								

pressure readout, stirring speed display or control, motor load, and bi-directional digital communication (RS-485).

### Alternate Controllers Available

A single 4871 Process Controller can control up to eight high pressure, compact laboratory reactors.

### Options

As shown in the ordering guide, a variety of options are available for these Series 5500 Reactors. In addition to the

options described here, there are a number of additional accessories such as glass or PTFE liners, special stirrers, gages, gas and liquid feed systems, custom valves, etc., as described in the Options Section of the Ordering Guide.

The Series 5500 Reactors have been designed and packaged to provide the basic functions of a small laboratory reactor and not all of the options available for the more versatile Series 4560 and 4590 Reactors can be incorporated into these units.

# Series 5500 Ordering Guide

The Order No. for the Base System is: **55\_\_\_-T-SS-115-VS-M-3000-4848**

A composite identification number to be used when ordering a 5500 Series Reactor can be developed by combining individual symbols from the separate sections below. For more information on how to use this ordering guide, [please see page 27](#).

<b>A Base Model</b>		
Model No.	Size	Cylinder, I.D.
5511	25 mL	1.0-inch
5512	50 mL	1.3-inch
5513	100 mL	1.3-inch
5521	300 mL	2.5-inch
5522	450 mL	2.5-inch
5523	600 mL	2.5-inch
5524	160 mL	2.5-inch
5525	100 mL	2.0-inch

<b>B Gasket / Maximum Temperature</b>	
-OV	FKM O-ring, 225 °C
-OK	FFKM O-ring, 300 °C
-T	PTFE Flat Gasket, 350 °C

<b>C Materials of Construction (MOC)</b>	
-SS	T316 Stainless Steel
-MO	Alloy 400
-IN	Alloy 600
-HB	Alloy B-2 / B-3
-HC	Alloy C-276
-CS	Alloy 20
-Ti2	Titanium Grade 2
-Ti4	Titanium Grade 4
-ZR702	Zirconium Grade 702
-ZR705	Zirconium Grade 705

See [page 10](#) or [24](#) for complete list of available alloys.

<b>D Electrical Supply</b>	
-115	115 VAC
-230	230 VAC

<b>E Motor</b>	
-VS	1/17 HP Variable Speed

<b>F Magnetic Stirrer Drive</b>	
-M	General Purpose Magnetic

<b>G Mag. Drive Materials of Construction</b>	
-MOC Symbol	Indicate Material of Construction

<b>H Pressure Gage</b>	
-3000	3000 psi / 207 bar
-2000	2000 psi / 138 bar
-1000	1000 psi / 69 bar
-600	600 psi / 40 bar
-200	200 psi / 14 bar
-100	100 psi / 7 bar

<b>I Controller</b>	
-4848 (included in base system)	PID Control, Ramp & Soak Programming, Motor Speed Control, and Data logging with Software. (RS-485 to USB cable not included) For use with up to three additional display modules.
-4848B	Same as above but for use with up to six additional display modules.
-A2110E	Motor Controller
-4871	Process Controller (for enhanced control options)

See [Chapter 6](#) for a complete list of controllers and options.

<b>J 4848 Controller Options</b>	
-TDM	Tachometer Display Module
-MCM	Motor Control Module w/Tachometer
-PDM	Pressure Display Module
-HTM	High Temperature Cut Off Module
-ETLM	External Temperature Limit Module
-MTM*	Motor Torque Module
-SVM	Solenoid Valve Module (for cooling control)
-A1925E4	RS-485 to USB Cable for 4848 Controller (required for data logging)
-A1925E6	RS-485 to USB Converter, isolated, 30-ft
-A2208E	RS-485 Daisy Chain for Multiple Controller (must be used with A1925E6)
-A3504HC	SpecView Software Package for 4838/4848

\* The MTM must be installed in conjunction with the MCM.

<b>K Custom Options (List All Desired)</b>	
-GE	Gas Entrainment Stirrer
-BF	Removeable Baffle Set
-CAD	Internal Catalyst Addition Device
-XCAD	External Catalyst Addition Device
-SCP	Solids Charging Port (Ball Valve)
-RC	Reflux Condenser
-RTC	Reflux/Take-Off Condenser

See [Chapter 7](#) for a complete list of optional accessories.

<b>L Certifications</b>	
-ASME	ASME Documentation
-CE	CE Documentation
-P	Parr Certification

<b>M Spare Parts Kit</b>	
-5509M	Spare Parts Kit for 5500 Series

Please note that all options and combinations are not compatible with all models.

# Multi Reactor Systems **Chapter 3**



**Inside this chapter you will find:**

[5000 Multiple Reactor System \(MRS\)](#)

[2500 Micro Batch Reactor System](#)

[Parallel Reactor Systems](#)

Series Number:

# 5000

Type:  
**Multiple Vessel**

Stand:  
**Bench Top**

Vessel Mounting:  
**Moveable**

Vessel Sizes, mL:  
**45 and 75**

Standard Pressure  
MAWP Rating, psi (bar):  
**3000 (200)**

Standard Maximum  
Operating Temp., °C:  
**225 w/ FKM O-ring**  
**300 w/ FFKM O-ring**  
**300 w/ PTFE Flat Gasket**

## 5000 Multiple Reactor System (MRS)

### The Parr Series 5000 Multiple Reactor System

has been designed to provide an integrated system for running multiple reactions simultaneously and applying the principles of high throughput experimentation to reactions conducted at elevated temperatures and pressures.

The principal features of the 5000 System include:

- Six reactors with internal stirring.
- Operating pressures to 3000 psi.
- Operating temperatures to 300 °C.
- Individual temperature control.
- Continuous individual pressure monitoring.
- Computer control and data logging.
- Manifold system for rapid turn around and to allow two different input gases.
- Volumes and reactor geometry designed for three phase reactions.
- Flexible Control Software.

### Stirred Batch Reaction Vessel

This multiple reaction system has been designed around a vessel with 75 mL total volume. This will accommodate between 15 mL and 40 mL of liquid reactants which is close to the minimum volume appropriate for heterogeneous catalytic reactions.

The vessel valves and accessories are designed for maximum operating pressures up to 3000 psi at operating temperatures up to 300 °C. A system with 45 mL vessels is also available.

### Stirring System

All six vessels are stirred with a single magnetic stirrer system specifically designed and built for this application. The magnetic drives and fields are focused on the stirrer bars within each vessel. High strength compact magnets are used to provide coupling forces which will operate through the heaters and vessels. The stirring speed of the stirrer bar is variable from 0-1200 rpm. All vessels will have the same stirring speed during a single run of the apparatus. This arrangement ensures that the difference in reaction rates between vessels run in parallel are due to set conditions other than variations in stirrer speed.

### Heaters

The external heaters surround the vessel walls for rapid and uniform heating and temperature control. Each vessel is individually temperature controlled. The 250-watt heater used on each vessel produces heating rates up to 15 °C per minute. An optional reactor cooling support rack is available for air-cooling.



**Model 5000 Multiple Reactor System, six 75 mL Vessels with Flat Gaskets and Head-Mounted Valves, shown with included 4871 Process Controller.**

Series 5000 Pressure Reactor System Specifications				
Shaded bar indicates specifications that change within series.				
Model Number	5000			
Approximate Sizes, mL	45		75	
No. of Reaction Vessels	6			
Maximum Pressure (MAWP)	3000 psi (200 bar)			
Maximum Temperature				
with FKM O-ring	225 °C			
with FFKM O-ring	300 °C			
with PTFE Flat Gasket	300 °C			
Closure				
with O-ring	Screw Cap			
with Flat Gasket	Screw Cap (6 Compression Bolts)			
Material of Construction	T316SS			
Process Controller	Model 4871			
Analog Inputs	6 Temperature			
	6 Pressure			
	1 Motor Speed			
Analog Outputs	1 Stirrer Speed (Optional)			
Digital Outputs	6 PID Temperature Control			
Temperature Measurement	6 Thermowells			
Heater Style	6 Band Heaters, Aluminum Block			
Heater Power, Watts	250W Per Station, 1500W Total			
External Thermocouple	Optional			
Stirrer Motor Type	Manual or Computer Controlled			
Stirrer Style	PTFE- or Glass-Coated Magnetic Stirrer Bar			
Electrical Supply				
Volts, AC	115 / 230			
Maximum Load, amps, 115 / 230	15 / 7.5			
Vessel Dimensions				
Inside Diameter, inches	1.18		1.50	
Inside Depth, inches	2.69 Flat Gasket, 2.50 O-ring			
Weight of Vessel, pounds	3 (w/ Panel-Mounted Valves)		6 (w/ Head-Mounted Valves)	
Dimensions	Width, in.	Depth, in.	Height, in.	Weight, lbs.
Heater	25.75	9.25	2.875	31
Stirrer	28	9.5	7.625	12
4871 Controller	13	11	15	14
Manifold, Remote	26.5	9.0	15	36
Manifold, Head Mount	26.5	9.0	15	18
Spare Parts Kit	5009M			
Other options available. See Ordering Guide, visit <a href="http://www.parrinst.com">www.parrinst.com</a> , or call for more information.				

### Operating Modes

The Series 5000 Multiple Reaction System provides an apparatus for running up to six reactions in parallel to build a database for comparing and optimizing operating conditions. The user can design experiments to:

- Run all reactions at the same temperature and pressure while varying catalyst loading or reactant concentrations to optimize these parameters.
- Run all reactors with identical loads varying pressures at a common temperature to study the effect of pressure on reaction rates.
- Run individual reactors with individual loading and temperature and pressure to screen multiple options for activity.

A comparison of the plots of pressure drop versus time within the reactors running under parallel conditions will usually be the most useful means of measuring reaction rates and comparing operating conditions. The internal thermocouple also provides a means of detecting temperature changes due to exothermic reactions.

### Reactor Options

As Parr customers have come to expect with our line of laboratory pressure reactor equipment, these reactors are offered with a number of options which permit the user to configure the system to their reactions and intended operating conditions. These options include:

**O-ring or Flat Gasket Seals.** Vessels with O-ring seals are closed by simply tightening the screw cap down hand tight. The maximum operating temperature will depend upon the O-ring material. When equipped with FKM (Viton®) O-rings operating temperatures up to 225 °C are permitted. By substituting FFKM (Kalrez®) O-rings this limit can be raised to 300 °C. Careful consideration of chemical compatibility must also be given when selecting O-ring materials. PTFE gaskets can be used to temperatures up to 300 °C and offer virtually universal chemical compatibility. Six compression bolts are used to develop the sealing forces on the PTFE gaskets in this design.

## 5000 Multiple Reactor System (MRS)

**Head Configuration.** Each reaction vessel is equipped with an inlet valve, exhaust valve, safety rupture disc, and pressure transducer in addition to an internal thermocouple. Vessels can be modified to include a dip tube for liquid sampling or a cold finger for cooling. The user can choose to have the valves, transducer and rupture disc mounted on a multi-port adapter connected directly to the vessel head, or remotely mounted on the back panel.

- **Head Mounted.** The head mounted design makes it possible to remove the pressurized vessels from the heater/stirrer assembly or to refill the vessels in a remote location. PEEK flexible tubing with a quick slip connector is provided for each vessel for inlet of gas. Tubing is easily removed after gas fill.
- **Panel Mounted.** The remote panel mounted arrangement connects all the pressure inlets/outlets to each vessel with a single PTFE lined stainless tubing. Alternate stainless steel tubing is offered if required. In the panel mount valve configuration the gas inlet tubing generally remains attached to the vessels during operation.

**Materials of Construction.** Type 316 Stainless Steel is the standard material of construction for both the vessel with its wetted parts and the valve and head fittings exposed to vapors. For investigators working with systems containing strong mineral acids or other more corrosive systems these vessels can be made of most of the Parr standard materials of construction.

**Stirrer Configuration.** Stirring is accomplished by use of either PTFE coated or glass coated magnetic stirrer bars.

**Thermocouple Configuration.** Thermocouples are mounted inside the vessel for the best temperature monitoring and control. The thermocouples

are protected by stainless steel sheaths which are inserted into a protective thermowell. These thermowells make it easy to install and remove thermocouples from the vessels, and also provide additional chemical and mechanical protection for the thermocouple.

We also offer an external thermocouple option with the thermocouples positioned in contact with each cylinder wall.

**Gas Manifold.** The brass gas inlet manifold is designed to handle both a purge gas, usually nitrogen, and a reactant gas, usually hydrogen. This can be set up to automatically fill each vessel to the same initial pressure or to manually fill each vessel to a unique operating pressure. This gas manifold can also be supplied in T316SS to meet more corrosive requirements.

**Gas burettes.** For applications where gas consumption measurement is important, optional high pressure gas burettes can be provided (see photo on this page). These burettes allow monitoring/calculation of the number of moles of gas consumed during a reaction. A complete description and list of available volumes and delivery pressure ranges can be found on [page 126](#) of this catalog (or at <https://www.parrinst.com/hpb>).

### 4871 Process Controller

The Series 5000 Multiple Reaction System is controlled by a dedicated Parr 4871 Process Controller. A detailed description of this controller is found in [Chapter 6](#) of this catalog, [page 109](#).

For this application the controller is set up to provide:

- Temperature monitoring and PID control of each individual reactor
- Pressure monitoring of each individual reactor
- Data logging of temperature and pressure in each reactor
- Control and logging of the common stirring speed of the reactors.

The controller provides Ramp & Soak programming for individual reaction vessels, digital inputs and outputs for interlocks, alarms or other safety features, and additional analog and digital inputs and outputs to control flow meters or other accessories which might be added at some future date. The user's control station is a PC running any current Windows operating system. A simplified graphical user interface has been designed for the control and monitoring of the Series 5000 Multiple Reaction System. The PC is used strictly as the user interface and data logging module. All control actions are generated in the 4871 Process Controller (not the PC).



MRS with individually controlled Gas Burettes.



# Series 5000 Ordering Guide

The Order No. for the Base System is: **5000(45)-T-SS-115-P-MV-2000-MB-CC**

A composite identification number to be used when ordering a 5000 Series Reactor can be developed by combining individual symbols from the separate sections below. For more information on how to use this ordering guide, [please see page 27](#).

A Base Model	
Model No.	Size
5000	45 or 75 mL

B Gasket / Maximum Temperature	
-OV	FKM O-ring, 225 °C
-OK	FFKM O-ring, 300 °C
-T	PTFE Flat Gasket, 300 °C

C Materials of Construction	
-SS	T316 Stainless Steel
-MO	Alloy 400
-IN	Alloy 600
-HB	Alloy B-2 / B-3
-HC	Alloy C-276
-CS	Alloy 20
-TI2	Titanium Grade 2
-TI4	Titanium Grade 4
-ZR702	Zirconium Grade 702
-ZR705	Zirconium Grade 705

See [page 10](#) or [page 24](#) for complete list of available alloys.

D Electrical Supply	
-115	115 VAC
-230	230 VAC

E Thermocouple	
-No Symbol	Type J (Standard)
-K	Type K

F Valve Mounting	
-H	Head Mount w/ PEEK Tubing
-P	Remote Panel Mount w/ PTFE Lined SS Hoses

G Inlet Valve	
-AC	Automatic Check Valve
-MV	Manual Valve

H Transducer Range	
-1000	0-1000 psi
-2000	0-2000 psi
-3000	0-3000 psi

I Stirrer Type	
-MB	Magnetic Bar Stirrer, PTFE
-GB	Magnetic Bar Stirrer, Glass

J Stirring Control	
-M	Manual
-CC	Computer Controlled
-RPM	Digital RPM Display

K Certifications	
-No Symbol	No Certification
-ASME	ASME Certification
-PED	PED Certification
-P	Parr Certification

L Options	
-SV*	Dip Tube with Sampling Valve
-CF*	Cold Finger
-MPG	Manifold Pressure Gage
-FMH	Flexible SS Hoses
-E-TC	External Thermocouple
-R-TC	Redundant Thermocouple
-RCS	Reactor Cooling Support
-2280	Gas Burettes ( <a href="#">see page 126</a> )

\* Dip Tubes & Cold Fingers cannot be installed at the same time.

M Spare Parts	
-5009M	Spare Parts Kit for 5000 Series
-5050	Replacement Vessel, T316SS, 75 mL, including head, cylinder, screw cap and thermowell
-5051	Replacement Vessel, T316SS, 45 mL, including head, cylinder, screw cap and thermowell

Other Available Options	
Glass Liner	
PTFE Liner	

Parr also designs and builds a wide range of multiple reactor systems with overhead magnetic drive stirrers. Many of these multiple reactor systems have been based upon our Series 4590 Micro Reactors, Series 4560 Mini Reactors, and our Series 5500 High Pressure Compact Reactors. We have also supplied multiple reactor systems based on our largest 4555 Stirred Reactor Series. Please see [page 74](#) of this catalog for examples. Contact our Customer Service Department for details and proposals for custom systems.

Series Number:

# 2500

Type:  
**Micro Batch**

Stand:  
**Bench Top**

Vessel Mounting:  
**Moveable**

Vessel Sizes, mL:  
**5 and 10**

Maximum Operational  
Pressure, psi (bar):  
**3000 (200) Standard**

Standard Maximum  
Operating Temp., °C:

**150 w/ EP O-ring**  
**225 w/ FKM O-ring**  
**275 w/ FFKM O-ring**  
**300 w/ Carbon-Filled  
PTFE Flat Gasket**

## Series 2500 Micro Batch Reactor System

The **2500 Micro Batch Reactor System** is our smallest ever family of stirred reactors, available in a number of configurations. With reactor volumes of 5 mL or 10 mL, independent reactor gas filling, PID temperature control, and a choice of two closure styles, the flexibility of the MBS 2500 is sure to bring value to your small volume, high pressure project.

Based on the popular Parr MRS 5000, the MBS 2500 offers even smaller volume options, a smaller footprint, a stand-alone controller and data logging system, and a lower per reactor price.

### Features of the Micro Batch System 2500 include:

- Three reactors with 5 mL or 10 mL volume, available in stainless steel, high-nickel alloys, titanium, zirconium, and other exotic materials
- Small 12" x 12" (30.5 cm x 30.5 cm) footprint, with remotely located 4848-based controller for temperature/stirring control and pressure display.
- Standard 3000 psi (207 bar, 200 bar for CE) at 300 °C rating in T316 Stainless Steel
- Trusted Parr seal geometry employing either a captive PTFE flat gasket and screw cap with compression bolts, or a self-sealing O-ring with tool-free screw cap closure



**Parr Model 2500 Micro Batch Reactor alongside the 4848 Micro Batch System Controller**

- Standard head fittings to include safety rupture disc, pressure transducer, inlet/vent valve, and internal thermocouple
- 3-valve inlet manifold for control of gas addition
- Common aluminum block heater with PID control
- Individual reactor temperature monitoring
- Individual reactor pressure monitoring
- Common stirring speed via individual PTFE- or Pyrex-encapsulated stir bars

# Series 2500 Ordering Guide

The Order No. for the Base System is:

**2500(5)-T-SS-115-RCS-MPG-3000-MCM-4848MBSC**

Series 2500 Micro Batch System Specifications				
Shaded bar indicates specifications that change within series.				
Model Number	2500			
Sizes, mL	5	10		
No. of Reaction Vessels	3			
Maximum Pressure	3000 psi (207 bar, 200 bar for CE)			
Maximum Temperature (Internal)				
with EP O-ring	150 °C			
with FKM O-ring	225 °C			
with FFKM O-ring	275 °C			
with Carbon-Filled PTFE Flat Gasket	300 °C			
Closure				
with O-ring	Screw Cap			
with Flat Gasket	Screw Cap (6 Compression Bolts)			
Material of Construction	T316SS			
Controller	Model 4848MBSC			
Analog Inputs	4 Temperature (3 Vessels, 1 Heater Block)			
	3 Pressure			
	1 Motor Speed			
Analog Outputs	1 Stirrer Speed			
Digital Outputs	1 PID Temperature Control			
Temperature Measurement	Individual Thermowell inside each vessel			
Heater Style	Aluminum Block			
Heater Power, Watts	450W			
Block Mounted Thermocouple	Included			
Stirrer Motor Type	Manual or Computer Controlled			
Stirrer Style	PTFE- or Pyrex-encapsulated Magnetic Stirrer Bars			
Electrical Supply				
Volts, AC	115 / 230			
Maximum Load, amps, 115 / 230	4.6 / 2.3			
Vessel Dimensions				
Inside Diameter, inches	0.62	0.80		
Inside Diameter, inches	1.06	1.22		
Weight of Vessel, pounds	3 (w/ Panel-mounted Valves)			
Dimensions	Width, in.	Depth, in.	Height, in.	Weight, lbs.
Main Unit	8	10.5	22	41
4848MBSC Controller	13.5	11	10	14
Spare Parts Kit	2509M			
Other options available. See Ordering Guide, visit <a href="http://www.parrinst.com">www.parrinst.com</a> , or call for more information.				

## A Base Model

Model No.	Size
2500	5 or 10 mL

## B Gasket / Maximum Temperature

-OV	FKM O-ring, 225 °C
-OK	FFKM O-ring, 275 °C
-T	Carbon-filled PTFE Flat Gasket, 300 °C
-EP	EP O-ring, 150 °C

## C Materials of Construction

-SS	T316 Stainless Steel
-MO	Alloy 400
-IN	Alloy 600
-HB	Alloy B-2 / B-3
-HC	Alloy C-276
-CS	Alloy 20
-Ti2	Titanium Grade 2
-Ti4	Titanium Grade 4
-ZR702	Zirconium Grade 702
-ZR705	Zirconium Grade 705

See page 10 or 24 for complete list of available alloys.

## D Electrical Supply

-115	115 VAC
-230	230 VAC

## E Thermocouple

-No Symbol	Type J (Standard)
-K	Type K

## F Transducer Range

-1000	0-1000 psi
-2000	0-2000 psi
-3000	0-3000 psi

## G Stirrer Type

-MB	Magnetic Bar Stirrer, PTFE
-GB	Magnetic Bar Stirrer, Glass

## H Certifications

-No Symbol	No Certification
-PED	PED Certification
-P	Parr Certification

## I Options

-PTFE	PTFE Liner
-------	------------

## J Spare Parts

-2509M	Spare Parts Kit with three Inconel rupture discs, 18 gaskets, and lube
-2550	Replacement vessel, T316SS, 10 mL, including head, cylinder, and screw cap
-2551	Replacement vessel, T316SS, 5 mL, including head, cylinder, and screw cap

# Parallel Reactor Systems

**Parr designs and builds** custom parallel reactor and multiple reactor systems for use in high-throughput screening, combinatorial chemistry, corrosion testing, and catalyst testing.

These systems are based on our wide range of reactor systems and feature overhead magnetic drive stirrers. Contact our Customer Service Department for details and proposals for custom parallel reactor systems.



## Sixteen Reactor Parallel System

This system is a combination of sixteen standard 4560 Mini Reactors with heaters, valves, pressure gages and rupture disc assemblies and two 4871 Process Controllers with sixteen 4875 Power Controllers. It allows the user to run multiple reactions simultaneously, applying the principles of high-throughput experimentation. Individual variables that can be controlled are gas mixtures, liquids, catalysts or other solids, stirring speed, temperature, pressure and time.

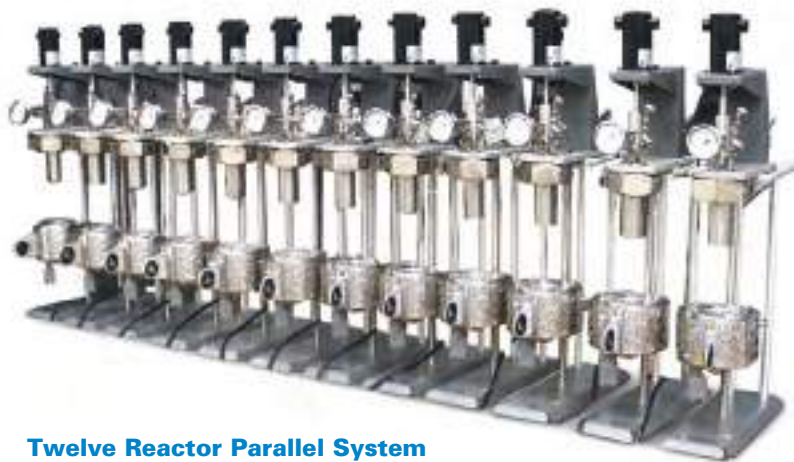

## Twelve Reactor Parallel System

This system makes use of the lower cost 5500 High Pressure Compact Lab Reactors that feature a modified stand, aluminum block heaters, removable vessels and a standard gage block assembly. A control system (not pictured) automates the process, monitors the parameters and collects the data.



## Five Reactor Parallel System

This Parallel Reactor System incorporates five 160 mL, 4560 Series Stirred Mini Reactors rated for use at 350 °C and 3000 psig / 200 bar. Each of the reactors has a dedicated high pressure (5000 psig / 345 bar) 100 mL general purpose vessel associated with it serving as a reactant gas feed reservoir. These feed vessels are located above and immediately behind the main reactors and are each equipped with a dedicated pressure transducer, thermocouple and a constant pressure regulator. The regulator maintains the downstream reactor at a constant pressure while the pressure transducer/thermocouple combination allows the process controller to accurately monitor and record the real-time consumption of reactant gas. This system would normally be used to study various aspects of hydrogenation or carbonylation reactions. The 4871 Process Controller also controls and records the reactor temperature, stirring speed and monitors the reaction pressure. The compact reactor system stand incorporates not only reactant gas feed and vent/ purge manifolds but cooling water feed and drain manifolds to simplify the installation and hook up.



### Three Reactor Parallel System

This system incorporates three 1.8 L 4570 Series High Pressure/High Temperature reactors rated for use at 5000 psi (345 bar) at 500 °C. The reactors in this system are manufactured of Alloy C-276 and are equipped with internal coupon holders to facilitate study of corrosion processes in harsh environments. This particular application does not require precisely controlled gas delivery, so Individual gas feed vessels are not present. However, gas supply and gas vent manifolds are provided. A 4871 Process Controller is also included (not shown).



### Four Reactor Parallel System on Moveable cart

This system consists of three 160 mL and one 450 mL 4560 Series Reactors rated for use at 3000 psi (200 bar) at 350 °C. This configuration allows both high throughput screening and scale-up, if desired. Gas supply and vent manifolds for the entire system and pressure control for the larger reactor are provided. Reactor temperatures and stirring speed are controlled by four 4848 Reactor controllers (not shown).

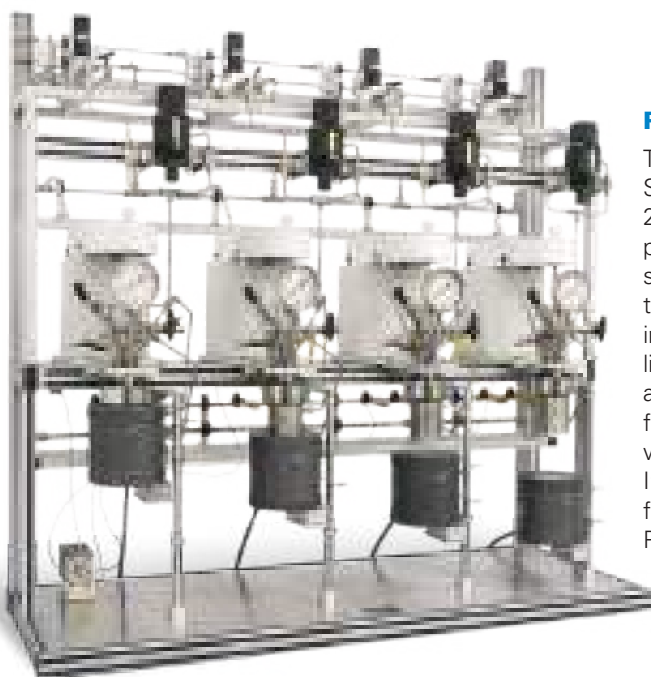

### Four Reactor Benchtop Parallel System

This system combines four 300 mL, 4560 Series Mini Bench Top Reactors dual rated for 2900 psi (200 bar) at up to 350 °C and 2000 psi (137 bar) at 500°C. This multiple reactor system was designed for hydrogenation testing in the petroleum industry and includes individually controlled gas feed lines, a liquid pump to sequentially fill the reactors, and an automated vent system. Manifolds for gas supply & vent, as well as cooling water supply and drain are also included. Independent temperature and motor control for each reactor is provided by a 4871 Process Controller (not shown).

*Parallel systems continued next page >*

# Parallel Reactor Systems, continued

< Parallel systems continued from previous page



## Six Reactor Parallel System with Automatic Sampling System

This system includes six 25 mL, 4590 Series Stirred Micro Reactors rated for use up to 3000 psi (200 bar) at 350 °C. Gas supply and vent manifolds are provided, as well as manifolds to deliver and drain cooling water to/from either the internal cold finger or the external aluminum block heaters with cooling channels. Control is provided by a 4871 Process Controller.

Note, an automated liquid sampling system installed on the far left reactor allows the sequential collection of several ~1 mL liquid samples under full reactor operating pressure. The system automatically clears the lines between samples.

For more information on automated liquid sampling, please see the 4878 Automated Liquid Sampler System on [page 130](#).

# Tubular Reactor Systems **Chapter 4**

**Inside this chapter you will find:**

[5400 Tubular Reactor System](#)

[Fluidized Bed Reactor Systems](#)



Series Number:

# 5400

Type:  
**Bench Top or  
Floor Stand**

Vessel Sizes, mL:  
**5 mL - 1000 mL**

Standard Pressure  
MAWP Rating, psi (bar):  
**1500 (100)  
3000 (207)  
4500 (300)**

Maximum Operating  
Temperature, °C:  
**350 or 550**

## Series 5400 Continuous Flow Tubular Reactor Systems

Tubular reactors are used in a continuous flow mode with reagents flowing in and products being removed. They can be the simplest of all reactor designs. Tubular reactors are often referred to by a variety of names:

- Pipe reactors
- Packed-bed reactors
- Fixed-bed reactors
- Trickle-bed reactors
- Bubble-column reactors
- Ebullating-bed reactors

Single-phase flow in a tubular reactor can be upward or downward. Two-phase flow can be co-current up-flow, counter-current (liquid down, gas up) or, most commonly, co-current down-flow.

Tubular reactors can have a single wall and be heated with an external electric furnace or they can be jacketed for heating or cooling with a circulating heat transfer fluid. External furnaces are typically rigid, split-tube heaters. Tubular reactors are used in a variety of industries:

- Petroleum
- Petrochemical
- Polymer
- Pharmaceutical
- Waste Treatment
- Specialty Chemical
- Alternative Energy

Tubular reactors are used in a variety of applications, including:

- Carbonylation
- Dehydrogenation
- Hydrogenation
- Hydrocracking
- Hydroformulation
- Oxidative decomposition
- Partial oxidation
- Polymerization
- Reforming

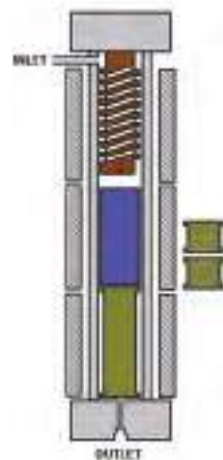

Tubular reactors may be empty for homogenous reactions or packed with catalyst or other solid particles for heterogeneous reactions. Packed reactors require upper and lower supports to hold particles in place. Upper packing often includes inert material to serve as a pre-heat section. Pre-heating can also be done with an internal spiral channel to keep incoming reagents close to the heated wall during entry, as shown above.

It is often desirable to size a tubular reactor to be large enough to fit 8 to 10 catalyst particles across the diameter and be at least 40-50 particle diameters long. The length to diameter ratio can be varied to study the effect of catalyst bed length by equipping the reactor with "spools" placed into the bottom of the reactor to change this ratio.



**Model 5403 with a 1" inside dia. x 24" length, 3-zone split tube furnace with gas feed system, cooling condenser, and gas/liquid separator vessel.**





Open 3-zone Split Tube Furnace with 1" I.D. Tubular Reactor.

Tubular reactor systems are highly customizable and can be made to various lengths and diameters and engineered for various pressures and temperatures, and materials of construction.

A split-tube furnace is provided for heating these vessels. Insulation is provided at each end to minimize heat losses and prevent the end caps from being heated. The heater length is normally divided into one, two, or three separate heating zones, although it can be split into more zones if required.

A fixed internal thermocouple in each zone can be furnished or a single movable thermocouple in a centerline thermowell can be used to measure the temperature at points along the catalyst bed. External thermocouples are typically provided for control of each zone of the heater, as can be seen in the photo above.

### Gas Feed Systems

Various gas feeds can be set up and operated from a **Gas Distribution Rack**. In order to deliver a steady flow of gas to a reactor, it is necessary to provide gas at a constant pressure to an electronic **Mass Flow Controller**. This instrument will compare the actual flow rate delivered to the set point chosen by the user, and automatically adjust an integral control valve to assure a constant flow.

### Series 5400 Tubular Reactor System Specifications

Shaded bar indicates specifications that change within series.

Model Number	5401	5402	5403	5404
<b>Sizes</b>	3/8 in.	1/2 in.	1.0 in.	1.5 in.
<b>O.D. / I.D. (in.)</b>	0.38 / 0.28	0.50 / 0.37	1.50 / 0.99	1.88 / 1.44
<b>O.D. / I.D. (mm)</b>	9.5 / 7.0	13 / 9.5	38 / 25	48 / 36
<b>Heated Length (in.)</b>	6, 12, 24		12, 24, 36	
<b>Maximum Pressure (psi)</b>	3000		5000	3000
<b>Maximum Temperature</b>	550		550	350
<b>Support Spools</b>	No		Optional	
<b>Spiral Pre-Heat</b>	No		Optional	
<b>No. Ports in Top Head</b>	1		4	
<b>No. Ports in Bottom Head</b>	1		4	
<b>Internal Thermocouple</b>	Optional (Moveable or multi-point fixed)			

Care must be taken to size these controllers for the specific gas, flow rate range, and maximum pressure of operation. A mass flow controller needs a power supply and read-out device, as well as a means of introducing the desired set point.

When ordering mass flow controllers, you will need to specify:

1. Type of gas to be metered (e.g. N<sub>2</sub>, H<sub>2</sub>, CH<sub>4</sub>)
2. Maximum operating pressure of the gas (100 or 300 bar)
3. Maximum flow rate range in standard cc's per minute (sccm)
4. Pressure for calibration of the instrument

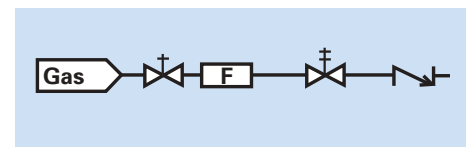
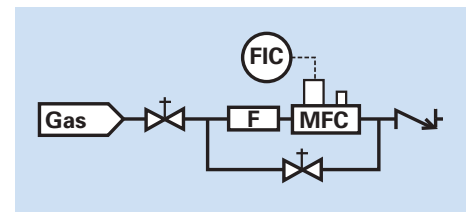

Mass flow controllers are available for use to 1500 psi and to 4500 psi. Considerable savings can be obtained if the mass flow controller is to be used only to 1500 psi.

The schematic at right depicts the installation of a mass flow controller for the introduction of gas to a continuous-flow reaction system. Such installations are enhanced with the addition of a by-pass valve for rapid filling or flushing.

A purge line can also be added. It is typically used for feeding nitrogen or helium to remove air before reaction or to remove reactive gases before opening the reactor at the end of a run. The purge line includes a shut-off valve, filter, metering valve, and a reverse-flow check valve.

Shut-off valves can be automated when using a 4871 Control system.

## Series 5400 Continuous Flow Tubular Reactor Systems



**This 1 liter Tubular Reactor System has two gas feeds, one purge line, and one liquid feed. Custom pressure controls enhance the heated gas/liquid separator.**

### Liquid Metering Pumps

High pressure piston pumps are most often used to inject liquids into a pressurized reactor operating in a continuous-flow mode. For low flow rates, HPLC pumps, many of which are rated for 5000 psig, are excellent choices. Typical flow rates for pumps of this type range up to 10 or 40 mL per minute. Pumps are available to accommodate manual control from their digital faceplate or computer-control from a 4871 Process Controller.

Chemical feed pumps are our recommendation for continuous feeding of liquids when the desired flow rate is greater than 2 liters per hour. Parr can assist with the feed pump selection. We will need to know the type of liquid; the minimum, typical, and maximum desired feed rate; the maximum operating pressure; and any special operating considerations such as corrosion possibilities.

### Cooling Condensers

Cooling condensers are available to cool the products of the reaction. An adaptation of our standard condensers provides an excellent design.

### Back Pressure Regulators

The reactor pressure is maintained by a Back Pressure Regulator (BPR) installed downstream of the reactor. This style of regulator will release products only when the reactor pressure exceeds a value preset by the operator.

When a BPR is used in conjunction with mass flow controllers, the user can maintain a constant flow of gas through a reactor held at an elevated constant pressure. This provides for the highest degree of control and reproducibility in a continuous-flow reactor system.

An alternate BPR may be available to permit pressure let-down of a two-phase stream from the reactor. This BPR requires that the operator provide a source of nitrogen or air at a pressure slightly above the desired operating pressure. With this style of BPR, the high-pressure gas/liquid separator can be replaced with a low-pressure liquid product receiver allowing collection of near real-time liquid samples.



**This continuous flow stirred reactor system is on a cart with our Modular Frame System. This modular frame allows for easy access and flexibility in hook-ups, accessories, and flow, including an interchangeable tubular reactor.**

### Gas/Liquid Separators

Tubular reactors operating in continuous-flow mode with both gas and liquid products will typically require a Gas/Liquid Separator. The separator is placed downstream of the reactor, often separated from the reactor by a cooling condenser. In the separator vessel, liquids are condensed and collected in the bottom of the vessel. Gases and non-condensed vapors are allowed to leave the top of the vessel and pass to the back pressure regulator. It is important to operate the standard BPR with a single fluid phase to prevent oscillation of the reactor pressure.

The gas/liquid separator can be sized large enough to act as a liquid product receiver that is drained periodically. Many of the non-stirred pressure vessels made by Parr are ideally suited for use as gas/liquid separators. Vessels of 300, 600, 1000, or 2000 mL are commonly chosen. Upon request, the bottom of the separator can be tapered to facilitate draining.

### Control and Data Acquisition Systems

A variety of solutions exist to meet the needs of system operators. System accessories such as heaters, mass flow controllers, and pumps can be obtained with individual control packages to create a Local Control System (LCS) based on our 4838 and 4848 Controllers.

As the number of channels to be controlled increases, economics and convenience will often dictate that the system of individual controllers should be replaced with the computer-based Model 4871 Process Controller (PCC).



**This tubular reactor system features a single-zone 12-inch long heater to take reactor temperatures to 500 °C. The gas feed system includes automated shut-off valves on the three MFCs and on the purge line. The Gas/Liquid Separator vessel is jacketed to allow for subambient cooling. Operator controls the system via a remote PC using the included Model 4871 Process Controller.**

# Series 5400 Continuous Flow Tubular Reactor Systems

On this page are schematic representations of typical tubular reactor systems, along with a symbols chart to facilitate understanding. We have provided an ordering number for each of these examples.

## Key to Symbols

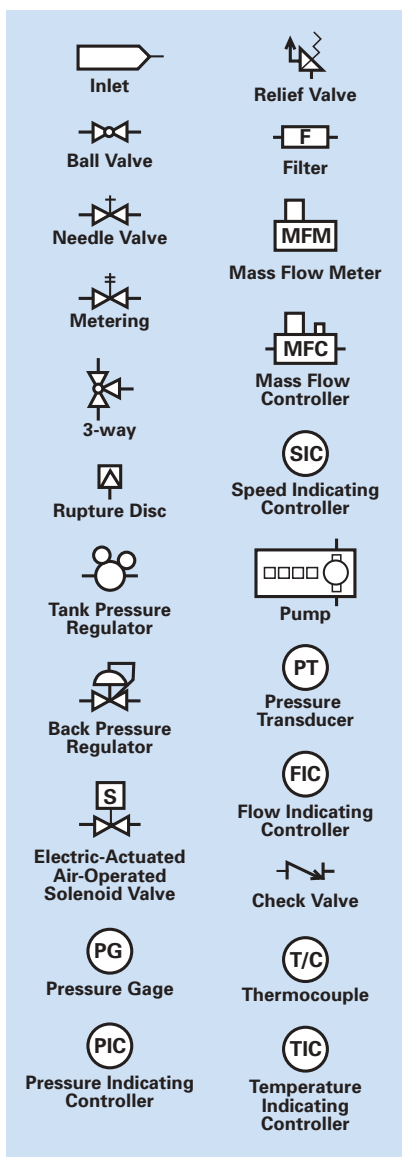

Order No. for this system would be:

**5402B-SS-115-ST1(6)-1500-LCS-GF(1)-PL-LF(1)-ITW-CCD-GLS(300)-MPC**

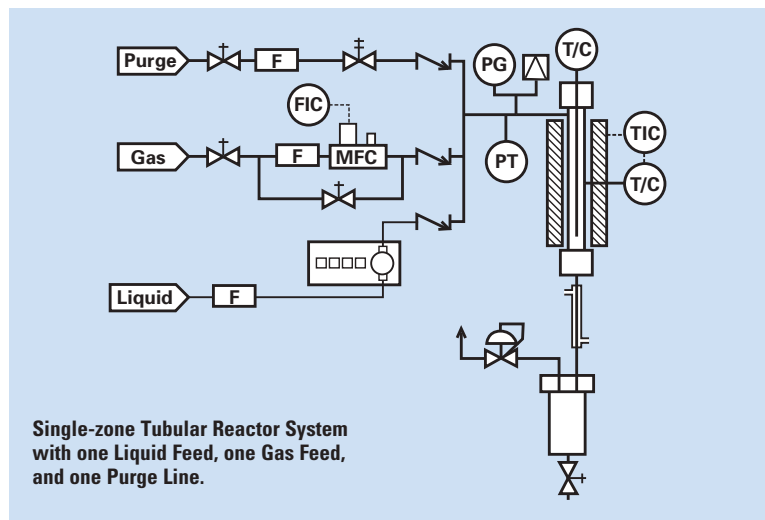

Order No. for this system would be:

**5403F-SS-230-ST3(24)-3000-PCC-GF(2)-PL-LF(1)-ISP-CSS-ITW-GLS(600)-APC-ASV(3)**

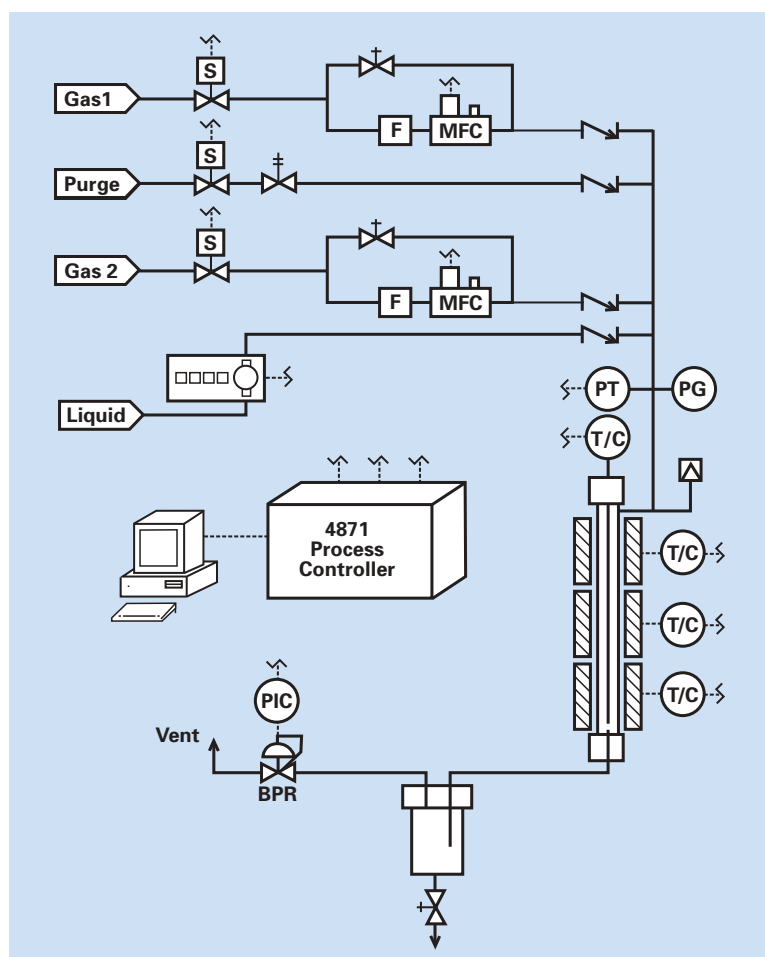

# Series 5400 Ordering Guide

A composite identification number to be used when ordering a 5400 Series Reactor can be developed by combining individual symbols from the separate sections below.

A Base Model	
Model No.	Size (O.D. / I.D.)
5401	3/8 in. (0.38" / 0.28")
5402	1/2 in. (0.50" / 0.37")
5403	1.0 in. (1.9" / 1.0")
5404	1.5 in. (2.0" / 1.5")

Add suffix F for Floor Stand mounting  
Add suffix B for Bench Top mounting

B Materials of Construction	
-SS	T316 Stainless Steel
-HC	Alloy 276
-TI	Titanium
-IN	Alloy 600
-MO	Alloy 400

C Electrical Supply	
-115	115 VAC, 50/60Hz
-230	230 VAC, 50/60Hz

D Heater Options	
-ST1(#)	Split Tube, 1-zone
-ST3(#)	Split Tube, 3-zone
-WJ(#)	Welded Jacket

Add suffix (6), (12), (24), (36) for heated length (in.)

E Maximum Operating Pressure	
-1500	1500 psi / 100 bar
-3000	3000 psi / 200 bar
-4500	4500 psi / 300 bar

F Controller	
-PCC	PC-based Process Control (4871-style)
-LCS	Local Control System (4838-style)

G Custom Options	
-GF(#)	Number of Gas Feeds
-PL	Purge Gas Feed Line
-LF(#)	Number of Liquid Feeds
-ISP	Internal Pre-heat Spiral (5403/5404 only)
-CSS	Catalyst Support Spools (5403/5404 only)
-ITW	Internal Thermowell, with Movable T/C
-IZT	Internal, 3-PT, Fixed T/C
-CCD	Cooling Condenser
-GLS(#)	Gas/Liquid Separator (300, 600, 1000, 2000 mL)
-SPH	Separator Heater
-MPC	Manual Pressure Control
-APC*	Automated Pressure Control
-ASV(#)*	Automated Shut-off Valves (1-12)

\*Available only with 4871 Process Control (PCC)

H Certifications	
-No Symbol	No Certification Required
-PARR	Parr Certification
-ASME	ASME Certification
-PED	PED Certification



The system above has three 250 mL tubular reactors operating in parallel and controlled by a 4871 Process Controller with operator interface on a single PC. This system has weighed and/or heated feed tanks and a two-stage pressure let down.

## Fluidized Bed Reactors



### **Fluidized Bed Reactors are used extensively in the chemical process industries.**

The distinguishing feature of a fluidized bed reactor is that the bed of solid particles or catalyst is supported by an up flow of gas. This reactor provides easy loading and removal of catalyst. This is advantageous when the solids bed must be removed and replaced frequently. A high conversion with a large throughput is possible with this style of reactor. Such reactors inherently possess excellent heat transfer and mixing characteristics.

Fluidized beds have been significantly utilized in chemical processes such as diffusion or heat transfer are the major design parameters. Compared to packed bed, a fluidized bed has notable advantages such as better control of temperature, no hot spot in the bed, uniform catalyst distribution and longer life of the catalyst.

Nearly all significant commercial applications of fluidized bed technology concern gas-solid systems. Applications of fluidized bed reactors include but are not limited to gas-solid reactions, Fisher-Tropsch synthesis, and catalytic cracking of hydrocarbons, and related high molecular weight petroleum fractions. Gasification in a fluidized bed can be utilized to convert coal, biomass and other waste materials into synthesis gas.

**Flexible Mantle Heaters are wrapped around this 36-inch-long, 1-inch I.D. Fluidized Bed Reactor (A) and the Cyclonic Separator (B) to maintain temperatures to 350 °C. This system is also equipped with three gas feeds with automated shut-off valves (C), a cooling condenser (D), a product receiver (E), a back-pressure regulator (F), and a Model 4871 Process Controller (not shown).**

The reactor system pictured at left ([page 84](#)) includes the following key components:

- A gas handling and mixing sub-system used to blend and regulate the flow of reactant gas to the bottom of the reactor.
- A reactor roughly one meter long with a 2.5 cm ID. The lower portion of the reactor incorporates an easily replaced porous metal gas diffusion plate and the top of the reactor widens abruptly to form a disengaging zone for the fluidized bed. Separate heaters are provided for both the main reactor and disengaging zone.
- A moveable thermocouple in a thermowell is provided for monitoring the internal reactor temperature distribution.
- A heated cyclone separator or filter is provided immediately downstream of the reactor to capture the fines resulting from particle attrition.
- The reaction products are then cooled by a condenser and collected in a 600 mL product receiver.
- The system pressure is maintained by an automated, dome-loaded, back pressure regulator.
- All system functions and parameters are monitored and maintained by a Parr 4871 Process Controller (not shown, see [Chapter 6, page 109](#)).

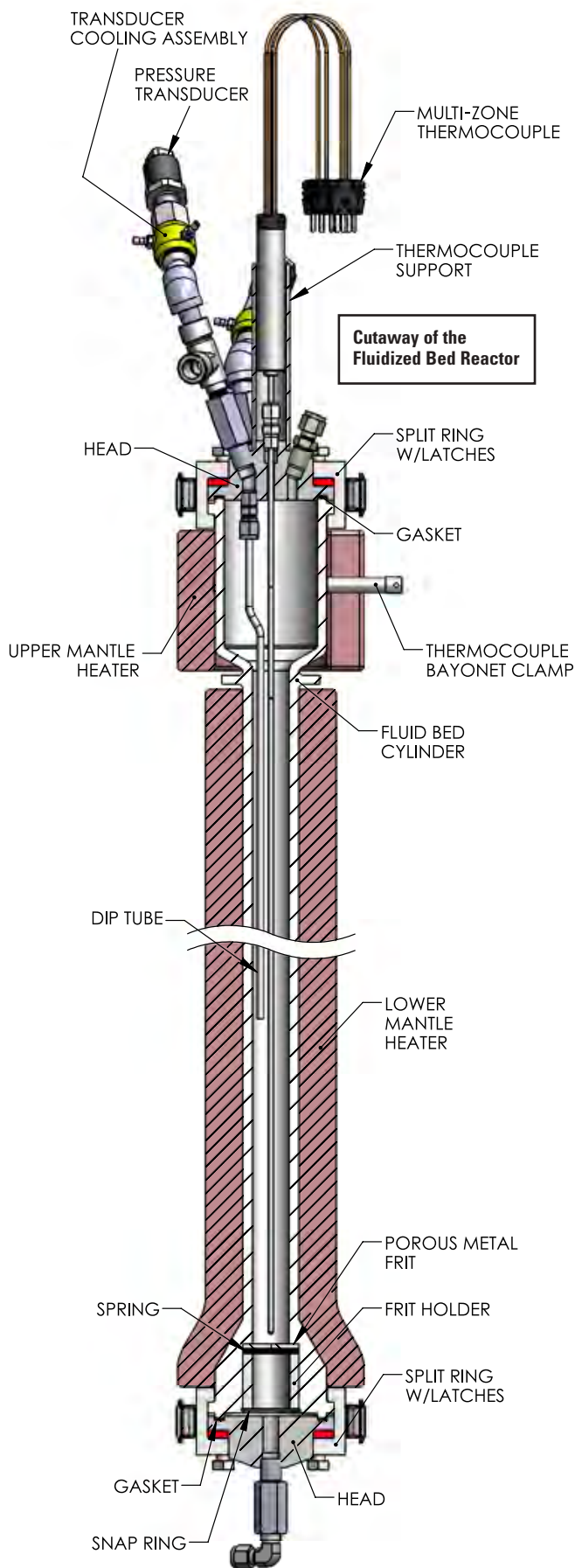

# Fluidized Bed Reactors

# Ordering Guide

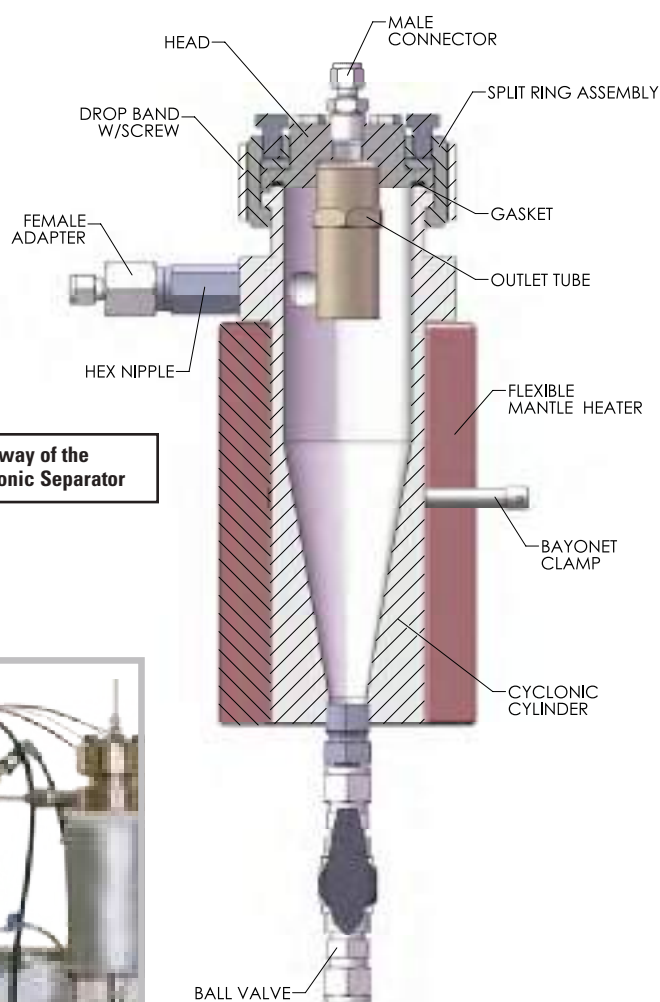

**Cutaway of the  
Cyclonic Separator**



**The Flexible Mantle Heater attaches in two pieces and provides even heating to the entire length of the reactor.**

## A Base Model

### Model No.

5410

## B Materials of Construction

-SS	T316 Stainless Steel
-HC	Alloy 276
-HT	High Temperature Alloy to be determined (for use up to 900 °C)

See *Materials of Construction* on [page 10](#) for other available alloys

## C Electrical Supply

-115	115 VAC
-230	230 VAC

## D Maximum Temperature

-350	350 °C
-600	600 °C
-900	900 °C

## E Cylinder Length

-(36)	36-inches
-(xx)	Other

## F Maximum System Pressure

-500	500 psi / 35 bar
-1500	1500 psi / 100 bar
-3000	3000 psi / 200 bar

## G Control

-PCC	PC-based Process Control (4871-style)
-LCS	Local Control System (4838-style)

## H Custom Options (List all desired)

-GF(#)	Number of Gas Feeds (1-3 or TBD)
-PL	Purge Gas Feed Line
-LF(#)	Number of Liquid Feeds (1-3 or TBD)
-ITW	Internal Thermowell, with Movable T/C
-IZT	Internal, 3-PT, Fixed T/C
-CCD	Cooling Condenser
-GLS(#)	Gas/Liquid Separator (300, 600, 1000, 2000 mL)
-SPH	Separator Heater
-MPC	Manual Pressure Control
-APC*	Automated Pressure Control
-ASV(#)*	Automated Shut-off Valves (1-12)

\*Available only with 4871 Process Control (PCC)

## I Certifications

-No Symbol	No Certification Required
-ASME	ASME Certification
-PED	PED Certification
-P	Parr Certification

Please note that all options and combinations are not compatible with all models.



# Specialty & Custom Reactor Systems **Chapter 5**



Inside this chapter you will find:

[Biofuels and Alternative Fuels Research Systems](#)

[Horizontal Reactors](#)

[Rotating Cage Apparatus](#)

[A1000G Tri-Axial Core Holder](#)

[Supercritical Fluids](#)

[GTL \(Gas-To-Liquid\) System](#)

[Apparatus for Vapor Pressure Determination](#)

[Disbonding Apparatus for ASTM G146](#)

[Apparatus for Corrosion Studies](#)

# Introduction to Specialty Custom Reactors

**P**arr Instrument Company designs and builds a wide variety of specialty and custom reactor systems. These reactor systems embody the spirit of innovation that has made Parr the world leader in laboratory pressure apparatus. Our technical sales, engineering and production teams are happy to work directly with our customers' scientists and/or engineers to very quickly, accurately, and economically proceed from concept to manufacturing. The following pages illustrate several examples of specialty and custom reactor systems designed and built using exactly this collaborative process.

To facilitate collaboration between Parr and our customers as well as to support the high quality of our equipment, we have invested heavily in both design and manufacturing technology. All custom reactor systems are designed with 3D modeling software to create a virtual prototype prior to manufacturing. This model supports clear communication between the customer and Parr and shortens the design phase of such projects. On the manufacturing floor, state of the art, five axis, computer controlled machines programmed and operated by Parr's highly skilled machinists allow rapid and accurate production of even the most complex parts.



**Parr uses the latest technology in milling and manufacturing techniques to produce your custom system to the highest level of precision possible in the field today.**

To match the variety of reactor systems available, our control design and programming team offers multiple types of control systems, ranging from simple, manual temperature control to completely automated and integrated PC-based control, developed to each customer's specification. Control systems are discussed more completely in [Chapter 6](#).

If you have an idea for a reactor system that is not described in this catalog, please contact Parr's world-class technical sales department — there is a very good chance we can build a reactor system to meet your needs.



**Custom-designed Stirred Reactor System for a proprietary process.**



**Pressure vessel with multiple 1-inch diameter windows installed.**

## Biofuels and Alternative Fuels Research Systems



**Custom Reactor Systems like the above Biofuels Research System are a product of collaboration between the researchers and the Engineers at Parr Instrument Company.**

**P**arr Instrument Company manufactures non-stirred vessels for the decomposition of biomass in ammonia and steam. Parr stirred reactors, including a new horizontal reactor technology, have been designed for research processes that include hydrogenation, isomerization, and metathesis reactions. In addition, fully customizable continuous-flow tubular reactor systems have been developed with continuous reactant feed and product handling capabilities. The above photo illustrates a complete pilot scale plant used for hydrogenating feedstock that originates from a proprietary fermentation process. The system is used to develop and optimize the process conditions necessary for a much larger

demonstration-scale system, ultimately leading to full-scale production of renewable fuels.

The system is comprised of five major subsystems: from left to right, a gas and liquid feed system, the jacketed tubular reactor module including a reactant pre-heater and circulating bath, product recovery and backpressure control, an auto-sampler and a Parr 4871 Control System (not pictured). The system is completely automated and includes an auto-sampling subsystem that periodically samples the reactor output stream in order to accurately monitor product quality.

# Horizontal Stirred Reactors

Stirring biomass is not easy to do in a vertical reactor. A line of reactors has been developed by Parr Instrument Company to function horizontally.

Horizontal reactors enable researchers to mix bio feed stock and other cellulosic materials such as:

- straw
- plants
- corn stover
- wood pulp
- sugar cane
- wood chips
- grasses
- fibers

In the horizontal position, the internal stirrers tumble the material rather than try to stir it with a standard vertical stirrer. These custom reactors are secured vertically for loading and then safely tilted horizontally for stirring. They can also be designed to be operated in both a horizontal and vertical position.

**One Liter Horizontal Stirred Reactor with heavy-duty stirring motor in its upright position. A 4848 Controller is used to monitor the system pressure and control the temperature and stirring speed.**

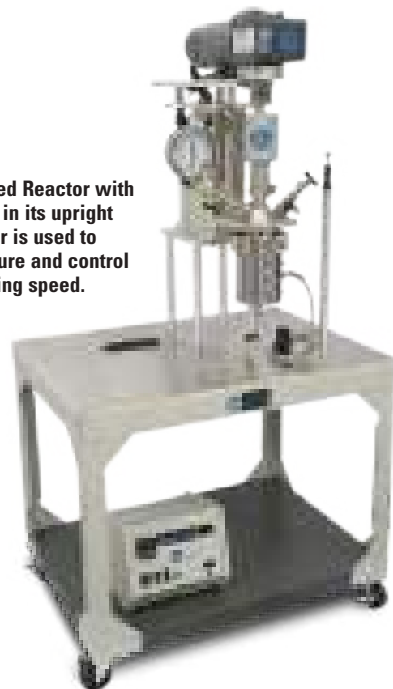

**The 4578 Pressure Reaction System shown above and left is a 1.8 L, fixed head reactor mounted on a floor stand and rated for temperatures up to 500 °C with a maximum pressure of 5000 psig. This system is designed to operate in either a vertical or horizontal position.**

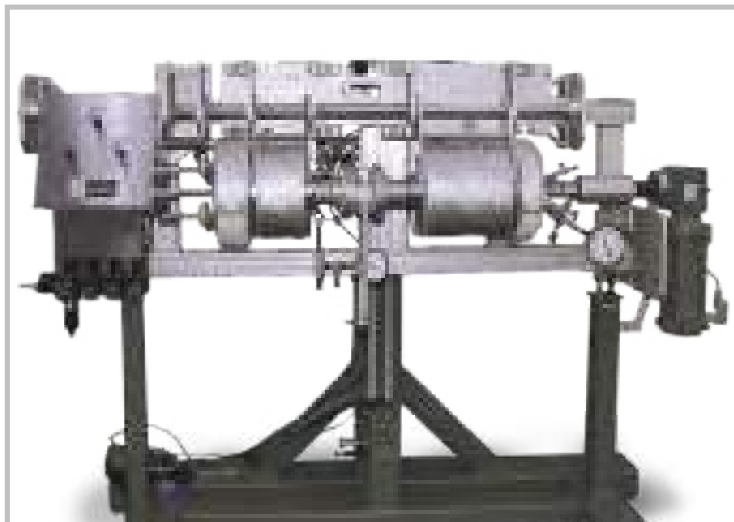

The reactor shown in the two images above and right has a five gallon capacity, and is used for stirring vertically or horizontally. Pneumatic controls on the left can tilt the system upright to open the bottom drain valve. The product is filtered and collected in the lower heated sample collection vessel. This system is used for producing synthetic fabric from biomass as an alternative to a petroleum-based process.

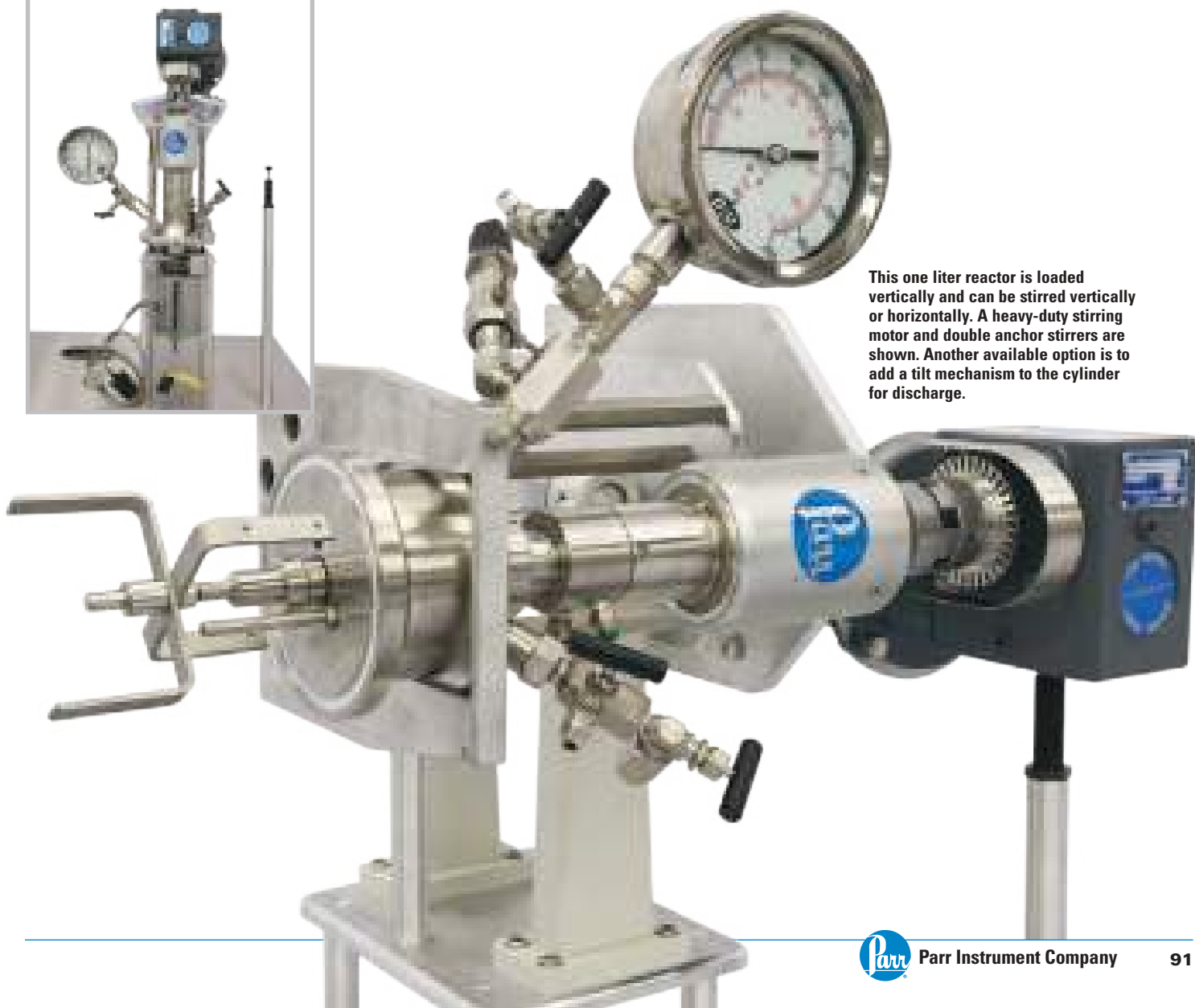

This one liter reactor is loaded vertically and can be stirred vertically or horizontally. A heavy-duty stirring motor and double anchor stirrers are shown. Another available option is to add a tilt mechanism to the cylinder for discharge.

# Rotating Cage Apparatus

For Evaluation of Corrosion Inhibitors per ASTM G170 and Other Methods

Evaluation of corrosion inhibitors for use in refinery and oilfield applications typically requires apparatus that can simulate the interaction between the corrosive fluid and the carbon/low alloy steel used in the construction of the refinery, pipeline, or drilling equipment. ASTM G170 describes the use of a rotating cage (RC) for such testing.

Parr can provide a complete high pressure, high temperature RC system (pictured) which typically includes the following components:

- Reactor system made of Alloy C276 or other corrosion resistant alloy, with included rotating cage
- Gas feed system to deliver CO<sub>2</sub>, H<sub>2</sub>S, or N<sub>2</sub>
- Liquid feed system to deliver acid or inhibitor
- Reflux condenser and pressure controller
- Automated or manual control and data logging system

Pressure and temperature ratings, reactor volume, material of construction, number of gas and liquid feeds, and control system specifics can be customized to meet individual testing requirements.

Contact Parr's Technical Sales team to discuss details.



5 Liter Vessel lowered to reveal the rotating cage. In this configuration, up to 8 coupons at up to 2,000 rpm, can be tested at one time.



## Rotating Cage Apparatus Specifications

Maximum Operating Pressure	200 bar
Maximum Operating Temperature	200 °C
Wetted Materials	C276
Coupon # / geometry	8 / Variable
Reactor Volume	5 L
Max rotation rate	2000 rpm

# A1000G Tri-Axial Core Holder



The A1000G Tri-Axial Core Holder

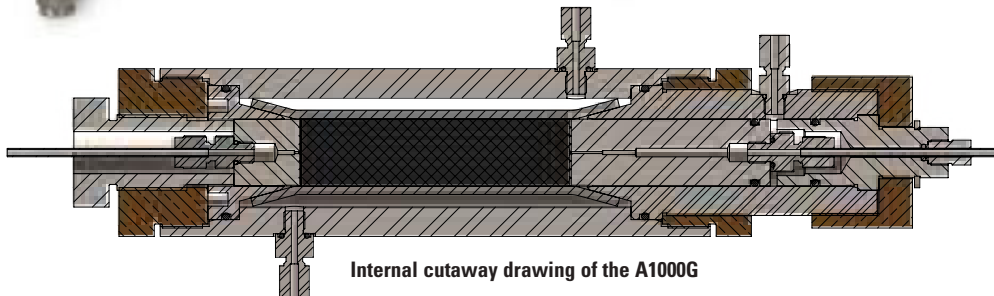

Internal cutaway drawing of the A1000G

In the oil and gas industry it is common practice to take one or more cylindrical core samples of hydrocarbon containing or other formation and to subsequently perform one or more tests with this core sample in a laboratory. During these tests the core sample is contained within a polymeric sleeve inside a pressurized sample holder assembly known as a core holder.

The operating temperature and pressure conditions are substantially similar to the hydrocarbon containing or other formation from which the sample has been taken. A treating, completion and/or stimulation fluid is injected into the sample to determine an optimum composition of the treating, completion and/or stimulation fluid and/or an optimum injection regime.

**Core holders are used to facilitate a variety of studies,** including gas and liquid permeability, formation damage, porosity, carbon dioxide capture and storage (CCS), relative permeability, secondary water flooding, enhanced oil recovery and steam flooding.

A tri-axial type core holder is one where the axial force on the core sample and radial pressure on the sleeve are independent of each other and can be varied during the test. This arrangement is useful in studying the physical characteristics of the core under various conditions. Radial confining pressure is applied through the body wall, along the outer diameter of the sleeved core sample. The axial ram floats

against the rock as axial pressure is applied through the end piece and the rock compresses. A specially designed spider web type groove pattern on the end faces of the core holder's distribution plugs which come in contact with end faces of the core sample. This is to ensure that the fluids, before entering or on exiting the core-sample, are evenly distributed on the whole face of the core-sample.

With this design, the core holder does not need to be completely disassembled in order to interchange core test samples. After the confining pressure has been released the retainer and distribution plugs are removed and the core sample is easily removed from the sleeve. The sleeve and end caps remain in place in the core holder. Spacers

are provided to accommodate shorter cores. The distribution plugs on either end of the core holder are provided with a single inlet / outlet.

**Parr can provide a complete hydrothermal core flooding system which typically includes the following components:**

- The core holder
- One or more high pressure, low flow rate pumps
- A means to maintain the sample at elevated temperature and pressure
- Subsystems to maintain radial and axial pressure on the core sample within the core holder
- Means to monitor and record the differential pressure across the core sample
- A control system to coordinate these functional elements

### A1000G Tri-Axial Core Holder Specifications

Maximum Operating Overburden Pressure	7500 psig
Maximum Operating Temperature	200 °C
Core Diameter	1-in. Nominal
Core Lengths	Up to 4-in.
Wetted Materials	316 SS or other corrosion resistant materials

Variations of this product are not limited to these typical specifications. If a special material or design characteristic is needed, please contact a technical representative at Parr for further information.

# Supercritical Fluids



The batch supercritical water extraction vessel pictured above is constructed of Hastelloy C-276 and is designed for use to 6000 psi (410 bar) at 400 °C.

**A** supercritical fluid is any substance at a temperature and pressure above its critical point. Such fluids can diffuse through solids like a gas and dissolve materials like a liquid. Near the critical point, small changes in pressure or temperature result in large changes in density, allowing many properties of a supercritical fluid to be “fine-tuned”. Supercritical fluids are often suitable substitutes for organic solvents in a range of industrial and laboratory processes.

Carbon dioxide is one of the many commonly used supercritical fluids. It is relatively simple to exceed its critical point (31 °C, 1057 psi). Applications that involve supercritical fluids include extractions, nano-particle and nano-structured film formation, supercritical drying, carbon capture and storage, as well as enhanced oil recovery studies. Parr has provided systems for all the aforementioned applications.

Water is another substance that is often used in its supercritical condition (374 °C, 3185 psi). Its excellent thermal conductivity properties make it the fluid of choice in pressurized nuclear reactors for electricity generation. The extremely aggressive and reactive nature of supercritical water makes it an excellent choice for the oxidative destruction of some hazardous waste materials. This corrosive nature prohibits the use of T316 stainless steel for the vessel and requires the use of a special alloy.

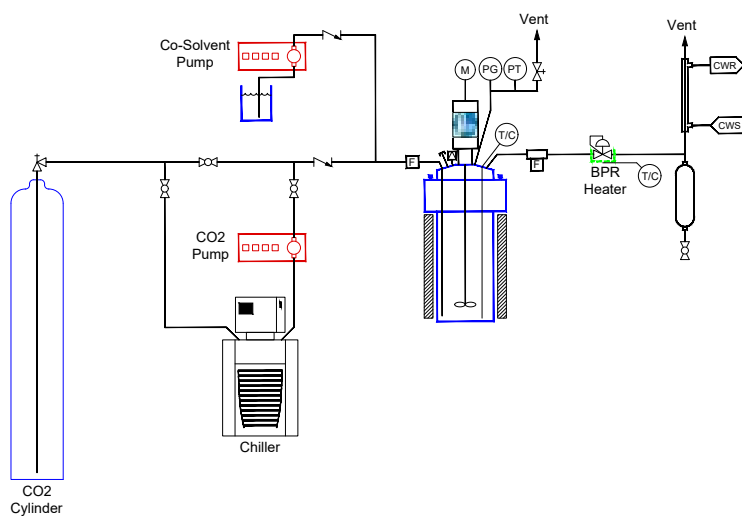

Above is a schematic representation of the batch carbon dioxide extraction system shown at the right.



This batch carbon dioxide extraction system modelled above includes a 1.2 L extraction vessel rated to 5000 psi (345 bar), both CO<sub>2</sub> and co-solvent pumps, automatic pressure control and collection vessel with manual ball valve for extract collection, as well as custom control and data logging system with pre-programmed recipe list.



## GTL (Gas-To-Liquid) System



Parr GTL System

This system incorporates three tubular reactors that can be configured as required to operate in a strictly parallel fashion or in a cascade arrangement where the products from one reactor are immediately directed to a second reactor. This type of system can support reaction schemes including but not limited to the Fisher-Tropsch process, methanation reactions, steam reforming and other similar processes.

The Fisher-Tropsch process converts carbon monoxide and hydrogen into oils or fuels that can substitute for petroleum products. The reaction uses a catalyst based on iron or cobalt and is fueled by the partial oxidation of coal or wood-based materials such as ethanol, methanol, or syngas. This reaction scheme offers a promising route to producing economical renewable transportation fuels. By carefully controlling the temperature and oxygen content, resulting products can range from syngas to “green diesel”.

One of the unique features of this system is a gas blending subsystem capable of mixing up to four reactant gases followed by a controlled delivery of this blended mixture to each of the three reactors via dedicated mass flow controllers.

Downstream components for each reactor include a heat exchanger/condenser, a gas/liquid separator (product receiver) and a fully automated back pressure regulator. The system includes support for introducing liquid reactants via a high pressure metering pump. The system comes completely automated with the addition of the highly versatile 4871 Process Controller (not pictured).

# Other Specialty and Custom Reactor Systems



Pictured above is a custom dual vessel system for the accurate determination of the saturation pressure of specialty organic materials as a function of temperature. All the associated head fittings, valves and plumbing, including the pressure transducers, are enclosed in a heated, temperature controlled, aluminum block to minimize temperature gradients and to ensure that the average system temperature closely matches the temperature of the vessels, including their screw cap closures, housed in the lower temperature controlled block. The photo shows the exposed valves and fittings which are covered by an aluminum plate during normal operation of the system.

## Apparatus for Vapor Pressure Determination

Vapor pressure (also known as equilibrium vapor pressure or saturation vapor pressure), is the pressure of a vapor in equilibrium with its non-vapor phases in a closed container. At a given temperature, the pressure at which a pure liquid boils is called its vapor pressure. Vapor pressures are dependent only on temperature. The vapor pressure of a pure liquid does not depend on the amount of the liquid in the container. Vapor pressures have an exponential relationship with temperature and always increase with temperature.

Investigation on vapor-liquid equilibrium of solutions can be derived from absolute vapor pressure measurements. Vapor-liquid equilibrium (VLE) data are essential for development and design of chemical processes. In the static total pressure method, the total composition in the vessel is determined by loading precise volumes of the components. The measurements are isothermal and the equilibrium pressure is measured. The amount of components in the liquid phase and the vapor phase is calculated iteratively. The static total pressure method is a fast and efficient method for determining VLE for binary mixtures with the additional advantage that the apparatus using the static total pressure method can be easily automated.

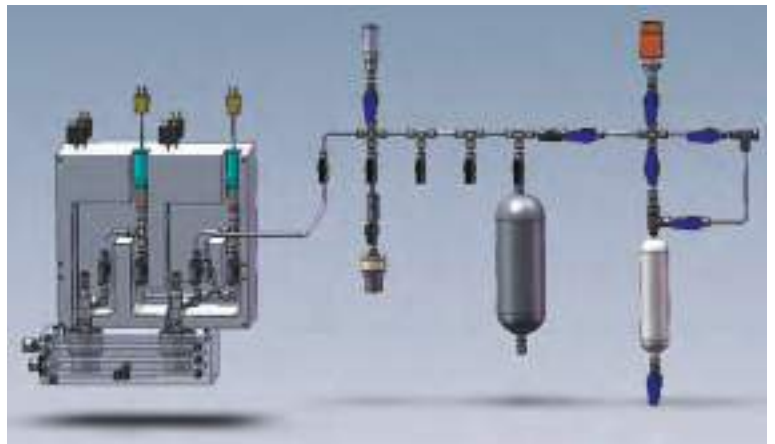

CAD Model for the Vapor Pressure CAD Model for the Vapor Pressure Apparatus

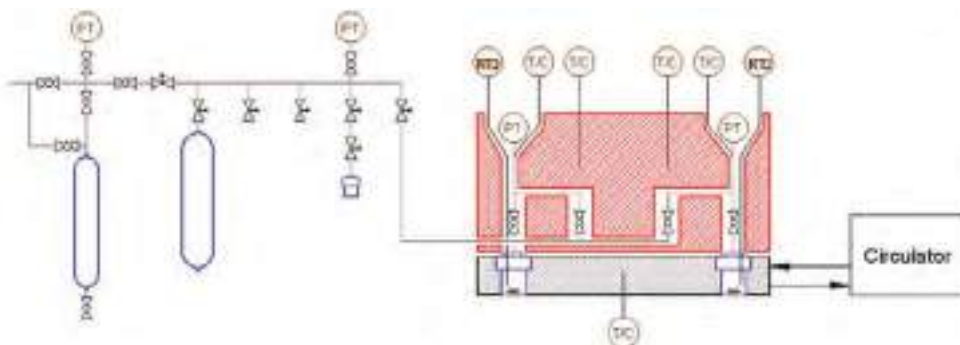



#### Disbonding Apparatus for ASTM G146

Parr Instrument Company has developed an automated reactor system for the evaluation of disbonding of bimetallic stainless alloy/steel plate. This hydrogen disbonding reactor system is capable of attaining the conditions necessary for treating samples consisting of bimetallic plate typically used in the refining industry for High Pressure/High Temperature hydrogen gas service. The test temperature and hydrogen gas pressure are selected to simulate those conditions found in refinery hydrogen-containing environments. These typically range from 14 to 20 MPa hydrogen gas pressure and temperature from 300 to 500 °C depending on actual refinery service conditions under consideration. The purpose of this test scheme is to allow for comparison of data among test laboratories on the resistance of bimetallic stainless alloy/steels to hydrogen induced disbonding (HID). This test procedure provides an indication of the resistance or susceptibility, or both, to HID of a metallurgically bonded stainless alloy surface layer on a steel substrate due to exposure to hydrogen-containing gaseous environments under HP/HT conditions. This system can be used over a broad range of pressures, temperatures, cooling rates, and gaseous hydrogen environments where HID could be a significant problem. These tests can be used to assess the effects of material composition, processing methods, fabrication techniques, and heat treatment as well as the effects of hydrogen partial pressure, service temperature, and cooling rate. This testing regime is fully described in ASTM Standard Practice G 146.

The apparatus developed by Parr consists of an HP/HT test cell made from Inconel 625. Two gas booster pumps, one for nitrogen and the other for hydrogen, are used for pressurizing the test cell. The system incorporates an automated back pressure regulator and a variety of automated valves for pressure control. The control system for the apparatus automatically purges the vessel with argon, performs a high pressure leak test with nitrogen and then sequences the main portion of the test. The main test consists of filling the test cell with hydrogen, heating the vessel at a user defined temperature set point for a period of typically 48 hours. After this, the vessel is cooled at a predefined rate, typically 150 °C/hr, until the inside temperature reached 200 °C. The test cell is then automatically vented, purged and cooled further so that the test samples can be safely retrieved. All important test parameters are user adjustable.



#### Apparatus for Corrosion Studies

This custom vessel was designed specifically to be used for long term (up to 4000 hours) corrosion testing of zirconium alloy samples in aqueous solutions near the critical point of water.

The vessel illustrated is a non-stirred, fixed head design with a volume of 3.7 liters with a maximum working temperature and pressure of 450 °C and 275 bar, respectively.

The vessel is heated with three clamp-on style band heaters. The system is capable of maintaining a uniform temperature of  $\pm 1$  °C over a working zone of 30 cm. Valves are provided on the head of the vessel for purging with inert gas prior the start the test as well as periodic sampling of the contents of the vessel. The controller is equipped to record temperature and pressure data for the duration of the test.

For more information on any of these custom systems please visit [www.parrinst.com](http://www.parrinst.com) or contact the Parr Technical Service Department.

---

# Notes

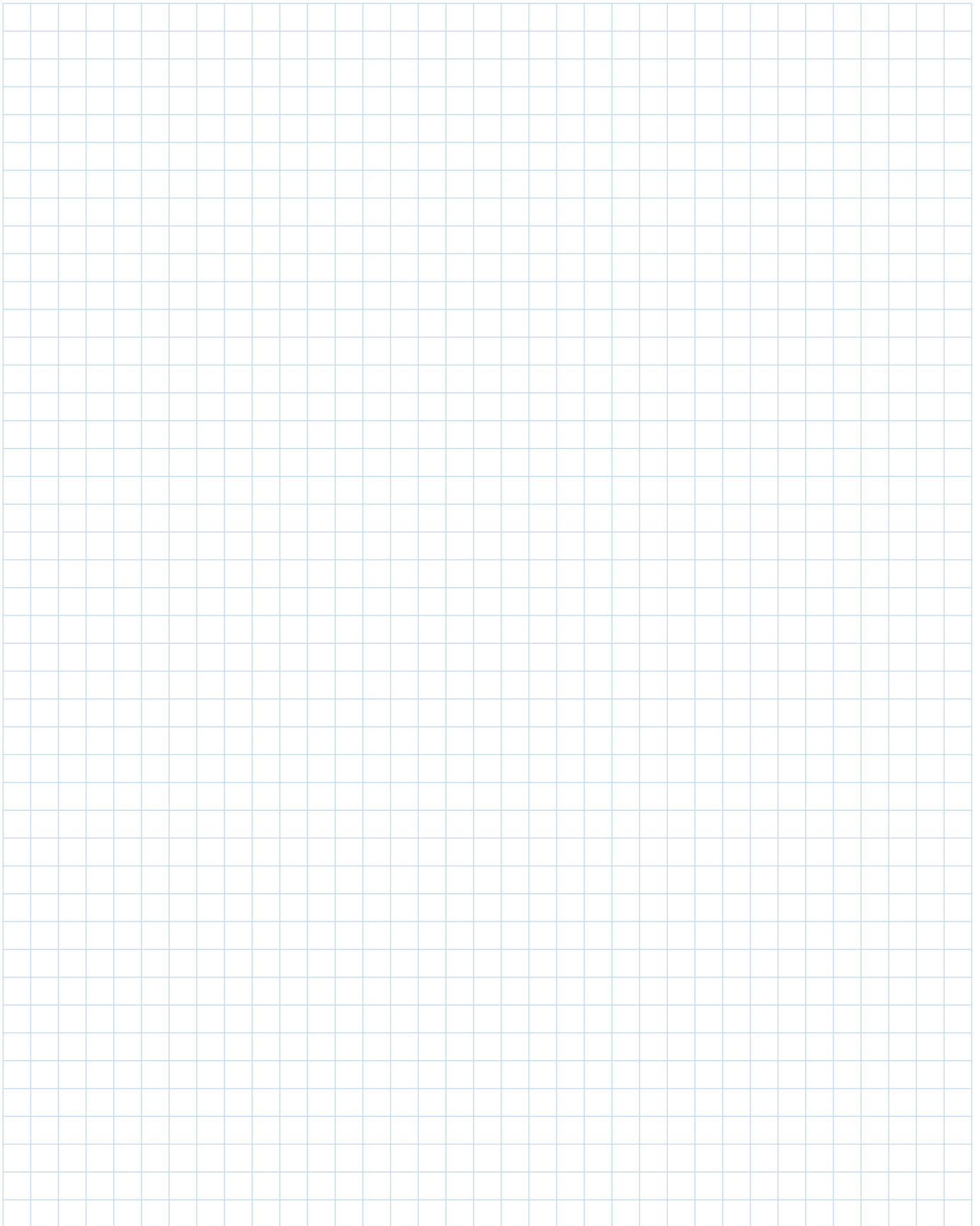

# Reactor Controllers **Chapter 6**



**Inside this chapter you will find:**

## **Controller Overview**

**4848** [Reactor Controller](#)

**4848B** [Expanded Reactor Controller](#)

**4848M** [Master Controller](#)

**4848A** [Reactor Controller for AC Motors](#)

**4848T** [Touchscreen Controller](#)

**4838** [Temperature Controller](#)

**A3504HC** [Specview Software](#)

**4871** [Process Controller](#)

**4875** [Power Controller](#)

**4876** [Power Controller](#)

**4877** [Valve Controller](#)

**A2110E** [Motor Controller](#)

**A2200E** [Flow Controller Interface](#)

# Parr Controller Overview

**The Model 4848 Reactor Controller** is our general-purpose reactor controller. It can control temperature and stirring speed, and it can be equipped to monitor a redundant temperature and pressure. It can datalog and be operated remotely from a PC.



**The Model 4848B Reactor Controller** is an expanded reactor controller. It has the same capabilities as the 4848 but with a larger chassis. The 4848B can accommodate up to six meters, plus the Primary Temperature Module.



**The Model 4838 Reactor Controller** is offered to control temperature in non-stirred pressure vessels. It can be expanded to include an optional pressure or redundant temperature module.



**The Model 4871 Process Controller** is a full featured process controller, which can handle either a single reactor with a wide variety of inputs and outputs or multiple reactors running independently. It controls the entire process including gas and liquid flows through a PC interface custom tailored to the application.



## Parr Instrument Company offers a full line of reactor controllers to monitor, control, datalog, and archive test data.

**The Model 4848T Reactor Controller** is a touchscreen controller for use with a single reactor system. It has the same control capabilities as a fully-loaded 4848 with Motor Control Module, Pressure Display Module, and secondary temperature module, with touchscreen interface and VNC communication capability.

**The Model 4848M** is a controller for Master/Slave setups. It is most often used with large reactors with multi-zone heaters where each zone draws enough power to require its own power supply.

**The Model 4848A** is a reactor controller for use with AC Motors.

**The A2110E is a Motor Controller.** It can be provided with or without a tachometer display.

**The A2200E is a Mass Flow Controller Interface.** It can handle up to four Mass Flow Controllers at one time.

**The 4875 Power Controller** is utilized with a 4871 Process Controller or a 4848M Master Controller.

**The 4876 Power Controller** is utilized with a 4871 Process Controller or 4848M Master Controller. It can handle up to three heater outputs and is only available in 230V.

**The 4877 Valve Controller** is utilized with a 4871 Process Controller to actuate valves.

**The A3504HC SpecView Software** is enhanced software for use with the 4848 or 4838 Controllers. It provides superior datalogging and has an excellent user interface.

	<b>4848</b>	<b>4848B</b>	<b>4848T</b>	<b>4838</b>	<b>4871</b>
<b>Application:</b>	One Stirred Reactor	One Stirred Reactor	One Stirred Reactor	One Non-Stirred Pressure Vessel (No Motor Control or cooling)	Advanced Systems*
<b>Features:</b>					
Temperature Control	One	One	One	One	Multiple
Pressure Monitoring	Optional	Optional	One	Optional	Multiple
Motor Speed Control	One	One	One	None	Multiple
Auxiliary I/O	None	Up to two inputs	None	None	Multiple
Redundant Temperature Monitoring	Optional	Optional	One	Optional	Multiple
PC User Interface with Datalogging	Optional	Optional	VNC	Optional	Included
Digital Communications	RS-485	RS-485	Ethernet	RS-485	Ethernet
Expansion Modules	Up to Three	Up to Six	Three Included	Up to One	Unlimited
Number of Reactors Controlled	One	One	One	One	Multiple

\* Contact a Parr Customer Service Representative for your custom application needs.

# 4848 Reactor Controller



4848 Reactor Controller shown with PTM, MCM, PDM, and HTM Modules installed.

## The 4848 Reactor Controller

brings digital communications to all of the functions of this modular reactor controller. The 4848 offers all of the features expected in a Parr general purpose reactor controller, namely:

- PID programming with Auto-tuning capability for precise temperature control and minimum overshoot
- Ramp and soak programming
- Separate heating and cooling control loops
- Optional Solenoid Valve Module for cooling control
- Motor speed control
- High or low power heater switch
- Lockout relay and reset for over temperature protection
- Optional expansion modules for tachometer, pressure, and high temperature alarm

With the Parr 4848 Reactor Controller, all of the expansion modules as well as the primary temperature control module are equipped with bi-directional digital communications [RS-485] that enable the user to not only log all current readings to a PC, but also to send set points, stirrer speeds, and alarm values from the PC to the 4848 Controller.

### Modular Design

A total of seven different modules are offered for the 4848 Controller. A maximum of three expansion modules in addition to the primary temperature control can be installed in the 4848 Controller. The user can select either the Tachometer Display Module or the Motor Control Module. This either/or option also applies to the High Temperature Cut Off and External Temperature Limit Modules.

The 4848B has a larger chassis to accommodate up to six expansion modules.

### 1. Primary Temperature Control Module (PTM)

The temperature control module can accept either thermocouples or RTD temperature sensors. It has three outputs that are used for heating and cooling control and for alarm-actuated heater cut off. The control function is a full proportional, integral and derivative (PID) control with auto-tune capabilities. The controller provides ramp and soak programming with up to 49 segments.

### 2. Pressure Display Module (PDM)

This pressure monitoring module is set up to accept its input from a pressure transducer mounted on the reactor or attached accessory. It can be set to accept a wide variety of operating ranges. Operating pressures are transmitted continuously to the PC. These modules are available calibrated in either psi, bar, or mPa. The output from the pressure monitoring module is connected to the alarm relay to shut off power to the heater if the high pressure limit set by the operator is reached during operation.

### 3. Tachometer Display Module (TDM)

In this configuration, the module will display the stirrer speed and will continuously transmit it to the PC for display and logging. The stirrer speed is set manually using a potentiometer on the face of the 4848 Controller.



#### 4. Motor Control Module (MCM)

In this configuration, the module provides true closed loop feedback control of the reactor stirring speed. The primary output of this module is wired to dynamically adjust the motor voltage in response to changes in motor loading. This provides better reactor stirring speed regulation than the standard open loop speed control, especially with reactions that involve changing viscosities. Additionally, the use of this module allows the stirring speed set point to be adjusted remotely from the host PC. A by-product of this closed loop speed control scheme is that the value of the primary controller output directly reflects the degree of loading on the motor in order to maintain a constant stirring speed. While not a direct torque measurement, this is a useful option for those who want to monitor the progress of a reaction where there is a change in viscosity as the reaction proceeds.

#### 5. Motor Torque Module (MTM)

The MTM will display motor output from an MCM. It is particularly useful for applications with changing viscosities.

#### 6. High Temperature Cut Off Module (HTM)

The high temperature cut off module or limit controller augments the operation of the main control module. Its redundant sensor can be mounted either internally or externally to the reactor. The primary output of the module is wired to activate the lockout relay in order to provide safety shutdown should the reactor reach an unsafe temperature.



4848 back panel for 115V model.

#### 7. External Temperature Limit Module (ETLM)

This configuration uses the same aforementioned HTM Module with its sensor mounted in such a way to monitor the reactor's outside wall temperature. The primary output of this module is used to limit the external temperature of the reactor. This is done by interrupting the control signal from the main temperature controller when the external temperature exceeds a predetermined value. The secondary output of this module is used to activate the lockout relay in a non-latching manner if the outside wall temperature exceeds a preset unsafe temperature. The use of this module provides an effective alternative to cascade control, offering improved temperature

regulation in systems with large thermal lags, such as those found in non-stirred reactors or systems that use PTFE liners, as well as systems where the reactants have low heat capacities, such as gas phase reactions.

#### 8. Solenoid Valve Module (SVM)

This package includes a solenoid valve and a flow adjustment valve with all of the parts required to assemble an automatic system to control the flow of coolant through a cooling coil in any reactor. It plugs into the cooling output socket on the 4848. It is designed for use with tap water as the cooling media.

*4848 Continued next page >*

# 4848 Reactor Controller



The 4848B Reactor Controller is a larger version of the 4848 with up to six expansion modules

< Continued from previous page

## 4848B Expanded Reactor Controller

The 4848B Expanded Reactor Controller is a larger version of the 4848 Reactor Controller. It has the same Primary Temperature Control Module as the 4848, and can accommodate up to six expansion modules. It will also communicate with the A3504HC SpecView software.

The 4848B is most useful when the process requires more modules than a single 4848 can handle. A common application would be a stirred reactor which requires a pressure display showing internal pressure and the pressure of an external gas burette. The 4848B has a chassis with enough space to handle both burettes and associated cables and other infrastructure.

The 4848B also has two optional Auxiliary modules. These will read an analog signal, most commonly 4-20 mA or 0-5 VDC. These can be fed into the chassis through a dedicated auxiliary input slot.

## 4848M Master Controller

The 4848M Master Controller is typically used with multi-zone heaters such as those used on our 4555 Series Stirred Reactors. It will interface with one or more slave boxes, allowing a dedicated power supply to be used for each zone.

## 4848A Reactor Controller for AC motors

The 4848A can be used with AC Motors. DC motors are more or less ubiquitous in Parr equipment, but some specialty applications require AC motors. The 4848A allows a tachometer display or motor control module to be used with an AC motor.

# 4848 Ordering Guide

A composite identification number to be used when ordering a 4848 Reactor Controller can be developed by combining individual symbols from the separate sections.

Example: A 4848 Reactor Controller, 115V electrical, with Tachometer Display Module, Solenoid Valve Module, RS-485 to USB Cable, and SpecView Package would be listed as:

**No. 4848-EB-TDM-SVM-A1925E4-A3504HC**

A.	B.	C.	C.	C.	C.
Model	Voltage	Options	Options	Options	Options
4848	-EB	-TDM	-SVM	-A1925E4	-A3504HC

## A Base Model

PID, Ramp & soak digital communications with motor speed control and software

Model No.	Description
4848	Reactor Controller for use with up to three additional display modules
4848B	Reactor Controller for use with up to six additional display modules
4848M	Master Controller
4848A	Reactor Controller for AC Motors

## B Electrical Supply

-EB	115 VAC
-EE	230 VAC

## C Options

-TDM	Tachometer Display Module
-MCM	Tachometer w/Motor Control Module
-PDM	Pressure Display Module
-HTM	High Temperature Cut Off Module
-ETLM	External Temperature Limit Module
-MTM*	Motor Torque Module
-SVM	Solenoid Valve Module (for Cooling Control)
-AUX	0-5 VDC, 4-20 MA (4848B Only)
-A1925E4	RS-485 to USB Cable for 4848 Controller (required for data logging)
-A1925E6	RS-485 to USB Converter, isolated, 30-ft
-A2208E**	RS-485 Daisy Chain for Multiple Controllers, 10-ft
-A3504HC	SpecView Software Package

\*The MTM module must be installed in conjunction with the MCM.

\*\*Must be used with A1925E6.

## Dimensions

Model	Width, in.	Height, in.	Depth, in.
4848	11.1	9.7	11.3
4848B	13.6	9.6	11.3
4848M	11.1	9.7	11.3
4848A	13.6	9.6	11.3

Series Number:

**4848T**

# 4848T Touchscreen Reactor Controller

**The Parr Model 4848T Controller** brings a new touchscreen design to our controller line. This full featured controller has the same functionality as a fully populated 4848 Reactor Controller but with a touchscreen interface.

### Connectivity

The Model 4848T is designed for superior connectivity via network communications. After connecting to your network, the Model 4848T can communicate with your tablet, phone, or PC via a built-in web or VNC server.

### Module Features of 4848T

The Model 4848T Controller is offered as a fully populated controller with Primary Temperature Control, Motor Control Module, Pressure Display Module, and secondary temperature module.

### Primary Temperature Control Module (PTM)

The temperature control module can accept either a thermocouple or RTD temperature sensor. It has three outputs that are used for heating and cooling control and for alarm-actuated heater cut off. The control function is a full proportional, integral and derivative (PID) control with auto-tune capabilities. The controller provides ramp and soak programming with up to 64 steps.

### Pressure Display Module (PDM)

This pressure monitoring module is set up to accept its input from a pressure transducer mounted on the reactor or attached accessory. It can be set to accept a wide variety of operating ranges. Operating pressures are displayed



4848T Reactor Controller

continuously. These modules are available calibrated in either psi, bar, or mPa. The output from the pressure monitoring module is connected to the alarm relay to shut off power to the heater if the high pressure limit set by the operator is reached during operation.

### Motor Control Module (MCM)

In this configuration, the module provides true closed loop feedback control of the reactor stirring speed. The primary output of this module is wired to dynamically adjust the motor voltage in response to changes in motor loading. This provides better reactor stirring speed regulation than the standard open loop speed control, especially with reactions that involve changing viscosities. A by-product of this closed loop speed control scheme is that the

value of the primary controller output directly reflects the degree of loading on the motor in order to maintain a constant stirring speed. While not a direct torque measurement, this is a useful option for those who want to monitor the progress of a reaction where there is a change in viscosity as the reaction proceeds.

### High Temperature Cut Off Module (HTM)

The high temperature cut off module or limit controller augments the operation of the main control module. Its redundant sensor can be mounted either internally or externally to the reactor. The primary output of the module is wired to activate the lockout relay in order to provide safety shutdown should the reactor reach an unsafe temperature.

*4848T Continued next page >*

# 4848T Touchscreen Reactor Controller

# Series 4848T Ordering Guide



4848T back panel for 115V model.

< Continued from previous page

## External Temperature Limit Module (ETLM)

This configuration uses the same aforementioned HTM Module with its sensor mounted in such a way to monitor the reactor's outside wall temperature. The primary output of this module is used to limit the external temperature of the reactor. This is done by interrupting the control signal from the main temperature controller when the external temperature exceeds a predetermined value. The secondary output of this module

is used to activate the lockout relay in a non-latching manner if the outside wall temperature exceeds a preset unsafe temperature. The use of this module provides an effective alternative to cascade control, offering improved temperature regulation in systems with large thermal lags, such as those found in non-stirred reactors or systems that use PTFE liners, as well as systems where the reactants have low heat capacities, such as gas phase reactions.

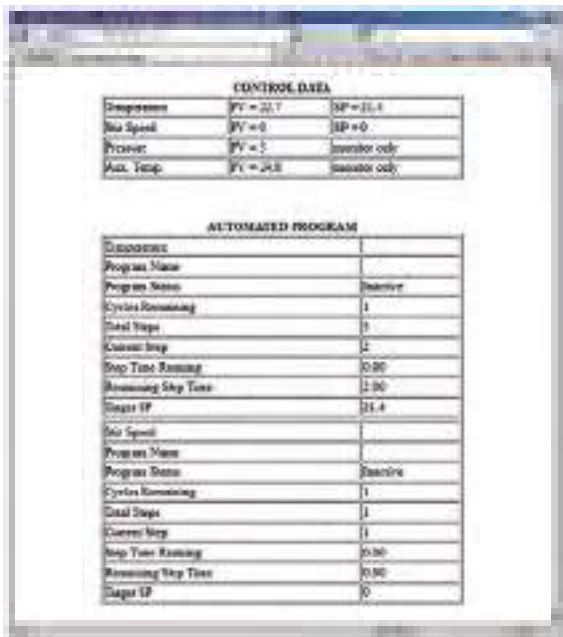

4848T Communications via IP Network

A composite identification number to be used when ordering a 4848T Reactor Controller can be developed by combining individual symbols from the separate sections.

Example: A 4848T Reactor Controller, 115V electrical, with High Temperature Module, for use with 1/4 HP motor would be listed as:

## No. 4848T-EB-HTM-VS.25

A.	B.	C.	D.
Model	Voltage	Options	Motor
4848T	-EB	-HTM	-VS.25

### A Base Model

Touchscreen, PID, Ramp & soak digital communications with motor speed control and software

Model No.	Description
4848T	Touchscreen Controller with Primary Temperature Control, Motor Control Module, Pressure Display Module, and either High Temperature Module or External Temperature Limit Module

### B Electrical Supply

-EB	115 VAC
-EE	230 VAC

### C Secondary Temperature Option

-HTM	High Temperature Module with redundant thermocouple
-ETLM	External Temperature Limit Module with external thermocouple mounted through heater VAC

### Dimensions

Model	Width, in.	Height, in.	Depth, in.
4848T	11.5	12.7	13.3

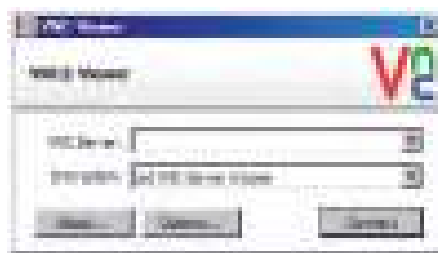

4848T Communications via VNC

Series Number:

4838

# 4838 Reactor Controller

The **4838 Reactor Controller** is designed to control the temperature in our line of non-stirred pressure vessels. No provision is made for the current or future expansion to control motor stirring speeds or to actuate cooling water. The controller contains the same Primary Temperature Control Module used in the 4848 Controller and provides identical control and communications capabilities. A high/low heater switch feature, as well as a lockout relay and reset for over temperature protection, are also included. The 4838 Reactor Controllers can be enhanced with the addition of either a Pressure Display Module (PDM) or High Temperature Cut Off Module (HTM). An External Temperature Limit Module (ETLM) can be substituted for the HTM.

Features found on the 4838 Reactor Controller are:

- PID programming with Auto-tuning capability for precise temperature control and minimum overshoot
- Ramp and soak programming
- High or low power heater switch
- Lockout relay and reset for over temperature protection.



Parr 4838 Reactor Controller shown with optional HTM Module

## Series 4838 Ordering Guide

A composite identification number to be used when ordering a 4838 Reactor Controller can be developed by combining individual symbols from the separate sections.

Example: A 4838 Reactor Controller, 115V electrical, with optional Pressure Display Module and SpecView Software would be listed as:

**No. 4838-EB-PDM-A3504HC-A1925E4**

A. Model	B. Voltage	C. Options	C. Options	C. Options
4838	-EB	-PDM	-A3504HC	-A1925E4

### A Base Model

For Non-Stirred Vessels, PID, Ramp and Soak, Digital Communications and Software

Model No.	Description
4838	Reactor Controller

### B Electrical Supply

-EB	115 VAC
-EE	230 VAC

### C Options

-PDM	Pressure Display Module
-HTM	High Temperature Cut Off Module
-ETLM	External Temperature Limit Module
-A1925E4	RS-485 to USB Converter with 30-ft. Cable
-A1925E6	RS-485 to USB Converter, isolated, with 30-ft. Cable
-A3504HC	SpecView Software Package for 4848 and 4838

### Dimensions

Model	Width, in.	Height, in.	Depth, in.
4838	10.19	7.11	7.92

# SpecView® Software for 4848 and 4838 Controllers



SpecView Graphic User Interface for 4848 and 4838 Controllers

## SpecView Software

The unified Modbus communication architecture of the 4848 allows us to bring the power and convenience of SpecView to the 4848 and 4838 Series Controllers. This version of SpecView provides support for up to eight individual loop or limit controllers.

## SpecView Features and Benefits:

- Real time charting
- Datalogging
- Alarm and event logging
- Superior alarm annunciation
- Customizable graphical user interface

This powerful program is highly customizable and configurable to show variables beyond the process value such as heater output, motor output or alarm status. Notes are easily inserted into the interface and data, and the entire interface can be rearranged and edited for the intended process.

## PC Requirements:

SpecView runs on the following Windows operating systems:

- Windows 10, 8, 8.1, & 7; 32 bit & 64 bit
- Note: SpecView does not work on Windows 8 RT (as found on some Microsoft Surface tablets)

## Parr recommends a minimum of:

- Intel Pentium processor or equivalent AMD
- 2GB RAM
- 1GB hard disk space for SpecView and related utilities
- Additional disk space for datalogging
- Display adapter capable of operating at 1024 x 768 pixels and at least 16-bit color
- 2 USB ports
- A CD-ROM drive

Series Number:

4871

# 4871 Process Controller

The **4871 Process Controller** has been developed to provide an integrated stand alone control system for controlling either a single reactor with multiple feed and product controls or multiple reactors operating independently or in parallel. The 4871 is the ideal choice for all of Parr Instrument Company's custom systems, including: tubular reactors, multiple reactor systems (both batch and cascade systems), continuous flow stirred reactors, and fluidized bed reactors.

### Control Module

The control module of the Parr 4871 Process Controller is a Honeywell HC900 Hybrid Controller. This controller combines analog and logic control into a versatile, cost-effective controller designed specifically for process applications requiring analog measurement combined with programmable control actions.

Function	
Analog Input (AI) Maximum Channels	480
Analog Output (AO) Maximum Channels	200
Digital I/O Maximum Channels	1920
Remote I/O	Yes
Control Loops	Per Memory
Logic Scan	25-50 ms
Loop Scan	500 ms
Ethernet Communications	Yes
Peer to Peer Communications	Yes
Modbus Master	Yes
Modbus Slave	Yes
On-line Programming	Yes
Function Blocks	2000
Sequential Functions	Yes
E-mail Alarms	Yes

### Input / Output

The controller is adapted to each user's requirements by adding to the control chassis input and output modules. Each module provides for between four and sixteen individual inputs or outputs fully isolated from one another.

These modules include:

### Input Modules

The analog inputs are of universal type and are most commonly used for thermocouple or RTD temperature sensors, strain gage type pressure transducers, and similar devices with mV, V, or resistance inputs. Input isolation, cold junction compensation, and burnout protection are incorporated into the circuitry. Each analog input module provides for eight separate inputs.

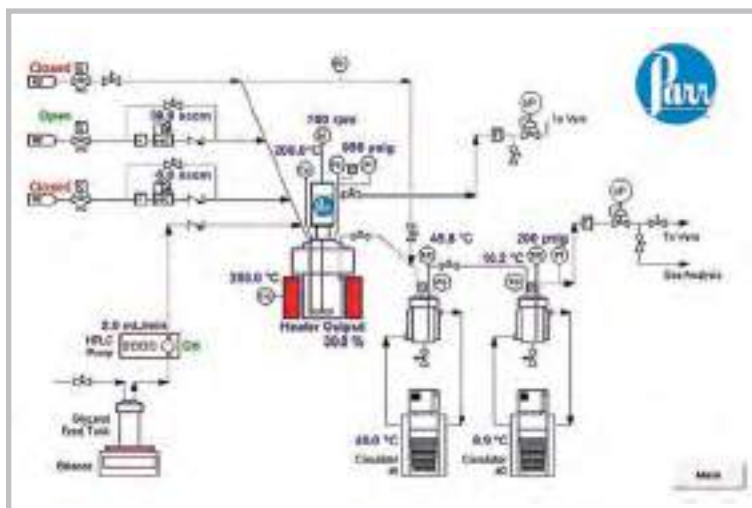

Process Flow Diagram for stirred reactor system.

The digital inputs can be logic inputs or contact closures. These are typically used for sensing valve positions or conditions of safety devices. Each digital input module provides for sixteen separate inputs.

*Continued next page >*

# 4871 Process Controller

< Continued from previous page

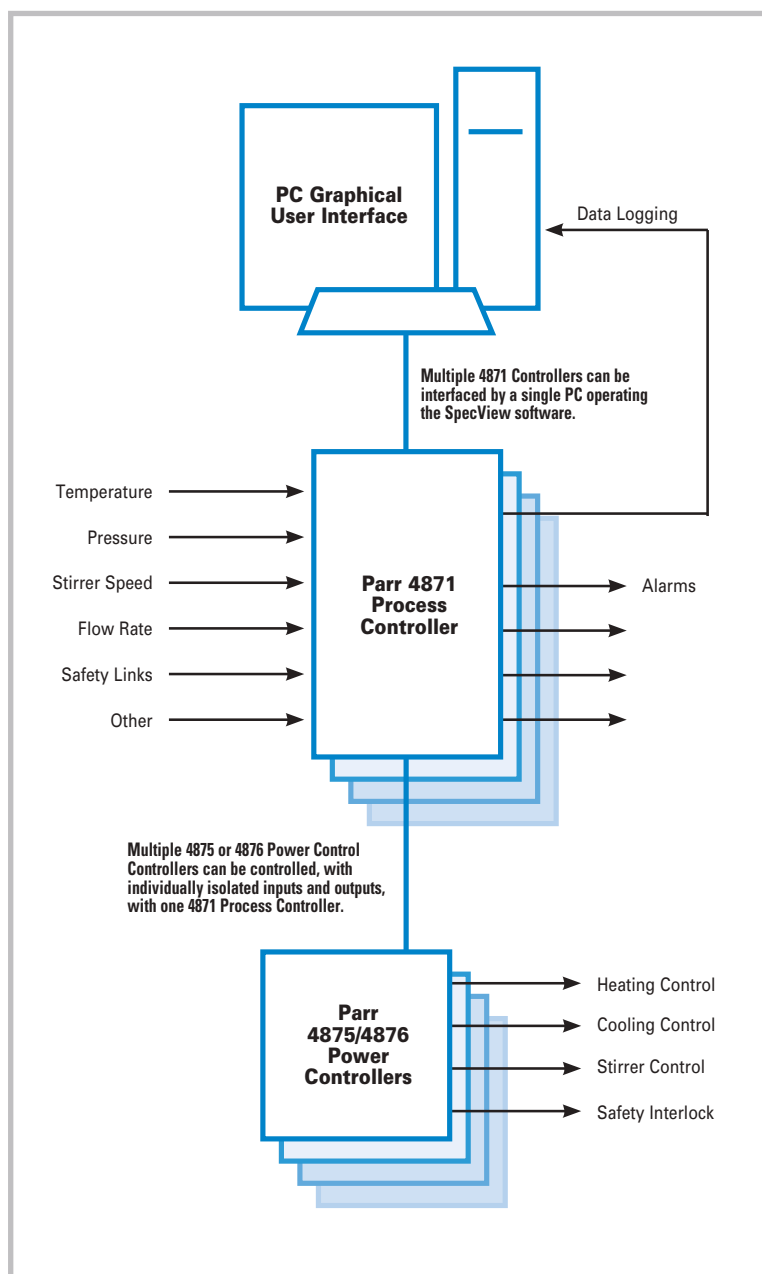

4871 Process Controller Input/Output Diagram.

## Output Modules

The analog outputs are 0-20 mA. A suitable dropping resistor can be used to convert this to 0-5 or 0-10 VDC. Analog outputs are commonly used to set stirrer motor operating speeds, position control valves, or drive mass flow controllers or pumps. Each analog output module is capable of controlling four separate devices or functions.

The digital outputs are open collector type capable of sinking up to 300 mA. They are commonly used to control heaters, solenoid valves for cooling or other flow control, system safety shut down, visual and/or audible alarms, and similar devices. Each digital output module is capable of controlling sixteen separate devices or functions.

## Control Loops

The controller can provide any number of PID or ON/OFF control loops, limited solely by the available CPU memory.

The PID control algorithm includes auto-tuning and fuzzy logic overshoot suppression for each control loop. For heating and cooling control, the PID control loops provide time proportioning of the associated digital output.

Many temperature control applications utilize two separate time proportioning outputs with one PID controller; one for heating and one for cooling.

Control loops can be linked together to provide cascade, feed forward or ratio control for difficult or advanced control applications.

Both high and low limit values can be entered for each control loop to sound alarms or initiate safety control schemes.

## The 4871 Process Controller combines the following components into a single control system:

### Control Module:

- Honeywell HC900 Hybrid Controller

### Flexible, Powerful Software:

- SpecView SCADA software
- System set up with graphical user interface configured to individual requirements

### Power Controller:

- 4875 or 4876 Power Controllers for handling heating, cooling, safety, and motor control devices



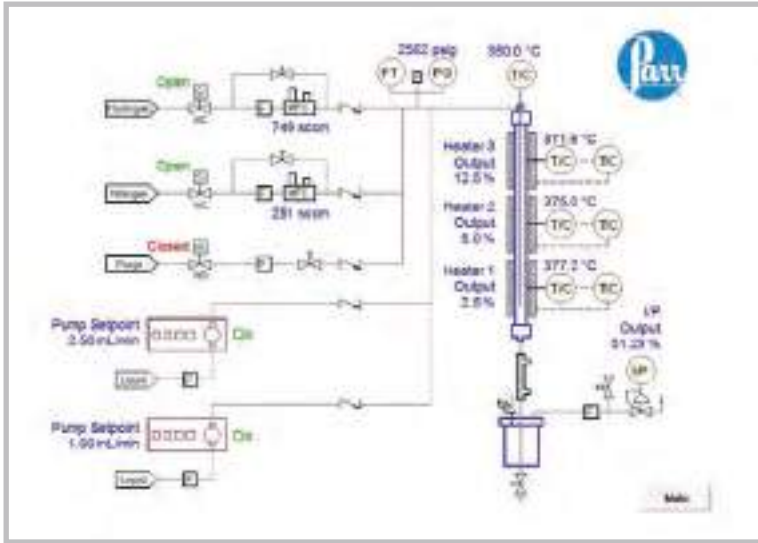

Process Flow Diagram for a tubular reactor with real-time process renderings.

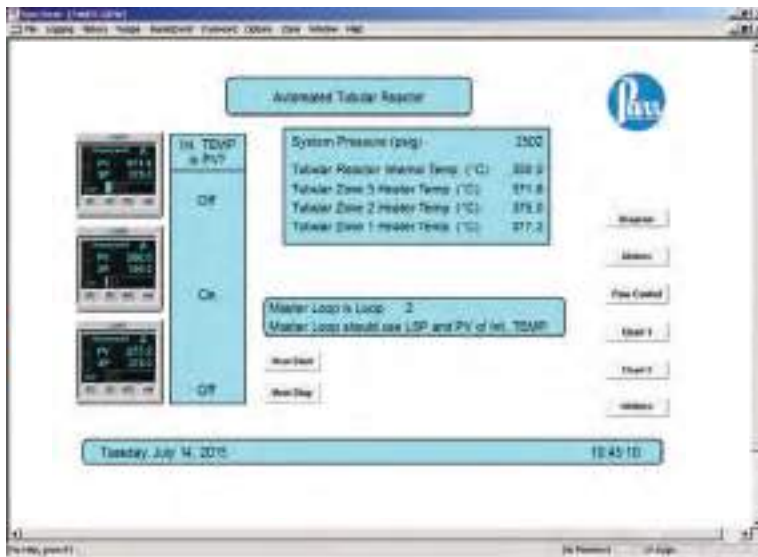

Screenshot of a 4871 Controller user interface for automated control of a tubular reactor system.

**4871 Dimensions**

Model	Width, in.	Height, in.	Depth, in.
4871A	12.86	15.12	11.00
4871B	16.98	21.56	13.00
4871C	29.78	21.56	13.00

**Set Point Programming**

Ramp/Soak profiles for controlling the entire process of a reactor can be written using the set point profiler incorporated into the control firmware. A single profile may be from 2 to 50 segments in length.

A typical profile might be a ramp and soak of the reactor temperature but, in addition, the analog and digital outputs can be tied to the basic profile to start and stop flows, activate stirrers or accessories, or change alarms. Any of the set points within the profile can be protected with the set point guarantee function that assures that the process variable will be within the entered limits before the profile can proceed.

The number of set point profiles is limited by the amount of available memory in the controller CPU. Typically, at least eight separate profiles can be running simultaneously. For example, eight reactors can be running a unique program at the same time.

While a maximum of 99 profiles can be stored in the controller itself, an unlimited number can be stored in the operator’s PC for rapid transfer to the controller.

In addition to the set point profiling capability, the controller is also equipped with a set point scheduling function. This feature can operate up to 8 profiles operating on a common time base.

**The 4871 Controller includes Operational Sequence Control**

The sequence control function offered by the 4871 Controller greatly expands the capabilities of this control for users who wish to control reactor systems. The operation of valves, pumps and other peripheral devices can be programmed on either a time or an event driven basis. Sequences can be very simple timed events or they can be very complex with multiple nested default sequences programmed to occur only if process feedback indicates a need to take alternative actions.

**Communications Channels**

Each 4871 Controller is equipped with an RS-485 and Ethernet communication ports. The RS-485 port is used for initial configuration and communications setup. The Ethernet port provides communication with the host PC when using the SpecView GUI program. Multiple controllers, each with a unique address, can be networked on the Ethernet interface with a single connection to the PC.

The principal advantage of the Ethernet interface is that it allows the user to use an existing network infrastructure to connect the controller to the PC. As a result, one can operate the controller over the network from anywhere within your facility.

*Continued on next page >*

## 4871 Process Controller

< Continued from previous page

Additionally, internet access from remote locations becomes possible. This type of connectivity offers unique possibilities, for example, related to remote diagnostics and system troubleshooting.

### Three Models Available

Parr 4871 Process Controllers are available in three different models to cover a wide range of applications. The 4871A will accept four I/O modules (typically up to 36 inputs and outputs). The 4871B will accept up to eight I/O modules, and the 4871C will accept up to twelve I/O modules. If more than 100 inputs and outputs are required, multiple controllers can be linked.

### SpecView SCADA Software

SpecView describes their product as "Software for people with other jobs". That seems to be an excellent description of this software package used with the 4871 Controller to:

- Interface with the control package
- Develop the graphical screen layout
- Establish the data logging profiles
- Prepare custom reports
- Create bar graphs
- Generate time trend graphs
- Monitor alarms
- Create flexible recipes
- Retrieve and replace logged data
- Operate the reactor system(s).

The full software package, not just a run-time version, is supplied with the 4871 Controller so operators can enhance their system as their needs change or expand/change their applications. Download a demo at [www.specview.com](http://www.specview.com).

### Graphical User Interface

An integral part of the Honeywell Controller is the hybrid control designer software. This is the "Drag and Drop" software that enables Parr to rapidly establish the controller's internal logic and adapt it to individual systems requirements.

The user can employ this same software to change or enhance the fundamental logic of the controller as additional components are added to the system or as functions need to change.

### Current Industrial Standards

Modbus, Ethernet, auto-tuning, fuzzy logic, auto-configuring Man Machine Interface (MMI), supervisory control and data acquisition (SCADA), multi-loop control; these are a few of the terms and capabilities designed into the hardware and software incorporated into the Parr 4871 controller.

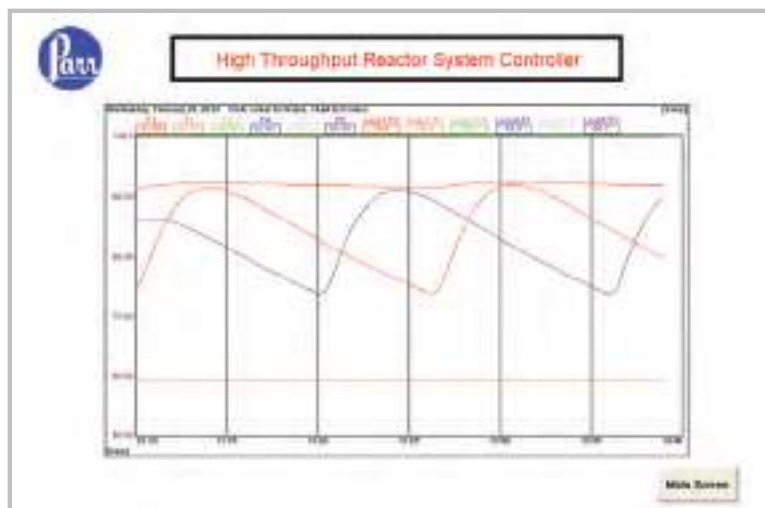

Screenshot from remote PC showing logged data in Data Logging Mode.

This modern and powerful package enables Parr to configure and build turnkey systems within weeks of order at very attractive prices.

### PC Requirements

In most laboratory and pilot plant applications, a PC will be used for the operator interface. A touch screen interface is also available. For plant or production applications, an industrial type user interface box with a color graphic LCD is available.

The PC used with the 4871 serves several functions. It is the operator's user interface for controlling the process. It also logs all of the operating data generated during a process run. It can also store multiple setups for rapid transfer to the 4871 Process CPU.

Any modern PC with current Windows operating system can be used with these controllers.

It is important to note that the control of the process always resides within the 4871 Controller, and not in the PC itself.

## 4871 Ordering Guide

Each 4871 Controller will be specified and assembled to match the user's intended application. These applications can vary from a single reactor with full process control to eight reactors operating in parallel. The 4871 Process Controller connects to a customer-supplied PC with a current Windows Operating System.

Please contact a Parr Customer Service Representative to discuss configuring a 4871 Process Controller to your specific application.

**Please contact a Parr Customer Service Representative to discuss configuring a 4871 Process Controller to your specific application.**

# 4871 Accessories



The 4875 Power Controller module is flexible and can be used in remote locations from the system being controlled.

## Power Controllers

Parr designs, builds and furnishes power controllers to adapt the analog and digital outputs from the 4871 Controllers to the reactors or systems being controlled. These power controllers handle all of the high current power circuits so that the control circuitry is isolated from these loads. This also makes it possible to install the controller in a control room some distance from the system being controlled.



4876 Power Controller



4875 Power Controller back panel for 230V model.



Back panel for 4876 Power Controller

### 4875 Power Controller

The power controller(s) will be designed for each individual system, but as an example, a 4875 Power Controller includes:

1. A solid-state relay sized to handle the current drawn by the vessel heater. This is commonly a 25-amp relay with its protective fuses.
2. A solid-state relay sized to drive a solenoid valve to control the flow of cooling water to the vessel.
3. A motor speed controller that converts the analog output signal from the controller to the electrical signal required to drive the specific stirrer motor. A circuit breaker for the motor is also provided.
4. A lockout relay to shut down the heater circuit should an alarm condition be detected.
5. Status lights for the principal functions.
6. Connections of appropriate style for the power input and device outputs.

### 4875 Dimensions

Model	Width, in.	Height, in.	Depth, in.
4875	9.40	5.00	10.50

### 4876 Power Controller

The 4876 Power Controller is equipped with three solid state relays, three lockout relays, and a single motor control. It is used with the 4871 to control up to three separate heaters and one motor. It can only be used in 230V systems.

### 4876A Power Controller

The 4876A Power Controller is the same as the 4876 described above but without motor control capability.

### 4876 Dimensions

Model	Width, in.	Height, in.	Depth, in.
4876	16.18	4.98	13.00
4876A	9.40	5.00	10.50

# Additional Controllers

## 4877 Valve Controller

The 4877 Valve Controller is used with the 4871 Process Controller to remotely actuate valves. It requires a dry air supply.

4877 Dimensions			
Model	Width, in.	Height, in.	Depth, in.
4877 (1-4 valves)	15.00	5.00	16.00
4877 (5-8 valves)	19.00	5.00	16.00
4877 (9-12 valves)	24.00	5.00	16.00



## A2200E Flow Controller Interface

The A2200E Flow Controller Interface can be used to send a set point and receive flow rate information from up to four MFCs. It is a basic control box for use with distributed control systems. Users needing more advanced features like PC communication and totalization should consider our 4871 Process Controller.

A2200E Dimensions			
Model	Width, in.	Height, in.	Depth, in.
A2200E	9.40	5.00	10.50



## A2110E Motor Controller

The A2110E Motor Controller is a stand alone box which can be used for a single motor. It may be equipped with a Motor Control Module expansion for setpoint control of RPM. A version of this controller with 4-20mA I/O capability for integration into existing systems is available.

A2110E Dimensions			
Model	Width, in.	Height, in.	Depth, in.
A2110E	9.00	4.64	13.00



**Series 5000 Multi Reactor System (MRS):** a six station multi-reactor system. Each reactor is equipped with it's own constant pressure gas delivery system. The 4871 Controller maintains all of the important system parameters, including temperature and stirring speed, and records the gas consumption of each of the reactors.



This custom order is set up to run sixteen reactors, two 4871 Process Controllers, with sixteen 4875 Power Controllers all through one PC.

# Optional Accessories **Chapter 7**



Inside This Chapter You Will Find:

[Heaters](#)

[Stirrer Motors and Drives](#)

[Stirrer Options](#)

[Gas Entrainment](#)

[Catalyst Baskets](#)

[Condensers](#)

[Safety Rupture Discs](#)

[Pressure Relief Valves](#)

[Pressure Gages](#)

[Gas Measurement Systems](#)

[Liquid Charging Systems](#)

[Solids/Slurry Addition Devices](#)

[Cooling Coils](#)

[Liners](#)

[Liquid Sampling](#)

[Catalyst Testing System](#)

[Bottom Drain Valves](#)

[Valves and Fittings](#)

[Pressure Hoses](#)

[Thermocouples](#)

[Equipment For Use In Potentially  
Ignitable Atmospheres](#)

[Windows](#)

[Insulated Electrical Glands](#)

[Spare Parts Kits](#)

[Temperature Limits](#)

[External Valves and Fittings](#)

# Heaters

## Standard Heaters

Parr has designed standard electrical heaters for all of the reactors in our product line. Different types of heaters are used for individual reactors to best meet the operational needs, heating load, and expected operating temperatures. The standard heater type and power rating for each reactor model is listed in the reactor specification tables.



### Ceramic Heaters

These are special purpose heaters with an electric element embedded in a shaped ceramic body which is held within an insulated metal housing. They are used for reactors designed for temperatures to 600 °C and for large multi-zone heaters.



### Calrod-Type Sheathed Element Heaters

These are rugged heaters with Calrod-type elements held within a metal shell. They are used for medium to large reactors for operating temperatures to 350 °C. In some cases the heater shell itself forms a part of the reactor support. An advantage of Calrod heaters is that the heating elements are easily replaceable.



### Rigid Heating Mantles

These are quartz fabric mantles housed in aluminum shells. They are used for moderate sized reactors in designs where the heater can be moved on or off the vessel. They are light weight and easy to handle, but they are not used to support the weight of the vessel and they are generally limited to operating temperatures of 350 °C or less.

## Optional and Custom Heaters

Parr offers a variety of heater designs which can be substituted for the standard heater normally furnished with each reactor. Most of these can also be used with Parr non-stirred pressure vessels as well.



### Clamp-On Band Heaters

These are normally used for very small reactors where maximum watt densities and heat transfer are required due to the limited surface area available on the vessel.



### Aluminum Block Heaters

Aluminum block heaters are available as an option for vessels of two gallons or less. These heaters are machined from solid blocks of aluminum with heater wells machined into the walls

of the block. Optional cooling channels are also available.

Aluminum block heaters have distinct features that make them desirable for certain applications. When compared to a circulating jacket, they offer the convenience of direct electric heat control as well as no plumbing requirements for hot oil. The heating elements, cooling channels, and associated wiring are embedded within the machined aluminum enclosure. This allows for even heat distribution, physical isolation of the electrical connections, and rapid cooling when needed. These attributes, in combination with a surface temperature

limiting device and proper external wiring, have allowed these heaters to be used in some potentially ignitable atmospheres (Hazardous Locations). Having integral machined cooling channels, aluminum block heaters have also been used for control of some exothermic reactions when internal cooling is not available.



### Flexible Heating Mantles

These can be furnished for many different applications. These are similar to our rigid type heating mantles except they are not held in an aluminum housing. They have a flexible fabric outer case for electrical and thermal insulation. This type of mantle is particularly useful for heating vessels with irregular shapes, such as those with windows in the cylinder wall, since they are flexible and can be split and laced onto a vessel around any external protrusion. As with rigid mantles, they will produce temperatures up to 350 °C, but they are limited to watt densities of 10 watts per square inch. This type of heater can be made to cover any of the vessels offered by Parr, and they are sometimes preferred when only moderate temperatures are required. Since they are constructed of cloth, an electrical ground wire cannot be provided.



### Circulation Jackets

A jacket can be welded to the outer wall of most Parr pressure vessels to provide a means for heating or cooling the vessel with a hot or cold liquid or steam. This type of heating is ideal for users who want to duplicate plant operating conditions, using a jacketed reactor comparable to jacketed equipment used in their plant. Since there are no electrical components in a jacket, and since the maximum temperature can be controlled by controlling the temperature of the heating medium, a jacketed vessel may be a good option for use in hazardous atmospheres.

Rapid and uniform heating can be attained with a jacketed vessel since the heating medium is in direct contact with the vessel. By controlling the temperature of the heating medium, temperature overshoots can be avoided when working with sensitive materials. Standard jackets are designed for operating pressures up to 100 psig (7 bar) within the jacket. Higher pressure jackets can be provided if required.

# Stirrer Motors and Drives

## Torque vs. Stirring Speed

The standard, open-type, variable speed motor installed on each Parr reactor will produce stirring speeds from zero to between 600 and 800 rpm with a torque adequate to drive the installed impellers in average viscosity mixtures. Higher horsepower motors and special stirrers can be provided for higher viscosities. Alternate drive pulleys are available to produce higher stirring speeds, but several basic rules must be considered when changing any of these components.

The highest torque from any motor is obtained at lower stirring speeds. Increasing the stirring speed reduces the torque in inverse proportion to the

speed. For operations involving high viscosity mixtures, the motor size, the type of impeller and the stirring speed must be matched to provide an effective mixing system.

As a general rule, the magnetic coupling installed on each Parr reactor will have a torque rating considerably higher than the torque obtainable from the motors offered for use with that apparatus. The goal is to make the motor the weak link so that the magnetic stirrer will be protected. Reference torque rating for applicable magnetic drive.

## Explosion-proof Motors

Explosion-proof motors designed for Class I, Groups C and D and Class II, Groups F and G with variable speed control can be

furnished for most Parr reactors.

## Flameproof “d” Motors

ATEX certified AC Flameproof Motors designed for use with group IIC gases are available for all of Parr’s stirred reactors. These inverter duty motors are available with simple variable frequency drives for control of the stirring speed. Please consult Parr for any specific ATEX certification related requirements.

## Air Motors

Air-driven motors can be installed on most reactors. The horsepower rating, torque, and available speed are all dependent upon the pressure and available volume of the driving air source. Maximum torques are delivered at relatively slow speeds and maximum horsepower is delivered at high speed.

### Stirrer Drive Motors

Motor Designation	HP (kW) Rating	Hazardous Location*	Variable Speed	Type	Standard Pulley		Optional Pulley	
					Max Speed, RPM**	Max Torque, in-lb	Max Speed, RPM**	Max Torque, in-lb
-VS.12	1/16 (0.05)	No	Yes	PMDC	600	6.75	1700	2.25
-VS.25	1/4 (0.18)	No	Yes	PMDC	600	27	1700	9
-XP.25	1/4 (0.18)	Class I, Div. 1 & 2 Groups C & D, E & F	Yes	PMDC	600	27	1700	9
-XP.25X	1/4 (0.18)	Ex 2G de IIC T4	Yes	Inverter Duty Constant Torque AC	450	33	1350	11
-AM.25**	1/4 (0.18)***	Ex II 2 GD c T4	Yes	Air	1000***	30	—	—
-VS.50	1/2 (0.37)	No	Yes	PMDC	600	54	1700	18
-XP.50	1/2 (0.37)	Class I, Div. 1 & 2 Groups C & D, E & F	Yes	PMDC	600	54	1700	18
-XP.50X	1/2 (0.37)	Ex 2G Ex de IIC T4	Yes	Inverter Duty Constant Torque AC	450	66	1350	22
-AM.50**	1/2 (0.37)***	Ex II 2 GD c T4	Yes	Air	1000***	66***	—	—
-VS.75	3/4 (0.55)	No	Yes	PMDC	600	81	1700	27
-XP.75	3/4 (0.55)	Class I, Div. 1 & 2 Groups C & D, E & F	Yes	Yes	600	81	1700	27

Values represented are nominal.

\*For more information on Hazardous Locations information see Tech Note 230.

\*\*Maximum speed values based on “no load”

\*\*\*HP, RPM, and torque values for air motors are based on a 40 psi supply capable of 34 cfm for the AM.50 and 10 cfm for the AM.25.



### Gear Box Torques

Motor HP Rating	3:1 Gear Box		5:1 Gear Box		10:1 Gear Box	
	Max Speed, RPM	Max Torque, in-lb	Max Speed, RPM	Max Torque, in-lb	Max Speed, RPM	Max Torque, in-lb
1/4	600	27	360	45	180	90
1/2	600	54	360	90	180	180
3/4	600	81	360	135	Not Recommended	

Contact Parr for ATEX Gear Box.

### Geared, Direct Drive Motors

A geared, direct drive motor can be installed on most fixed head floor stand reactors. This is an attractive arrangement for handling heavy stirring loads.

Any 1/4 hp or larger, variable-speed standard or explosion-proof motor can be used. Gear box drives are available with ratios of 3:1, 5:1 and 10:1. The 1700 rpm maximum speed will be reduced in an amount determined by the reduction ratio of the gear box, and the associated torque values from the table will be increased in the same ratio.

### Magnetic Drive

Description	Maximum Torque, in-lb
General Purpose	16
Footless General Purpose	16
Heavy Duty	60
Footless Heavy Duty	60
Extra Heavy Duty	120
Footless Extra Heavy Duty	120

**Parr Geared Drive Motor mounted on a Series 4553 Stirred Reactor System.**



# Stirrer Options

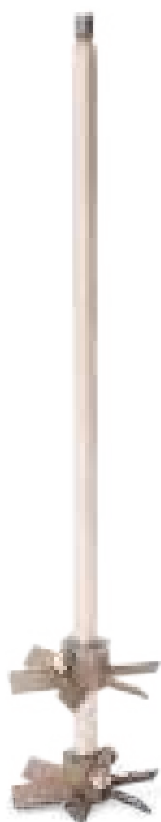

(1) Turbine Type Impeller



(2) Stamped Spiral Stirrer

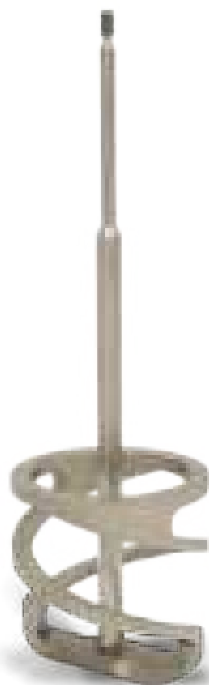

(3) Machined Spiral Stirrer



(4) Anchor Stirrer



(5) Paddle Type Anchor

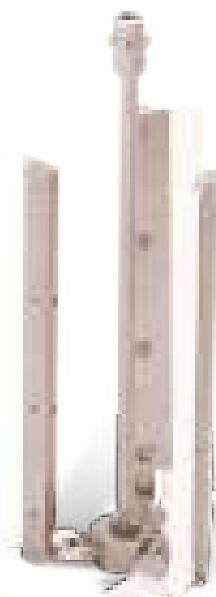

(6) Anchor Stirrer with Wiper Blades

## Turbine Type Impellers (1)

Parr reactors are usually equipped with turbine type impellers which produce an excellent mixing action over the range of stirring speeds at which these reactors typically operate. These impellers are made in four-blade and six-blade styles, with the smaller four-blade impellers used only on Micro and Mini Reactors. These impellers, for reactors with 300 mL volume or greater, may be positioned anywhere on the stirring shaft, with one impeller usually located near the bottom of the vessel to keep solids up in suspension and a second impeller positioned near the base of the vortex to pull reactant gases down into the liquid phase. These impellers generally provide excellent mixing for systems with effective viscosities up to approximately 25,000 centipoise (cP) with a 16 in-lb magnetic drive or up to 50,000 cP with 60 in-lb magnetic drive.

## Spiral Stirrers (2,3)

Spiral stirrers are offered in two styles: stamped and machined. The standard spiral stirrer includes blades constructed of stamped sheet metal and provides a cost-effective option. The more robust machined spiral stirrer is manufactured from a solid piece of bar stock which results in added strength and facilitates cleaning. Either of these spiral stirrers can be installed in any 1 liter, 2 liter or 1 gallon reactor to produce a positive downward thrust or upward thrust action when working with viscous polymers or other high viscosity mixtures. They work best in floor stand reactors with adjustable speed and heavy duty drive systems. Either left-hand (downward thrust) or right hand (upward thrust) spirals are available. The downward thrust spiral is generally preferred for heavy suspensions.

**Note:** All stirrer options may not be appropriate or available for each reactor size. Additional internal fittings may be required to adapt some stirrer styles to existing reactors in the field. Please contact the Parr Technical Service Department for assistance in selecting a stirrer suitable for the intended operating volume and viscosities.

## Anchor Stirrers (4-6)

Anchor stirrers are available in several configurations for use with moderate to high viscosity materials. This type of stirrer usually works best in vessels with an inside depth to diameter ratio of 1.5 to 1 or less. They are intended to operate at relatively slow speeds and generally require a heavy duty drive system capable of generating and delivering sufficient torque to the agitator. Footless magnetic drives work well with anchor or spiral stirrers.

Three basic types are offered:

- A U-shaped, flat bar anchor.
- A flat blade, paddle type anchor.
- A two-arm or three-arm, self centering anchor with PTFE wiper blades.

## Gas Entrainment Impellers

Parr offers a series of gas entrainment impellers for users who want to obtain maximum gas dispersion into a liquid system. This is obtained with a unique impeller attached to a hollow stirring shaft through which gases are continuously recirculated from the head space above the liquid through the impeller into the liquid phase. As with all impellers, the speed of the stirrer creates a vacuum at the tip of the impeller. Gas enters openings near the top of the shaft and is pulled through dispersion ports located at the tips of the impellers. In the Parr system with dispersion ports located at the very tips of the impellers, the higher the stirring speed — the higher the vacuum — and the higher the driving force for this very effective gas dispersion system.

When ordered with a new reactor, these impellers are offered as a complete package which includes the impeller, the hollow shaft with coupling, and any required foot bearings and brackets for the intended reaction. The baffles are a separate option which must be ordered individually.

The gas entrainment stirrers may be ordered as an optional stirrer when purchasing a new reactor system or

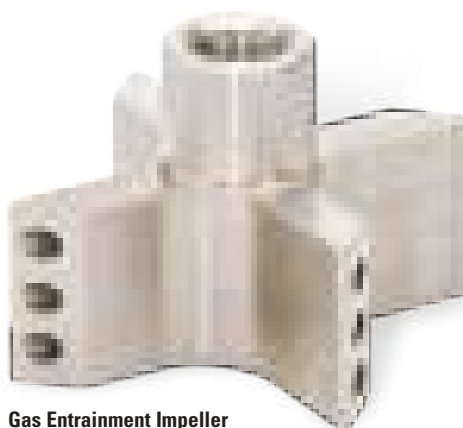

**Gas Entrainment Impeller**

easily installed in an existing system in the field. With the wide variety of reactor head styles and magnetic stirrers furnished on Parr reactors it is best to contact us with the numbers stamped on the head of your vessel so that we will be able to furnish the correct gas entrainment assembly for a particular reactor system.

Since these gas entrainment impellers operate best in the 1000-1200 rpm range, users will want to ensure that their stirrer drive system is set up to deliver these operating speeds; alternate pulleys and belts are available to convert existing reactor systems.

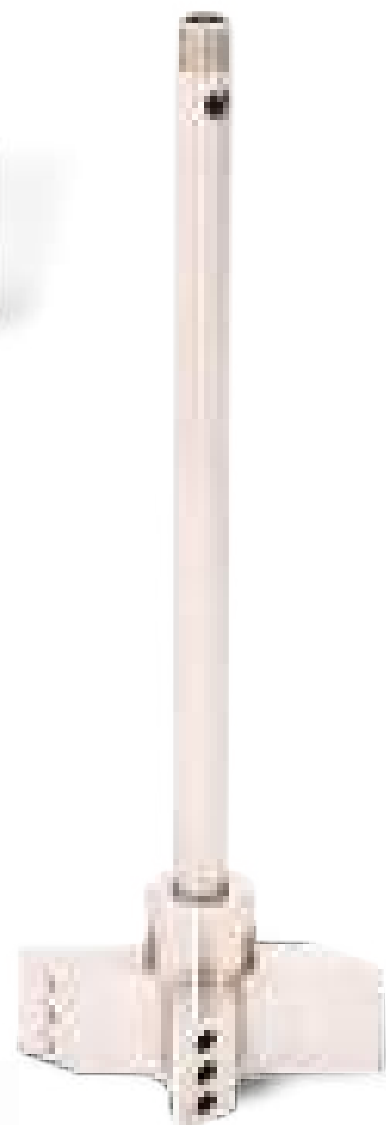

**Gas Entrainment Impeller with Hollow Shaft**

### Baffles

Because it is the relative speed of the tip of the impeller to the liquid phase that governs the mass transfer, baffles, which impede the rotation of the liquid with the impeller, can greatly enhance the operation of these gas entrainment impellers. While some natural baffling is provided by the internal thermowell, dip tube and cooling coils, the removable baffles are recommended for use with these gas entrainment impellers. These baffles may also be beneficial with the more traditional turbine type impellers for certain applications.



**Removable Baffle**

# Catalyst Baskets

**Catalyst baskets** can be provided for holding a supported catalyst so that it will not be destroyed or changed by the stirring action of the impeller. These can be installed in reactors with volumes ranging from 300 to 2000 mL. Two interchangeable styles are available. Special heads, internal cooling coils, thermowells and dip tubes are required to provide clear space in the vessel for these baskets.

## The Static Design

In the static design the mesh basket holding the catalyst remains stationary while impellers on the stirring shaft and baffles outside of the basket direct the flow of reactants over the surface of the contained catalyst. A unique gas entrainment impeller provides a uniform flow of both gas and liquid over the fixed catalyst bed held within the annular basket. The Parr design for these baskets includes a rigid bottom support which permits high speed stirring without excessive vibration. Cooling coils, internal temperature measurements, and liquid and gas sampling operations can be continued as usual without interference from the installed catalyst basket.

## The Dynamic Design

In the dynamic design the catalyst is held in an annular shaped, mesh basket which is attached to the stirrer drive in place of the stirring shaft. The rotating basket then serves as an impeller for stirring the reactants. Fixed baffles and coaxial

impellers ensure good circulation over the surface of the contained catalyst. The dynamic baskets are available for reactors with volumes of 1000, 1800, and 2000 mL. Dynamic baskets must be installed in reactors equipped with at least 1/4 hp motors to ensure that sufficient stirrer torque and speeds are available for proper operation. Dynamic baskets are interchangeable with static baskets in 1 liter and larger vessels.

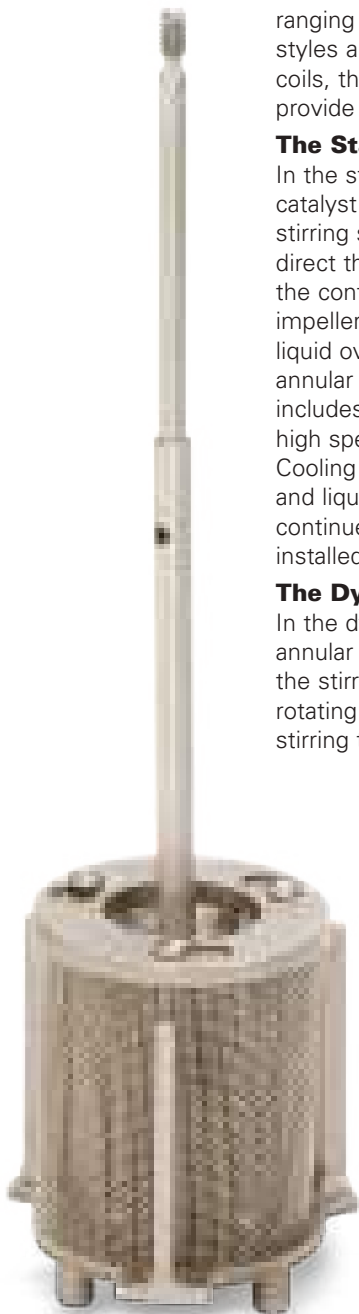

Catalyst Basket Static Design



Catalyst Basket Static Design with Uniflow Stirrer



Catalyst Basket Dynamic Design



# Condensers

Parr offers two styles of condensers for attachment to the head of a stirred reactor or pressure vessel. These can be made in various sizes to match the size of the reactor.

## Reflux Condenser

The reflux condenser consists of a length of tubing connected directly to the head of a vessel and equipped with a water cooling jacket. Condensed vapors are returned directly to the vessel and any non-condensable gases can be released through a needle valve at the top of the condenser. A helical insert in the condenser ensures maximum effectiveness in a rather short length.

## Reflux/Take-Off Condenser

The reflux/take-off condenser consists of the same water jacketed tube described above, assembled with a receiving vessel attached to the lower end of the condenser. Any vapor, such as water from a polymerization reaction, can be condensed and collected in the receiver, from which it can be withdrawn through a bottom valve. Any non-condensable gases can be released through a needle valve at the top of the condenser. If condensate

collection is not required, the receiver can be removed and the condenser can be mounted directly above the reactor for direct reflux into the vessel.

## Modifications

Many users opt to install a ball valve at the head of the reactor below the condenser to use as a shut-off to the condenser. Alternate collection vessel volumes are available upon request.

The installation of a condenser on any of the Parr reactors requires a larger port in the head of the vessel, the size of which will vary with the volume of the reactor system. Due to the limited space on the 4560 mini reactors, either the gage opening or one of the cooling coil ports can be enlarged to 1/4" NPT for use with a condenser. This modification would then either combine the gage and condenser functions or eliminate the internal cooling loop to accommodate the condenser. Reactors with volumes of 1 liter and greater would be modified with a 3/8" NPT opening or larger depending on the reactor volume. The standard head fittings would be rearranged to accommodate this port.



Condensers					
Reactor	Style	Note	Inner Tube O.D. Diameter, in.	Standard Receiver, mL	Part No.
4560 / 4590	Reflux/Take-off	Mod. Gage Opening 1/4" NPT	3/8	150	A2011HC
4560 / 4590	Reflux	Mod. Gage Opening 1/4" NPT	3/8		A2012HC
4560	Reflux/Take-off	Mod. Cool Coil Opening 1/4" NPT	3/8	150	A2013HC
4560	Reflux	Mod. Cool Coil Opening 1/4" NPT	3/8		A2014HC
4520 / 4530 / 4550	Reflux/Take-off	3/8" NPT	1/2	300	A2001HC
4520 / 4530 / 4550	Reflux	3/8" NPT	1/2		A2002HC
4530 HD*	Reflux/Take-Off	3/8" NPT	1/2	300	A2003HC
4530 HD*	Reflux	3/8" NPT	1/2		A2004HC
4540 / 4570 / 4580	Reflux/Take-off	3/8" NPT	3/8	300	A2016HC
4540 / 4570 / 4580	Reflux	3/8" NPT	3/8		A2017HC
4555	Reflux/Take-off	1/2" NPT	3/4	1000	A2018HC
4555	Reflux	1/2" NPT	3/4		A2019HC

\*with HD Magnetic Drive

# Safety Rupture Discs

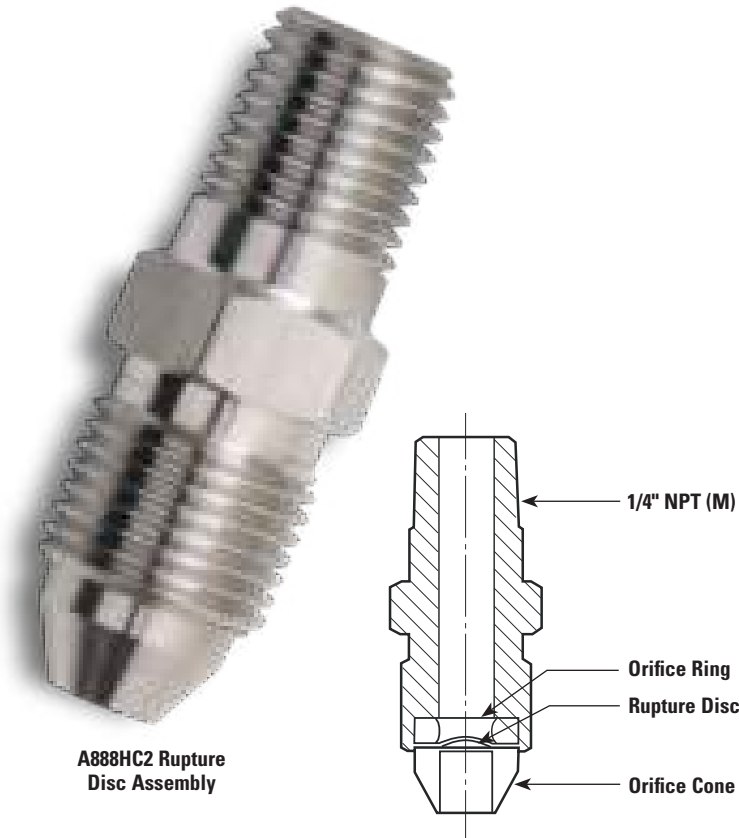

**A888HC2 Rupture Disc Assembly**

**Parr Pressure Vessels are protected** by custom built rupture discs. Examination of these discs will show that each of these discs is domed. This dome was produced at the factory by taking the individual disc to 70% of its burst pressure.

ASME as well as other pressure vessel codes dictate that pressure vessels must be equipped with a rupture disc designed to burst no higher than the design pressure of the vessel. For pressure loads that do not cycle rapidly such as in our vessels, we suggest limiting the actual

operating pressure to no more than 90% of the disc burst pressure. This combination will limit operating pressures to no more than 90% of the design pressure of the vessel in most cases.

We have selected Alloy 600 as the standard material for these rupture discs. It provides excellent corrosion resistance while retaining over 90% of its room temperature rating at temperatures up to 450 °C. For added corrosion resistance we can furnish these discs with gold facing or replace them with discs made of Alloy C-276. Discs can be produced to match any operating pressure and temperature above the stated minimums.

Parr reactors and pressure vessels from 25 mL to 2000 mL use the 526HC Series Alloy 600 disc or 581HC Series Alloy 600 with gold facing. The 1 gallon and larger use the 708HC series discs. The 4580 reactor systems use the 1415HC series discs.

In general, the 1000 psi disc in the 526HC/581HC series discs and the 800 psi in the 708HC are the lowest available ranges in the Alloy 600 material. Alternate disc materials are available but they do not offer the same corrosion resistant properties and temperature capabilities.

For applications where users prefer a lower range pressure gage, we would add a spring loaded relief valve set to protect the gage and a 1000 psi rupture disc as the fail safe protection.

## Safety Rupture Discs

Most rupture discs furnished by Parr come with CE certification. Upon request, Parr can furnish ½" discs with flat seat (both holder and rupture disc) with ASME certification markings and documentation (with UD certification designator).

Users are invited to contact the Parr Technical Support Staff with requirements for your rupture disc needs.

### Typical Rupture Discs for 1/4" Orifice

Burst Rating, psig	Inconel Disc	Gold-Faced Inconel Disc
1000	526HCPD	581HCPD
2000	526HCPF	581HCPF
3000	526HCPG	581HCPG
4000	526HCP40CT	581HCP40CT
5000	526HCPH	581HCPH
8000	526HCPJ	581HCPJ
10000	526HCP100CT	

### Typical Rupture Discs for 1/2" Orifice

Burst Rating, psig	Inconel Disc
1000	708HCP10CT
1500	708HCP15CT
2000	708HCP20CT
3000	708HCP30CT
3000	1415HCP30CT
4500	1415HCP45CT

*Note: For a complete list of rupture disc part numbers, burst ranges, materials, and temperature ratings, see manual 231M.*

# Pressure Relief Valves

**Spring-loaded relief valves** should be viewed as a supplement to and not a substitute for a safety rupture disc. The rupture disc is the primary means for protection of the operator and the vessel in case of accidental over-pressure. Spring-loaded relief valves can be added to a reactor or vessel to:

- Relieve pressures near the maximum operating pressure.
- Reseal once excess pressure has been relieved.
- Protect low pressure components at pressures below available rupture disc ranges.

The relief valves listed below can be installed on any Parr vessel. The relief valves are constructed of stainless steel and have FKM O-rings. Other valve and O-ring materials are available on special order. Relief valves with CE Certification are also available.



**A175VB Relief Valve**



**A140VB2 Relief Valve**

Pressure Relief Valves for Low Pressures				
Part No.	Preset psi	Adjustable psi	Bar	Discharge Connection
A140VB2PA	100	50-150	3.45-10.3	1/4" NPT (M)
A140VB2P1	150	50-150	3.45-10.3	1/4" NPT (M)
A140VB2P2	145	50-150	3.45-10.3	1/4" NPT (M)
A140VB2PB	200	150-350	10.3-24.1	1/4" NPT (M)
A140VB2PC	600	350-600	24.1-41.4	1/4" NPT (M)
A140VB2PD	300	150-350	10.3-24.1	1/4" NPT (M)

Pressure Relief Valves for High Pressures			
Part No.	Pressure Relief Range, psi	Bar	Discharge Connection
A175VB	750-1500	52-103	1/4" NPT (F)
A175VB2	1500-2250	103-155	1/4" NPT (F)
A175VB3	2250-3000	155-207	1/4" NPT (F)
A175VB4	3000-4000	207-276	1/4" NPT (F)
A175VB5	4000-5000	276-345	1/4" NPT (F)
A175VB7	350-750	24-52	1/4" NPT (F)
A175VB8	50-350	3.4-24.1	1/4" NPT (F)

\* Note: When ordering any of the above relief valves, the user may specify a desired set pressure.

# Gages



**593HCPF Gage 3-1/2" Dia.**



**56HCPF Gage 4-1/2" Dia.**



**2633HCP10AD 3-1/2" Back Mount Gage**

**Gages for Parr pressure vessels** can be furnished with either 3-1/2" or 4-1/2" dials in any of the ranges shown in the table below. All have stainless steel Bourdon tubes and 1/4" NPT male connections.

Alloy 400 gages are available on special order. Accuracy is 1.0 percent of full scale for the 4-1/2" size and 1 percent for the 3-1/2" gages. All standard gages include dual scales, with graduations in both pounds per

square inch (psi) and bar. Gages in Pascal units are available on special order. Compound gages which show vacuum to 30 inches of Mercury and positive pressures to 300 psi (20 bar) are also available.

When ordering a special gage, specify the gage diameter, the desired range and scale units.

The gage on a pressure vessel should be 150 percent of the maximum operating pressure. This allows the gage to operate in the most accurate pressure range and prevents the gage from being stressed repeatedly to its full range, which will effect the calibration.

Gages				
Pressure, psi	Range, bar	4-1/2" Dia. Gage No.	3-1/2" Dia. Gage No.	3-1/2" Dia. Back Mount Gage No.
0-100	0-7	56HCPA	593HCP1AD	2633HCP1AD
0-200	0-14	56HCPB	593HCP2AD	2633HCP2AD
0-600	0-40	56HCPC	593HCP6AD	2633HCP6AD
0-1000	0-69	56HCPD	593HCPD	2633HCP10AD
0-2000	0-138	56HCPF	593HCPF	2633HCP20AD
0-3000	0-207	56HCG	593HCPG	2633HCP30AD
0-4000	0-275	N/A	593HCP40AD	N/A
0-5000	0-345	56HCPH	593HCP50AD	2633HCP50AD
0-7500	0-517	56HCP75AD	N/A	2633HCP75AD
0-10000	0-690	56HCPK	593HCPK	N/A
30" Hg Vac/300 psi		56HCP3YB	593HCP3YB	2633HCP3YB

Parr's standard stainless steel reactor gages are typically manufactured to meet ASME/ANSI B40.1 Grade A accuracy specifications.

# Gas Measurement Systems

**Parr offers a variety of accessories** for its line of pressure reaction vessels to enable the investigator to accurately determine the amount of gas consumed in a reaction conducted at elevated pressures and temperatures. There are essentially two methods used to measure the amount of gas delivered to a reaction vessel. These are:

1. The measurement of the pressure drop in an auxiliary supply vessel of known volume.
2. The measurement and integration of the flow rates using an electronic mass flow meter.

Each of these methods has its advantages and limitations as discussed below.

## Intermediate Supply Tanks

Certainly the simplest method to measure the amount of gas consumed in a reaction is to feed the gas from a vessel of known volume and to measure the pressure drop in this vessel during the course of the reaction. The consideration in this method is to select a supply vessel with a volume matched to the amount of gas that will be consumed in the reaction. It needs to be large enough to contain enough gas to complete the reaction and small enough that the pressure drop will be significant and measurable. This basic technique can be applied in a number of ways:

1. The supply tank can be connected directly to the reaction vessel. This is the simplest and least expensive. The principal limitation of this approach is that the reaction pressure will fall as gas is consumed and the reaction will not be conducted at a constant pressure.
2. The supply tank can be fitted with a constant pressure regulator. The regulator must be selected to match the planned operating pressure. This regulator will deliver gas to the reaction vessel at constant pressure overcoming the limitation described in (1) above.
3. Initial and final pressures in the supply tank can be measured with analog gages, or continuous pressure readings can be made and recorded using pressure transducers. While the transducers add cost, they also add increased resolution and the opportunity to follow the rate of the pressure drop and hence the rate of reaction.
4. Enhanced precision can be achieved by measuring the temperature in the supply tank and applying corrections as appropriate.

Parr offers a series of high pressure burettes in complete packages for direct connection to our reactors. The basic ones are listed on the following page.

These burettes can also be equipped with digital pressure transducers, internal thermocouples and data acquisition and reduction support. Please contact our customer support group for information on these possibilities.

## Mass Flow

Parr Instrument Company can provide mass flow meters or controllers for quantitative mass flow based analysis. Mass flow controllers are mass flow meters that incorporate an integral control valve, external valve, or feed pump to control

the fluid flow. Mass flow controllers are typically used in automated or semi-automated systems. Due to many application and calibration specific requirements, please contact Parr Instrument Company for technical assistance with mass flow meters or controllers.

Parr offers multiple, price driven, electronic interface devices for mass flow meters and controllers. The Parr A2200E Mass Flow Meter/Controller interface system offers a manually operated readout and/or set point module for up to four mass flow meters/controllers. When the A2200E is used with a mass flow controller, a manually operated back pressure regulator is required. The Parr 4871 Process Controller offers remote set point, readout, data logging, totalizing, gas mixing, and process related interfaces with these mass flow devices. Other intermediate interfaces can be provided.

## High Pressure Gas Burettes

Parr offers a series of high pressure burettes intended to introduce gas (commonly hydrogen) to a reactor at a constant pressure. The burettes consist of a high pressure reservoir equipped with an inlet valve, a pressure gage and a relief valve. A constant pressure regulator with a check valve, a connecting hose and a support stand are included with each pipette.

The amount of gas consumed in a reaction can be determined by knowing the volume of the high pressure reservoir and observing the pressure drop in the reservoir during a reaction.



**Series 2280 High Pressure Gas Burette**



Parr high pressure burettes can be furnished in various sizes as shown in the adjoining table, each with a regulator to deliver gas to the reactor over the designated pressure range. The moles of gas shown in the table represent the amount of hydrogen that will be held in the burette at the maximum pressure. The deliverable volume will be a function of the difference in pressure between the pipette and the reactor. The size of the burette selected should be large enough to provide sufficient gas to complete the reaction while still maintaining sufficient pressure in the burette to force gas into the reactor.

Reservoirs with larger volumes are available as are regulators with different delivery ranges. Modifications can be made to these basic systems to add an internal thermocouple to the reservoir and/or a pressure transducer for digital readout and/or recording.

### Gas Burettes Sizing

Sample Cylinder Volume, mL	Maximum Pressure, psi	Moles of H <sub>2</sub>	Maximum Pressure (bar) For CE (TPED) Applications	Moles of H <sub>2</sub> For CE (TPED) Applications
150	1800	0.6	100	0.5
300		1.3		1.1
500		2.3		1.8
1000		4.6		3.7
2250		10.4		8.5
150	5000	1.7	300	1.5
300		3.4		3.0
500		5.7		5.0

## Liquid Charging Systems

### Liquid Metering Pumps

Liquid metering pumps are commonly used to introduce liquids into a reactor or vessel at elevated pressures on a continuous basis. A wide variety of pumps are available to meet various pressure, flow, and control requirements. The pumps listed here cover some of the more common pressure and flow requirements associated with Parr reactors and pressure vessels. The pumps described under these catalog numbers include an inlet filter, a reverse-flow check valve and the outlet tubing to the reactor. Special pumps can be furnished to meet requirements outside the range of these pumps. All pumps can be operated from their faceplates and all except the 2312E can also be remotely controlled with a 0-10VDC analog signal, such as from the Model 4871 Process Controller.

### Liquid Metering Pumps

Part No.	Flow Rate, mL/min	Pressure, Max. psi	Wetted Material	Digital Pressure Alarm / Shut-off
2312E	0.01-10	2000	PEEK	No
2313E	0.01-10	5000	Stainless	No
2314E	0.04-40	1500	Stainless	No
2315E	0.01-10	5000	Stainless	Yes
2316E	0.04-40	1500	Stainless	Yes

### Liquid Charging Pipettes

To introduce liquids into reactors or vessels at elevated pressures, the most economical way is to use a pressure pipette as a secondary vessel. These are often used for liquid addition to a batch process. Liquid is forced into the reactor from the pipette by applying gas pressure to the pipette greater than the pressure within the vessel. If the passages in the connecting line are large enough, slurries or catalyst suspensions can also be charged into the reactor in this manner.

The pipettes listed below offer a choice of volumes and are rated for pressures to 1800 psi. They include a nitrogen filling connection for attachment to a nitrogen tank. More elaborate pipette systems can be assembled to special order to include additional fittings, such as a pressure gage for the pipette, a pressure relief valve or a large opening ball valve. Special pipettes can also be furnished for higher pressures to 5000 psi.

### Liquid Charging Pipettes

Part No.	Pipette Volume, mL	Pressure Rating, psi
A2113HC3	50	1800
A2113HC4	150	1800
A2113HC	300	1800
A2113HC2	1000	1800



# Solids/Slurry Addition Devices

**One of the modifications most frequently requested** is a port or other means to feed liquids, solids, or slurries into the vessel without removing the head. This can be done in various ways.

## Solids Charging Port with Ball Valve

A ball valve with a 3/8" diameter opening can be installed on any one liter or larger vessel and used in conjunction with a high pressure pipette for injecting slurries under pressure. These are opened or closed with a quarter turn of the handle. Larger diameter valves are available for 1 gallon and larger vessels. These ball valves will withstand the full pressure developed in a reactor at moderate temperatures, but their pressure rating falls off rapidly at temperatures above 100 °C.



A143VB Ball Valve



A550HC Catalyst Addition Device

## Internal Catalyst Addition Device (ICAD)

Parr has developed a unique device for adding small amounts of solids (or liquids) from a sealed container held within a reactor. The ICAD is of particular interest to users performing kinetic studies of catalytic reactions. This device consists of a small cylindrical chamber with a cap that is sealed to the body with an O-ring. It attaches to the underside of the vessel head with a 1/8" NPT connection. To discharge the contents of the holder, gas pressure is applied through a valve installed on the top of the head. When the applied pressure is greater than the pressure within the reactor, the cap is forced open and the catalyst or other contents of the holder will be released into the reactor. This device works best in the taller, 450 mL and 600 mL Mini Reactors, and in the 1 liter and larger Parr Reactors.

## Solids Charging Ports

Part No.	Nominal Size	Orifice Diameter, in.
A143VB	1/4" NPT (F)	0.250
A132VB	3/8" NPT (F)	0.375
396VBAD	1/2" NPT (F)	0.406

## Internal Catalyst Addition Devices

Complete Reactor	Mounting Size, cc	Assembly No.	Thread
Mini	6	A550HC3	1/8" NPT
One Liter	8	A550HC	1/8" NPT
Larger	20	A550HC2	1/8" NPT

## Solids Charging Device

A solids charging device in the head of a reactor can serve as a convenient solids charging port at atmospheric pressure. The body of this device is machined with an internal taper to aid in the delivery of the solids into the vessel. It has a convenient screw cap closure with an FKM O-ring seal for use up to 225 °C. Other O-ring materials are available upon request, either for higher temperature operation or material compatibility.



Various views of Solids Charging Device with internal taper

## Solids Charging Devices & External Catalyst Addition Device (XCAD)

Reactor	Available Fitting Sizes
Mini	1/4" NPT (M)
1 & 2 Liter	3/8" NPT (M)
Gallon & up	1/2", 3/4", & 1" NPT (M)

## External Catalyst Addition Device (XCAD)

The addition of a specialized 5 mL or 10 mL chamber with a tools-free closure and two valves to the above solids charging device adds two important capabilities:

1. The chamber/valves assembly can be removed from the reactor without tools and filled in a glove box, for example, if an atmosphere-sensitive catalyst is being used.
2. Upon reattachment of the chamber/valves assembly to the reactor, a high pressure gas source can be connected to the top of the device to allow addition of catalyst to the reactor at elevated temperature and pressure.

Similar to the Internal Catalyst Addition Device (ICAD) shown above, the XCAD is ideal for kinetic studies, and is often paired with a gas burette ([page 126](#)) for constant pressure hydrogenation catalyst screening/characterization studies.



## Cooling Coils



Serpentine Cooling Coil 1000 mL



Spiral Cooling Coil 1000 mL

**Internal cooling coils** are available for all but the smallest Parr reactors. These coils provide an extremely effective means of removing heat from the vessel to control an exothermic reaction or for cooling the reactor at the end of a test. Since heat is transferred through the relatively thin wall of the coil instead of the thick wall of the vessel, cooling rates are generally much faster than heating rates; particularly at temperatures above 80 °C. Water is normally used as the cooling medium although compressed air can be used for modest cooling loads. Cooling coils are offered in three standard configurations:

**Single Loop** - Single loop coils consist of a vertical run of tubing formed into a "hairpin" shape. These are normally installed on small reactors where there is minimum space available.

**Serpentine Coils** - Serpentine coils consist of six to eight vertical runs of tubing uniformly spaced around the circumference of the vessel. These coils provide reasonable surface area, minimum interference with stirring patterns, a reasonable amount of baffling, and ease of cleaning and maintenance.

**Spiral Coils** - Spiral coils consist of multiple loops wound just inside the inside diameter of the vessel. They are normally available only for the 4" and 6" ID vessels although other sizes have been built on special order. They do maximize the cooling area available, but sometimes at the expense of uniform stirring and ease of cleaning. The individual reactor specifications will dictate the style of coil or coils available for each reactor. Cooling coils are available in the same choice of materials as the reactor bodies themselves. All cooling coils are removable. Plugs are available to close the openings in the head and in most cases these openings can be converted to alternate inlets/outlets if cooling is not required.

## Liners

**Removable, open top, cylindrical liners** made either of borosilicate glass or PTFE can be furnished to fit most Parr reactors and general purpose vessels. These liners slide into the cylinder and require no additional fittings, but they may not coordinate with some alternate accessories and stirrers. Although they will not keep corrosive vapors from reaching the surfaces of the cylinder and head, they make it much easier to add and remove liquid reactants, and they give some protection to the cylinder when working with corrosive solutions. It must be noted, however, that adding a PTFE liner will slow the heat transfer rate into and out of the vessel, and it may be necessary to adjust the temperature control method to prevent overheating.

Liners			
Fits ID, in.	Fits Cylinder Size, mL	Glass Liner Part No.	PTFE Liner Part No.
1.3	50	1431HC	1431HCHA
1.3	100	1431HC2	1431HC2HA
1.5	125	2920HC2	2920HC4HA
1.5	200	2920HC3	2920HC3HA
1.5	75	2920HC	2920HC2HA
2-1/2	250	762HC10	N/A
2-1/2	500	762HC2	762HC2HA
2-1/2	300	762HC	762HC4HA
2-1/2	450	762HC2	762HC5HA
2-1/2	600	762HC3	762HC6HA
2	100	762HC7	762HC7HA
2-1/2	160	762HC8	762HC8HA
3-1/4	600	2312HC	2312HC3HA
3-1/4	1200	2312HC2	2312HC4HA
3-3/4	1000	1441HC	1441HCHA
3-3/4	1800	1442HC	1442HCHA
4	1000	398HC	398HCHA
4	2000	399HC	399HCHA
6	1 Gallon	894HC	894HC4HA
6	2 Gallon	894HC2	894HC5HA



Glass Liners 2000 and 1000 mL Sizes  
Temperature Limit: 565 °C



PTFE Liners 2000 and 1000 mL Sizes  
Temperature Limit: 225-250 °C

# Liquid Sampling



## Sample Collection Vessel

A sample collection vessel can be added to most reactor systems. Designed to efficiently and safely allow for the withdrawal of liquid or vapor samples at elevated temperatures and pressures, this quick close, O-ring seal vessel has a volume of 5 mL or 10 mL and is designed for operating pressures to 3000 psi (200 bar).

The typical arrangement for this sample vessel includes a cooling sleeve, isolation and vent valves. A drain valve may also be added to the vessel.

The isolation valve is mounted at the head of this vessel and is used to seal the vessel once the sample is transferred. The vent valve is installed in a tee and is used to release

any residual pressure in the line between the sample valve and the sample vessel. Samples can be removed either by opening the collection vessel and pouring it out or by use of the drain valve.

Standard material of construction is T316 Stainless Steel but it can be provided in any of the other alloys if required. A high pressure 25 mL or 75 mL sample collection vessel without a cooling sleeve for pressures to 5000 psi is available upon request.

## Sample Collection Vessels

Part No.	Description
4351	Sample Collection vessel, 10 mL, with cooling sleeve, isolation & vent valves for connection to 1/8" NPT valves
4352	Sample Collection vessel, 10 mL, with cooling sleeve, isolation & vent valves for connection to 1/4" NPT valves
4353	Sample Collection vessel, 10 mL, with cooling sleeve, isolation & vent valves for connection to 3/8" NPT valves
-D	Optional Drain Valve



## 4878 Automated Liquid Sampler

A safe and reliable method for collecting multiple liquid samples from heated and pressurized reactors has been sought for many years. Parr Instrument Company is pleased to introduce the Parr 4878 Automated Liquid Sampler which can extract up to six liquid samples at a user-defined interval without the need for the continued presence of an operator. Controlled through a user-friendly touch screen, a series of precision switching valves allows collection and deposition of samples with consistent volumes into individual vials. The 4878 can operate up to the maximum working pressure of all standard Parr reactors and pressure vessels. A multi-step loop sequence ensures clearing of the reactor dip tube between samples to yield samples representative of the bulk reactor fluid.

### Features include:

- Touch screen controller with easy-to-navigate graphical displays
- Compact footprint 14-in wide x 16-in deep (35cm x 40cm)
- Stand alone design compatible with any new or existing Parr reactors and pressure vessels
- User-definable parameters including time between samples, number of samples, and number of loop sequences
- Various sample loop volumes available to accommodate a wide variety of sampling scenarios
- Capability to connect with mobile devices on both iOS and Android platforms
- Possible customizations include: design for use in hazardous locations, increased number of samples, special alloy components. Contact Parr Technical Service for additional options to fit your requirements.



## Filtered Dip Tubes

To assure you collect only liquid from a vessel, the solids must be removed. Parr recommends press-on filters, or in some instances screw-on filters, at the end of the dip tube to remove solids from the liquid sample. These sintered metal filters are available in a variety of materials, with a variety of nominal pore sizes, often from 0.5 microns to

40 microns. Most of these filters have a relatively small filtration area, so the user should consider how long it will take for a sample of desired volume, viscosity, and solids content to be collected in a sampling device. If clogging of a press-on filter is a possibility, Parr recommends purchasing a second easy-to-install complete filtered dip tube as the filters are factory-installed and not easily replaced in the field. Screw-on filters are field-replaceable and have a larger surface area, but due to their larger size usually only supplied for use with 1 Liter and larger vessels.

# Catalyst Testing System

## 2280 Burette, 4566 Reactor with 4848 Controller, and 4878 Automated Liquid Sampler

The recent introduction of Parr's 4878 Automated Liquid Sampler has allowed the construction of a complete system for activity/kinetic testing of catalysts in a high pressure, high temperature environment. In the system shown, a Parr 2280 Gas Burette with 50 mL reservoir delivers H<sub>2</sub> at a user-settable, constant pressure to a 4566 300 mL stirred reactor. Operation at up to 180 bar at up to 350 °C is possible. A Parr XCAD (eXternal Catalyst Addition Device) allows introduction of solid/powder catalyst to the liquid contents of the reactor **at reaction pressure and temperature**, setting t=0 for kinetic experiments. An included gas entrainment impeller provides for high speed three phase mixing. A Parr 4878 Automated

Liquid Sampler allows unattended collection of filtered liquid samples from the reactor at a user-defined interval for subsequent analysis.



## Bottom Drain Valves



A465VB Bottom Drain Valve

**Bottom drain valves can be added** to most Parr reactors. These valves are particularly useful for those working with polymers or other material that must be discharged from the reactor while they are still hot and before they can solidify. These valves are also quite useful for the 1 gallon and larger vessels which are too large to conveniently lift from the heater for product recovery. Bottom valves are rarely installed on the micro and mini reactors with their small volumes and light vessel weights.

The standard bottom drain valve has a rising stem, that is flush with the inside cylinder bottom so that there is no dead space between the bottom of the vessel and the shut off point of the valve. In the fully open position the stem is retracted completely to open a clear passage for draining the vessel.

When the valve is reclosed, any material in this passage will be pushed back into the reactor by the rising stem. Valves with 3/8" diameter clear passage are recommended for vessels with volumes from 1000 mL to 2 gallons. A 1/4" valve is available

for 600 mL and smaller vessels. High pressure and larger diameter valves are available where required.

These valves will withstand the full operating pressures and temperatures of the vessels in which they are installed in the closed position. They are available in all of the current Parr materials of construction. Users can also specify that a reactor ordered with a bottom valve shall have a tapered bottom so that it will drain easily through the valve opening.

Not all Parr reactors will accept a bottom drain valve. Since the valve extends approximately 8 inches below the bottom of the vessel, the entire vessel must be raised by this amount to accommodate the valve. This makes some models too tall for convenient bench top operation. The specification tables for each model will identify those reactors in which a bottom drain can be readily installed, and those which will not accept a bottom drain, or those which will require custom modification of the heater and support stand to accommodate a bottom valve.

### Needle Valves and Ball Valves

Needle valves and ball valves can also be installed as bottom outlet valves. Needle valves are generally used on the smaller reactors. While ball valves can be used for large discharge passages, they are generally limited in their operating temperature/pressure capabilities and they leave a fairly large dead space between the bottom of the vessel and the seat of the valve.

### Bottom Drain Valves

Part No.	Opening Dia., in.	Outlet Connection	Max. Press., psi	Max. Temp., °C	Seal
A485VB	0.20	1/4" NPT (F)	3000	225	PTFE
A485VB2	0.20	1/4" NPT (F)	3000	350	Silver
A485VB3	0.20	1/4" NPT (F)	3000	350	Silver
A465VB	0.34	3/8" NPT (F)	2000	350	Grafoil
A465VB2*	0.34	3/8" NPT (F)	2000	350	Grafoil
A465VB3	0.34	3/8" NPT (F)	2000	350	Silver
A177VB2	0.31	3/8" NPT (F)	5000	500	Silver
A296VB2	0.69	1" NPT (F)	1900	350	Silver

\* Set up for a Band Heater.

# Valves and Fittings

Parr stocks and can install a wide variety of valves and fittings for use with reactors and pressure vessels. These include:

- Needle Valves with NPT or tube connection.
- Regulating Valves with NPT or tube connection.
- Ball Valves with NPT or tube connection.
- High Pressure Valves
- Severe Service Valves
- Remote Operating Valves
- Tube Connectors
- Pipe Connectors
- Plugs
- Union Coupling Adapters

Please contact our customer service department for details.

## Manual Control Valves for Compressed Gas Tanks

Tank valves with couplings to fit standard compressed gas cylinders are available in stainless steel for corrosive gases and in nickel plated brass for non-corrosive gases. The brass valves have a 2-1/2" diameter pressure gage which shows the tank pressure. Both styles have a 1/4" NPT female outlet which will accept any pressure hose or gas tube assembly. These valves do not regulate the delivery pressure of the gas. Pressure regulators are available on special order.

### T303 Stainless Steel Valves-No Gage

Fits CGA Tank Valve No.	Outlet No.	Typical Usage
A120VBPN	510	Propane, butane, ethylene oxide
A120VBPP	660	Chlorine, sulfur dioxide, nitric oxide

### Nickel-Plated Brass Valves with Cylinder Pressure Gage

Fits CGA Tank Valve No.	Outlet No.	Typical Usage
A120VBPQ	320	Carbon dioxide, methyl bromide
A120VBPR	350	Hydrogen, carbon monoxide, ethylene
A120VBPS	540	Oxygen
A120VBPT	580	Nitrogen, argon, helium
A120VBPU	590	Air

Note: Can be furnished with DIN/BSP connections on special order

## Safety Check Valves



364VB Check Valve

**Whenever gases or liquids are introduced into a vessel under pressure,** the supply pressure must be greater than the pressure in the vessel to prevent reverse flow back into the supply system. Protection against reverse flow can be obtained by installing a check valve in the supply line. With a check valve in the line, the valve will snap shut if the supply pressure is lower than the pressure in the vessel. This protection is particularly important on stirred reactors

where gas enters through a dip tube. With liquids in the vessel, any back pressure will force liquid back into the gas tank or into the gas supply system.

Parr stocks the poppet check valves for incorporation into the user's supply lines. These valves are typically constructed of T316SS with FKM O-rings with a 10 psi cracking pressure. Alternate O-ring materials and cracking pressures are available upon request.

# Pressure Hoses

**Three different pressure hose assemblies** are available for high pressure gas connections to both stirred and non-stirred vessels. The standard hose is a 6 foot length with a male "A" socket connector on one side and a 1/8" NPT (M) nipple with a 1/4" NPT (M) bushing on the other end. The "A" socket side of the hose attaches to couplings installed on the inlet valve of all stirred reactors and non-stirred vessels, as well as to a side port of the gage block assembly. The choice of either 1/8" NPT or 1/4" NPT on the opposite end of the hose allows for attachment to most gas tank valves, pressure regulators or other gas supply sources.

The A495HC Hose Assembly is made of nylon. It is rated for 2500 psi and is very flexible and easy to use with dry, non-corrosive gases (nitrogen, hydrogen and oxygen). Care must be taken to ensure that the nylon hose does not come in direct contact with any hot surfaces on the vessel or heater. One of these hoses is included with each complete Parr Series 4500, 5100, and 5500 Stirred Pressure Reaction Apparatus.

The A490HC Hose Assembly is a braided, stainless steel hose with a PTFE lining, rated for 2500 psi. It is reasonably flexible and recommended for use with corrosive gases and liquids, and for applications



**A506HC  
Pressure Tube**



**A490HC  
Pressure Hose**



**A495HC Pressure Hose**

requiring additional abrasion resistance, but it is not intended for high temperature liquids or gases.

The A506HC Tube Assembly is a 6-foot length of 1/8" OD stainless steel tubing, rated for 7500 psi. This small diameter tubing is "bendable", but it is not as flexible as the other hoses. It is recommended for corrosive gases, high temperature transfers and other high pressure applications. Special versions of this assembly can be made of other corrosion resistant materials. Larger tubing can be used, but it is rigid rather than flexible.

Special hoses with different lengths or end fittings can be assembled for special orders.

Pressure Hose	
A495HC	Pressure Hose Assembly, 6-ft, reinforced Nylon
A495HC5	Pressure Hose Assembly, 6-ft, reinforced Nylon, with check valve
A495HC7	Pressure Hose Assembly, 10-ft, reinforced Nylon
A495HC8	Pressure Hose Assembly, 10-ft, reinforced Nylon, with check valve
A490HC	Pressure Hose Assembly, 6-ft, PTFE-lined, braided stainless steel
A490HC5	Pressure Hose Assembly, 6-ft, PTFE-lined, braided stainless steel, with check valve
A506HC	Pressure Tube Assembly, 6-ft, 1/8-in OD, T316SS
A506HC2	Pressure Tube Assembly, 6-ft, 1/8-in OD, T316SS, with check valve

Alternate lengths available upon request.

# Thermocouples

**Parr offers a variety of thermocouples** for use in our reactors and pressure vessels. The standard thermocouple is a Type J (iron-constantan) which is compatible with the operating temperature range of these vessels.

The thermocouples are furnished with a sealed 1/8" OD stainless steel sheath and include a standard plug connection at the end of the probe. Our standard thermocouples are manufactured in accordance to ASTM E230.

Alternate thermocouple materials including Alloys C276 and 600 are readily available. Platinum resistance elements (3-wire RTD) are available as special orders as well as multiple point thermocouples.

Most commonly, in small volume vessels the thermocouple probe is installed directly into the vessel with a compression fitting and in larger vessels the probe sits inside a thermowell. The thermowell arrangement offers protection to the thermocouple from physical damage. We also furnish thermowells in vessels manufactured in

materials other than stainless steel so the thermowell will be the alternate alloy and the thermocouple probe can be stainless steel.

Additionally, dual element thermocouples with two separate thermocouples in a single sheath are furnished in smaller volume vessels for use with accessory temperature meters. We also offer spring loaded thermocouples which are designed to be installed through the heater wall to the outside wall of the pressure vessel.

An extension wire is furnished to connect the thermocouple to the control device. The standard length is 5 feet but longer lengths are available if the control is to be mounted away from the reactor.

Type J Thermocouples with 1/8" Diameter		
Part Number	Stem Length, in.	Sheath Material
A472E	7.5	T316 Stainless Steel
A472E2	9.5	T316 Stainless Steel
A472E3	11.5	T316 Stainless Steel
A472E6	15.5	T316 Stainless Steel
A472E5	21.5	T316 Stainless Steel
A472E4	5.5	T316 Stainless Steel
A472E8	2.5	T316 Stainless Steel

Most of the above listed thermocouples are also available as Type K (Chromel-Alumel) or Type T (Copper-Constantan).

# Equipment for Use in Potentially Ignitable Atmospheres

Parr reactors are typically equipped with totally enclosed variable speed motors, electric heaters, and controllers intended for use in non-hazardous environments. These standard units can be used in most laboratories without undue hazard, but there will be situations where the installed equipment must be considered for use in ignitable atmospheres. Parr offers various optional stirrer drives and heating solutions to meet these strict requirements.

## USA and Canadian Codes (HAZLOC – Hazardous Locations)

Designing electrical equipment to be operated in hazardous locations is a complex subject, which is governed by extensive national electrical codes and supplemented by local regulations. These codes require all electrical equipment that is installed in a governed location must be approved for use with the specific gas, vapor, or dust that can be present in the defined location. USA and Canadian electrical codes classify hazardous locations according to the nature and concentration of specific hazardous or flammable materials. These are divided into three classes:

- **Class I** – Flammable liquids, gases or vapors.
- **Class II** – Combustible or electrically conductive dusts.
- **Class III** – Easily ignitable fibers/flyings.

There are two divisions within each of these classes.

- **Division 1** – Where the flammable material exists in the atmosphere under normal operating conditions.
- **Division 2** – Where the hazardous material is confined within a closed system from which it may be released only under abnormal conditions, such as a gas leak in the system.

Class I locations are further subdivided into four groups, A, B, C and D which identify specific explosive gases and vapors. Explosive dusts and fibers in Class II are subdivided into Groups E, F and G. Most hazardous applications for Parr apparatus will occur in atmospheres identified by Class I, Group B for hydrogen and Groups C and D for most other combustible gases and vapors. Class II, Group F covers coal dust. Most other combustible dusts, such as flour and grain, are in Group G. Minimum ignition temperatures and energy levels are established for specific materials in each group.

The European Community has corresponding classifications for “Explosive Atmospheres” referred to as ATEX (ATmospheriques EXplosives). Parr will work with all users to provide equipment compatible with their own local codes.

The components in Parr reactor systems that may be considered hazardous and the steps that can be taken to reduce or eliminate the hazards they represent are described below.

## Motors

Because of sparking from brush contacts, permanent magnet DC electric motors clearly represent the principal ignition source introduced by a stirred reactor. Electric motors approved for Class I (Divisions 1 & 2), Groups C



**Model 4524 Reactor, 2000 mL, Fixed Head Style with Aluminum Block Heater**

and D, and Class II (Divisions 1 & 2), Groups F and G atmospheres are readily available in most sizes and voltages. These totally enclosed motors are suitable for many hazardous applications, and they are sometimes used with hydrogen, though they are not approved for Group B atmospheres. Currently, there are no Division 1 motors available for Group A or B atmospheres. A special air purging system can be used to reduce the classification inside the motor. The motor is pressurized by building up a positive pressure of air, or inert gas, within the motor to prevent explosive gases or vapors from entering the motor housing.



Division 2 requirements are not as stringent. Other motor options are available. Please contact Parr for additional information for Class I, Division 2 requirements.

Parr can provide ATEX rated, IEC framed, AC motors when required. These constant torque motors have lower speed and torque characteristics than the DC motors Parr has used in the last several years.

An alternate method of dealing with the explosion hazard is to use an air driven motor. These are powered by compressed air and offer a convenient and satisfactory drive system for use in flammable atmospheres, including hydrogen. They are available in sizes suitable for most Parr reactors.

### Heaters

The advisable way to heat a Parr reactor in a potentially ignitable atmosphere is to use a hot oil jacket and ensure that the highest temperature of the heat transfer media is below the minimum ignition temperature for the classified area in which it will be installed.

Purging Parr's aluminum block heaters with air, as well as limiting surfaces temperatures below the auto-ignition temperature, can make them suitable for use in classified areas, but it is likely that the air consumption in such heaters will be quite large. Please see our [Heaters section on page 116](#) for additional information.

### Wiring

Parr will provide ordinary location wiring for motors and heaters, which can be used for initial testing, setup, etc. Due to national and local requirements for installation of such equipment, it is the user's responsibility to install mains and motor wiring per code requirements.

Parr will provide wiring for intrinsic safety related sensors, transducers, etc. For application specific information on sensors for use in hazardous locations, please contact Parr Instrument Company.

### Controllers

The most commonly used method for dealing with the ignition hazard introduced by a temperature or process controller is simply to locate the controller outside of the hazardous atmosphere. Another choice is to install the controller in an explosion-proof cabinet or a cabinet that can be purged using the purging system described above.

Air Motor



# Windows



Round, screw-in window



Round, integral window



Custom window



Oblong window

**Windows can be installed** in Parr stirred reactors and pressure vessels for visual observations, light transmission and other purposes. They usually are installed in pairs so that light can be introduced through one window while the other is used for viewing. Our standard material for these windows is fused silica. Sapphire is also available for small diameter windows. Alternative window materials (with coatings, if requested) are available for specific transmission requirements. Windows can be mounted in several different ways.

## Screw-in Circular Windows

The simplest window is a screw-in type with a 1/2-inch diameter viewing area. The windows in these assemblies are sealed in a fitting which screws into the vessel using a standard 1/2 inch NPT male pipe thread. Obviously, the vessel wall must be thick enough to provide full engagement for this thread. O-ring seals restrict the maximum operating temperature to 225 °C or less, depending upon the O-ring material. Alternatively, a Grafoil® gasket seal option is available to increase temperature rating up to 350 °C. Pressure ratings range from 1900 to 5000 psi, depending upon the window material and its thickness. Although these windows are rather small for straight optical viewing, they work well for small video systems and for laser and other analytical beams. A limitation of this design is that there is a dead space approximately 1.25 inches long between the inner face of the window and the inside wall of the vessel.

## Integral Windows

Parr has developed designs for installing windows in the wall of the vessel so that the inside face of the window is very close to the inside wall of the vessel. This eliminates the large dead space associated with screw-in windows. These windows are offered in the two styles described below. The maximum size of the window will depend on the size of the cylinder in which it will be installed.

**Round Windows** with a 1/2-inch diameter viewing area are the standard. Round windows are available in a variety of materials including sapphire for very high pressures (up to 5000 psi). Both O-ring and Grafoil® seals are available in this design. This type of window is generally used for visual, photographic or optical sensor observations.

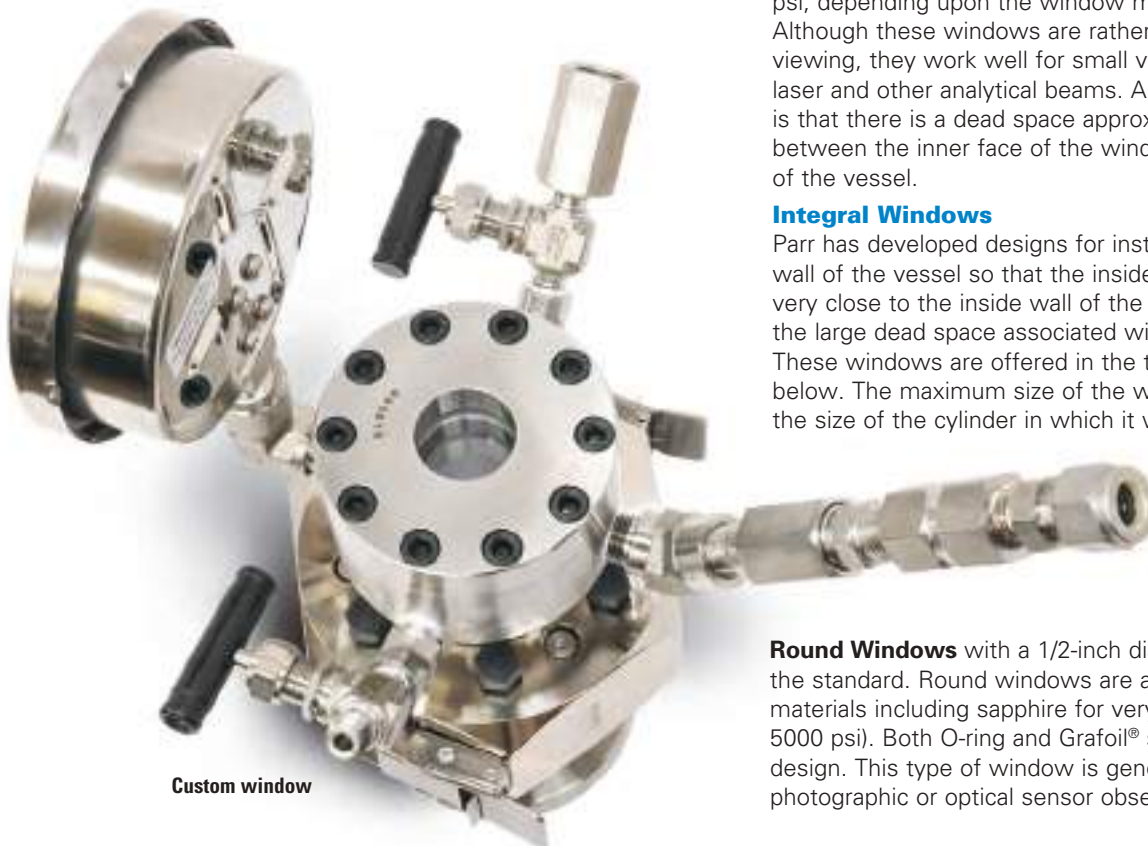

Custom window



Flange-mounted larger window

**Oblong Windows** with a viewing area 3.5-inch long and 0.62-inch wide are the standard size and can be installed on 4590/4790 vessels of 100 mL volume or 4560/4760 vessels of 450 mL volume and larger. Only O-ring seals are available in this design. Both Fused Silica and sapphire windows are available – maximum rating for these windows are limited to 1900 psi at 225 °C with FKM or FFKM seals. These windows are commonly used for visual observations of both the vapor and liquid phases or for observing the liquid level in the vessel. Multiple windows can be stacked or staggered on larger vessels.

The windows described above as standard are maintained in our inventory for readily available replacements. Custom windows in both the round and oblong styles can be furnished in larger sizes upon request. All reactors and pressure vessels equipped with windows require custom designed heaters and supports. Flexible heating mantles, integral cartridge heaters, and attached circulating jackets (600 mL mini and larger) are the most commonly used heaters for window vessels.

#### Externally Welded/Flange Mounted Larger Windows

Large round windows that are either externally welded or flange mounted to the vessel can be installed. These will provide a viewing area of 1-3/4-inch to 7-1/4-inch depending on the size of the window ordered and the size of the vessel. Externally welded windows greatly reduce the maximum working pressure of the vessel to 600 psi or less, although custom configurations rated higher are available.

#### Certification

The windows described above are considered “proprietary fittings” and as such are excluded from the scope of ASME Section VIII Division 1.

Most of the standard windows furnished by Parr can be installed on vessels bearing the CE mark. The windows furnished on these vessels are subjected to various tests on a per lot basis in order to satisfy requirements of 2014/68/EU (Pressure Equipment Directive). Please contact Parr Instrument Company for further information.

## Insulated Electrical Glands

A variety of insulated electrical leads can be installed in most Parr reactors or pressure vessels for electrical connections required inside the vessel. Four commonly used examples are discussed below.

#### Transducer Glands

Transducer glands are available to allow up to 16 individual wires to be sealed and insulated through a single gland. These types of glands are typically used with low voltages and current.

#### Electrode Glands

Applications requiring a single electrical conductor having high current or very high voltage capacities can be handled with an electrode gland. These glands provide a seal for a single conductor or electrode with the ends of the conductor threaded so that internal and external lead wires can easily be attached.

#### Power Leads

Power leads can be provided with either single or multiple flexible wires. Current ratings range from 5 to 20 amperes at up to 600 volts. PTFE or ceramic insulating glands are commonly available. Ceramic glands can be used to the full temperature rating of most Parr vessels. Pressure ratings will vary depending upon the design of the gland, its size, and the type of insulation used.

#### Miscellaneous Sensors

Parr has installed a number of different sensors in its various reactors and pressure vessels, including single point and continuous liquid level sensors, pH electrodes, and dissolved oxygen electrodes. Each of these installations must be carefully developed in consultation with the user, the electrode or probe supplier, and Parr’s Engineering Department. Glass electrodes with O-ring seals will obviously carry rather strict temperature and pressure restrictions. There are also space restrictions which generally dictate that accessories of this type can only be installed in 1000 mL or larger vessels.

## Spare Parts Kits

Each stirred reactor is furnished with a set of spare parts and fittings including a 6-foot gas supply hose, head gaskets, rupture discs, and a set of replacement parts for the stirrer drive.

A reserve supply kit of spare parts can be ordered from Parr Technical Service to provide sufficient parts and tools to handle most normal replacements and emergency repairs during the first year of heavy usage. These kits include replacement gaskets, O-rings, rupture discs, drive belts, and seals. These kits are a convenient package of the small perishable items required for normal maintenance of the reactor.

When ordering any kit for an existing reactor please provide the serial number, specify the preferred gasket/seal material, the burst pressure of the rupture disc, material of the reactor, and the length of the drive belt.

# Temperature Limits

There are a number of factors that determine the maximum temperature rating of a pressure vessel. For most applications it is the gasket material. Vessels with O-ring seals are limited to 225 °C and those with FKM or FFKM are limited to 300 °C. Parr's design for contained PTFE gaskets extends the operating temperature range to 350 °C. Flexible Graphite (FG) material essentially removes the gasket as the limiting factor. Maximum temperature limits for the metals used in these vessels are established by ASME code and other standards. Most metals have maximum temperature limits between 400 and 800 °C. The allowable strength for these metals falls off rapidly as they reach maximum operating temperature. Finally, the difficulties encountered with screw threads and other closure components operating at high temperatures establish a practical temperature limit for externally heated vessels. We have found 600 °C to be a reasonable limit.

## Internally Heated Vessels

**Exposed Heaters.** Another approach that has proven useful in extending the maximum temperature limit is to place the heater inside the pressure vessel. The heater is surrounded by a layer of insulation. This creates a hot zone in the center of the vessel and prevents the walls from exceeding their allowable limit. As this system is very energy efficient, internal heaters can be less powerful than external heaters. Internally heated vessels are equipped with insulated electrical feed-throughs to power the heater. Multiple thermocouples are used to control or monitor the temperatures in the hot zone and on the vessel inner wall.

The reactions or studies carried out in internally heated vessels must be limited to those which will not destroy the exposed internal heaters and insulation. These are normally gas-solid reactions or controlled atmosphere heat treatment studies. The heating elements are normally ceramic. Some users have developed induction style heaters and insulators and have extended their investigations to above 2500 °C.

Although internal heaters can be installed in almost any non-stirred Parr pressure vessel, vessels with larger I.D.s are required in most applications.

**Protected Heaters.** Internally heated vessels have also been manufactured with cartridge type heating elements inserted in specially designed "heater wells". These wells protect the heater from the reactants and expand the applications that can be studied. Cartridge type heaters have a maximum temperature of 760 °C.

# External Valves and Fittings

## Materials of Construction

In the standard configuration, the valves, gage, magnetic drive, and other external parts on Parr reactors are furnished in stainless steel, even when a different material is specified for the head, cylinder, and internal wetted parts. The external stainless components are typically only exposed to the vapor of the reactants and are at much lower temperature than the cylinder and internal fittings. These conditions allow stainless steel external fittings to perform satisfactorily in most cases. If external parts made of a material other than stainless steel are required for safety or other reasons, Parr can accommodate this in most cases. Any request for external parts made of a specific material must be stated clearly when ordering.

## Valves

Most reactor valves are also available in Alloy 400 at a reasonable cost premium. Valves made of Alloy C-276 are also available, but generally only on special designs and at a considerable cost premium. Soft materials such as titanium and zirconium generally make poor performing valves.

## Gages

Pressure gages are available in stainless steel and Alloy 400. Other materials of construction are not available. The standard method for protecting the gage in a corrosive environment is to install a diaphragm gage protector. These have a flexible diaphragm which isolates the gage from the reactants and a sealed hydraulic connection for pressure transfer to the gage. These assemblies are too large to install on all but the largest Parr reactors. The diaphragm assemblies are large and may not be practical on small reactors.

As an alternative, Parr has designed an oil filled piston isolator gage protector to isolate the gage (and transducer, if required) on reactors and pressure vessels where space is limited. These isolators can be furnished in any of the current Parr materials of construction. A piston style isolator can limit the precision the pressure measuring device.

## Pressure Transducers

Pressure transducers are commonly available in stainless steel and Alloy C-276 though other materials may be available. Parr provides a mounting adapter with a water cooling jacket on pressure transducers to protect them from excessive temperatures. These can be augmented with isolators similar to gage protectors when corrosion resistance is required. When a gage and a pressure transducer are installed, a single isolator can protect both.

## Magnetic Drives

Magnetic drives can be furnished in all of the current Parr materials of construction except nickel, which is magnetic.

## Rupture Discs

The standard materials of construction for rupture discs is Alloy 600, gold-faced Alloy 600, and Alloy C-276. Tantalum and other premium materials are available on special order.

Please see the Safety Rupture Disc Assemblies manual 231M for available rupture discs.

# Non-Stirred Reactor Systems **Chapter 8**



## **Inside This Chapter You Will Find:**

[4700 22 & 45 mL](#)

[4740 25 & 75 mL High Pressure](#)

[4750 125 & 200 mL](#)

[4790 25-100 mL](#)

[4790 HPHT 25-100 mL  
High Pressure/High Temperature](#)

[4760 100-600 mL](#)

[4760 HT 300-600 mL  
High Temperature](#)

[4600 1000 & 2000 mL](#)

[4625 600 & 1200 mL  
High Pressure/High Temperature](#)

[4650 250-1000 mL  
High Pressure/High Temperature](#)

[4660 1 & 2 Gallon](#)

[4680 1000 & 1800 mL  
High Pressure/High Temperature](#)

[4670 1 & 1.5 Gallon  
High Pressure/High Temperature](#)

[4675 2.6 & 5 Gallon](#)

[Gage Block Assemblies](#)

[Coned Pressure Fittings](#)

# Non-Stirred Pressure Vessels



Parr offers a broad selection of non-stirred pressure vessels in convenient styles, sizes and pressure ranges for many laboratory uses. Recent additions to this line have included new sizes, new temperature and pressure combinations and new self-sealing closures, all designed to provide convenient vessels for laboratory procedures that must be performed under pressure at elevated temperatures.



## Pressure Vessel Selection Procedure

The steps to be followed in selecting a non-stirred pressure vessel are similar to those used for a stirred reactor. Selection begins with the Guide to Non-Stirred Vessels, from which the user can identify the Model Number for vessels in a range of sizes with temperature and pressure ratings suitable

for the intended application. Detailed specifications and catalog numbers can then be found on the referenced page. After the specifications have been established, the options and accessories required to customize a complete pressure vessel system can be selected.

### Guide to Parr Non-Stirred Vessels

Series Number	Vessel Size	Max. Pressure psi (bar)	Maximum Temperature °C	See Page Number
<a href="#">4700</a>	22 & 45 mL	1700 (115)	300	<a href="#">142</a>
<a href="#">4740</a>	25 & 75 mL	8500 (586)	538	<a href="#">144</a>
<a href="#">4750</a>	125 & 200 mL	3000 (207)*	350	<a href="#">146</a>
<a href="#">4790</a>	25-100 mL	3000 (207)*	350	<a href="#">148</a>
<a href="#">4790HP</a>	25-100 mL	5000 (345)	350	<a href="#">148</a>
<a href="#">4790HP/HT</a>	25-100 mL	5000 (345)	500	<a href="#">148</a>
<a href="#">4760</a>	100-600 mL	3000 (207)*	350	<a href="#">152</a>
<a href="#">4760HT</a>	300-600 mL	2000 (138)	500	<a href="#">152</a>
<a href="#">4600</a>	1000-2000 mL	1900 (131)	350	<a href="#">156</a>
<a href="#">4600HP</a>	970-1900 mL	2900 (200)	350	<a href="#">156</a>
<a href="#">4625</a>	600-1200 mL	5000 (345)	350	<a href="#">160</a>
<a href="#">4650</a>	250-1000 mL	6000 (413)	600	<a href="#">162</a>
<a href="#">4660</a>	1 & 2 gallon	1900 (131)	350	<a href="#">164</a>
<a href="#">4680</a>	1000 & 1800 mL	6000 (413)	600	<a href="#">166</a>
<a href="#">4670</a>	1 & 1.5 gallon	3000 (207)*	500	<a href="#">168</a>
<a href="#">4675</a>	2.6 & 5 gallon	1900 (131)	350	<a href="#">170</a>

\* 200 bar for CE Orders

**Custom options available.** Contact Parr's Customer Service Department.



Model 4600-2L, with 1/4-in plug

### Head Design

Many of the non-stirred vessels offer a basic head with an NPT plug. These should be considered as only a starting point for custom built vessels as they *do not* include a safety relief device. Safety codes, good practice, and common sense dictate that a safety relief device should be installed on all vessels. The NPT plug is provided for the user to install their own safety relief device.

***Users who take delivery of vessels without safety relief devices installed must take responsibility for installing adequate protective devices before the vessel is placed in service.***



Parr Non-Stirred Vessels with Volumes from 22 to 2000 mL.



Available Accessories Include Heaters, Controllers, Valves, Gage Block Assemblies, and Gas Filling Hoses

**Index to Non-Stirred Vessel Design Features, Options and Accessories**

Primary Accessories	Reference Page
<a href="#">Heaters</a>	<a href="#">116</a>
<a href="#">Controllers</a>	<a href="#">99</a>
<a href="#">Gage Block Assemblies</a>	<a href="#">173</a>
<a href="#">Valves and Fittings</a>	<a href="#">132</a>

Options	Reference Page
<a href="#">Gaskets and Seals</a>	<a href="#">18</a>
<a href="#">Materials of Construction</a>	<a href="#">10</a>
<a href="#">Pressure Gages</a>	<a href="#">125</a>
<a href="#">Rupture Disc</a>	<a href="#">124</a>
<a href="#">Certification</a>	<a href="#">8</a>

Accessories*	Reference Page
<a href="#">Liners</a>	<a href="#">129</a>
<a href="#">Pressure Hoses</a>	<a href="#">133</a>
<a href="#">Check Valves</a>	<a href="#">132</a>
<a href="#">Liquid Pipettes</a>	<a href="#">127</a>
<a href="#">Gas Filling Systems</a>	<a href="#">126</a>

\* May require modifications of vessel to install

Series Number:

# 4700

Type:  
**General Purpose**

Mounting Style:  
**Moveable**

Vessel Sizes, mL:  
**22 & 45**

Standard Pressure  
MAWP Rating, psi (bar):  
**1700 (115)**

Maximum Operating  
Temp., °C:  
**300**

## Series 4700 Pressure Vessels, 22 & 45 mL

**These are the smallest of the Parr General Purpose Pressure Vessels.** They have a 1-inch inside diameter and are offered in two different lengths with volumes of 22 and 45 mL.

These vessels have a flat PTFE or flexible graphite gasket that is sealed with a screw cap. Special wrenches and bench sockets are offered for tightening these closures. The screw caps and bodies are made of alloy steel for use at temperatures to 300 °C. The maximum working pressure is 1700 psi (115 bar). The standard material of construction for these small, inexpensive vessels is Type 316 Stainless Steel, but they are also available in all of the current materials of construction Parr provides.

There is room for a single opening on the head of these vessels. This is generally an "A" socket which will accept a 4310 Gage Block Assembly.

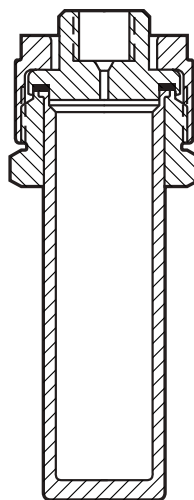

4700-45mL-A Cross Section

These heads can also be furnished with 1/8" NPT, 1/4" NPT, or a rupture disc assembly.

These vessels are normally heated in ovens, baths, or similar general purpose heating devices. Special heaters for these vessels are not available from Parr.



Model 4700-22mL-A Vessel shown with needle valve.

### Series 4700 Pressure Vessel Specifications

Shaded bar indicates specifications that change within series.

Model Number		4700	
Approximate Volume, mL	22	45	
Maximum Pressure (MAWP)	1700 psi (115 bar)		
Maximum Temperature	300 °C		
Vessel Details			
Mounting Style	Moveable Only		
Closure	Screw Cap - Steel		
Head Seal	Flat Gasket		
Head Opening Options	One head opening (1/8" NPT, 1/4" NPT, "A" socket, or rupture disc assembly port) Custom port option (Contact our technical sales department to discuss options)		
Maximum Head Openings	1		
Temperature Measurement	N/A		
Stand and Heater Type	N/A		
Weight and Dimensions			
Cylinder I.D. x Depth, inches	1.0 x 1.6	1.0 x 3.8	
Vessel Assembly Weight, pounds*	0.8	1.10	
Cylinder Weight, pounds	0.2	0.5	

\*Vessel weight is based on a moveable head vessel with a plugged "A" socket. Vessel weight will vary based on head configuration choice and fitting options.

Other options available. See Ordering Guide, visit [www.parrinst.com](http://www.parrinst.com), or call for more information.



## Series 4700 Ordering Guide

An example order number for a vessel this series is:

**4700-45mL-T-SS-A-21AC4-A22AC3**

A composite identification number to be used when ordering a 4700 Series Pressure Vessel can be developed by combining individual symbols from the separate sections below. For more information on how to use this ordering guide, [please see page 27](#).



Model 4700-45mL-A Vessel, with 4310 Gage Block Assembly.

### A Vessel Volume

-22mL	22 mL, 1" ID
-45mL	45 mL, 1" ID

### B Gasket / Maximum Temperature

-T	PTFE Gasket, 300 °C
-FG	Flexible Graphite Flat Gasket, 300 °C

### C Materials of Construction

-SS	T316 Stainless Steel
-C20	Alloy 20
-MO	Alloy 400
-IN600	Alloy 600
-IN625	Alloy 625
-HB	Alloy B-2 / B-3
-HC	Alloy C-276
-NI	Nickel 200
-TI2	Titanium Grade 2
-TI4	Titanium Grade 4
-ZR702	Zirconium Grade 702
-ZR705	Zirconium Grade 705

See [page 10](#) or [24](#) for complete list of available alloys.

### D Head Configuration

-RD	Rupture disc port with rupture disc assembly & disc
-1/8	One head opening, 1/8" NPT port, plugged
-1/4	One head opening, 1/4" NPT port, plugged
-A	One head opening, "A" socket
-NS	Non-standard, custom head opening

### E Optional Fittings & Custom Options (Check all needed)

-V	Needle Valve
-4310A	Gage Block Assembly (for head with "A" socket opening)

### F Required Accessories

Part No.	Description
-21AC4	Wrench
-A22AC3	Bench Socket

### G Certifications

-ASME	ASME Documentation
-CE	CE Documentation
-P	Parr Certification

Please note that all options and combinations are not compatible with all models.

Series Number:

**4740**Type:  
**High Pressure /  
High Temperature**Vessel Mounting:  
**Moveable**Vessel Sizes, mL:  
**25 & 75**Maximum Pressure  
MAWP Rating, psi (bar):  
**8500 (586)**Maximum Operating  
Temp., °C:  
**538**

## Series 4740 HP/HT Pressure Vessels, 25 & 75 mL

**These high pressure/high temperature pressure vessels have a 1-inch.** They have a 1-inch inside diameter and offer volumes of 25 or 75 mL. These vessels are closed with an alloy steel screw cap which includes six compression bolts to develop the sealing force on a flat, flexible graphite gasket. Interchangeable PTFE gaskets are also available for users who need the high pressure capabilities provided by these vessels, but who do not need to operate above 350 °C. Maximum pressure drops quickly at temperatures above 350 °C to a rating of 1850 psi (125 bar) at 538 °C. These vessels are available in all of the standard materials currently offered by Parr, although some of these materials will limit the maximum pressures and temperatures available.

The head of these vessels can only accommodate one opening. It is designed to accept the 4310A Gage Block Assembly which can be furnished with or without a thermocouple. Parr offers the 4921 Bench Top Ceramic Fiber heater for use with the 75 mL, 4740 Vessel only. The smaller 25 mL Vessels are generally heated in an oven, bath, furnace or similar general purpose heater (not available from Parr)

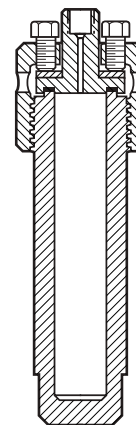
**4740-75 mL Cross Section**

Series 4740 Pressure Vessel Specifications		
Shaded bar indicates specifications that change within series.		
Approximate Volume, mL	25	75
<b>Maximum Pressure</b>		
Head & Cylinder of T316SS With Standard Screw Cap	8500 psi (586 bar) @ 350 °C 4100 psi (282 bar) @ 500 °C 1850 psi (127 bar) @ 538 °C	
Head & Cylinder of T316SS With Alloy C-276 Screw Cap	8500 psi (586 bar) @ 350 °C 8000 psi (551 bar) @ 500 °C 7900 psi (544 bar) @ 538 °C	
<b>Maximum Temperature</b>		
With PTFE Flat Gasket	350 °C	
With Flexible Graphite Flat Gasket	500-538 °C	
<b>Vessel Details</b>		
Mounting Style	Moveable	
Closure	Screw Cap (6 Compression Bolts)	
Head Seal	Flat Gasket	
Head Opening Options	One head opening ("A" socket, or rupture disc assembly port) Custom port option (Contact our technical sales department to discuss options)	
Maximum Head Opening	1	
Temperature Measurement (Optional)	Thermocouple (in cylinder bottom or in optional gage block assembly)	
<b>Stand and Heater (optional)</b>		
Stand type	N/A	Bench Top Stand with Heater
Heater Style		Ceramic Fiber
Heater Power, Watts		700
Maximum Load, amps, 115V / 230V		6 / 3
<b>Weight and Dimensions</b>		
Cylinder I.D. x Depth, inches	1.0 x 1.7	1.0 x 5.6
Vessel Assembly Weight, pounds*	4	6
Cylinder Weight, pounds	1.4	3.2
*Vessel weight is based on a moveable head vessel with a plugged "A" socket. Vessel weight will vary based on head configuration choice and fitting options.		
Other options available. See Ordering Guide, visit <a href="http://www.parrinst.com">www.parrinst.com</a> , or call for more information.		

# Series 4740 Ordering Guide

An example order number for a vessel in this series is:

**4740-75mL-FG-SS-A**

A composite identification number to be used when ordering a 4740 Series Pressure Vessel System can be developed by combining individual symbols from the separate sections below. For more information on how to use this ordering guide, [please see page 27](#).



Model 4740-75mL-A Vessel, with 4310 Gage Block Assembly.



Model 4740-75mL Vessel, with bench top stand and Ceramic Fiber Heater (-BTS).

A Vessel Volume	
-25mL	25 mL, 1" ID
-75mL	75 mL, 1" ID

B Gasket / Maximum Temperature	
-T	PTFE Gasket, 350 °C
-FG	Flexible Graphite Flat Gasket, 500-538 °C

C Materials of Construction	
-SS	T316 Stainless Steel
-C20	Alloy 20
-MO	Alloy 400
-IN600	Alloy 600
-IN625	Alloy 625
-HB	Alloy B-2 / B-3
-HC	Alloy C-276
-NI	Nickel 200*
-TI2	Titanium Grade 2*
-TI4	Titanium Grade 4*
-ZR702	Zirconium Grade 702*
-ZR705	Zirconium Grade 705*

\* Maximum temperature and/or pressure limited  
See [page 10](#) or [page 24](#) for complete list of available alloys.

D Head Configuration	
-RD	Rupture disc port with rupture disc assembly & disc
-A	One head opening, "A" socket
-NS	Non-standard, custom head opening

E Optional Fittings & Custom Options (Check all needed)	
-HCSC	Alloy C-276 Screw Cap for HPHT
-TC	Thermocouple (in cylinder bottom)
-4310A	Gage block assembly (for head with "A" socket opening)
-4310ATC	Gage block assembly with thermocouple (for head with "A" socket opening)

F Pressure Gage Option	
-No Symbol	None
-10,000	10,000 psi / 690 bar
-7500	7500 psi / 517 bar
-5000	5000 psi / 345 bar
-3000	3000 psi / 207 bar
-2000	2000 psi / 138 bar

Please note that all options and combinations are not compatible with all models.

G Stand with Heater Options	
-No Symbol	None
-BTS	Ceramic Fiber Heater w/Stand, 700W

H Controller	
-No Symbol	None
-4838	PID Control, Ramp & Soak Programming, and Data logging with Software (RS-485 to USB cable not included). For use with one additional display module.
-4848	PID Control, Ramp & Soak Programming, and Data logging with Software. (RS-485 to USB cable not included). For use with up to three additional display modules.

See [Chapter 6](#) for complete list of Controller options.

I Controller Options (Check all needed)	
-PDM	Pressure Display Module
-HTM	High Temperature Cut Off Module
-ETLM	External Temperature Limit Module
-SVM	Solenoid Valve Module (for cooling control)
-A1925E4	RS-485 to USB Cable for 4838/4848 Controller (required for data logging)
-A1925E6	RS-485 to USB Converter, isolated, 30-ft
-A2208E	RS-485 Daisy Chain for Multiple Controllers (Must be used with A1925E6)
-A3504HC	SpecView Software Package for 4838/4848 Controller

J Electrical Supply for Heater and/or Controller	
-No Symbol	None
-115	115V Power
-230	230V Power

K Certifications	
-ASME	ASME Documentation
-CE	CE Documentation
-P	Parr Certification

Please note that all options and combinations are not compatible with all models.

Series Number:

**4750**Type:  
**General Purpose**Mounting Style:  
**Moveable**Vessel Sizes, mL:  
**125 & 200**Standard Pressure  
MAWP Rating, psi (bar):  
**3000 (200)**Maximum Operating  
Temp., °C:  
**350**

## Series 4750 General Purpose Pressure Vessels, 125 & 200 mL

**General Purpose 4750 Series Vessels** are available in volumes of 125 and 200 mL, with temperatures up to 350 °C and maximum pressure of 3000 psi (200 bar). They come standard with a Split Ring closure with 6 compression bolts, and a choice of three different head styles: 1/8" NPT w/plug, an "A" Socket, or an "A" Socket with Thermocouple. The maximum amount of openings for this head style is two and would be dependent on the size of the ports and the type of fittings required. For the 4750 Series General Purpose Vessels, Parr offers the 4921 Ceramic Fiber Heater.

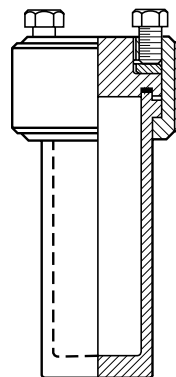
**4750 Cross Section****Model 4750-200mL-A  
Vessel, with 4310 Gage  
Block Assembly.**

### Series 4750 Pressure Vessel Specifications

Shaded bar indicates specifications that change within series.

Model Number	4750	
Approximate Volume, mL	125	200
Maximum Pressure (MAWP)	3000 psi (207 bar, 200 bar for CE orders)	
Maximum Temperature	350 °C	
<b>Vessel Style</b>		
Head Style	Moveable	
Closure	Split-Ring (6 Compression Bolts)	
Head Seal	Flat Gasket - PTFE	
Head Opening Options	One head opening (1/8" NPT, 1/4" NPT, "A" socket, or rupture disc assembly port) Two head openings ("A" socket and 1/8" NPT or two 1/8" NPT) Custom port option (Contact our technical sales department to discuss options)	
Maximum Head Openings	2	
Temperature Measurement (optional)	Fixed Thermocouple (Thermowell for special alloys)	
<b>Stand and Heater (optional)</b>		
Stand Type	Bench Top Stand with Heater	
Heater Style	Ceramic Fiber	
Head Style	700	
Head Style	6 / 3	
<b>Weight and Dimensions</b>		
Cylinder I.D. x Depth, inches	1.5 x 4.4	1.5 x 6.9
Vessel Assembly Weight, pounds*	4.4	5
Cylinder Weight, pounds	1.7	2.4
*Vessel weight is based on a moveable head vessel with a "A" socket and 1/8" NPT port. Vessel weight will vary based on head configuration choice and fitting options.		
Other options available. See Ordering Guide, visit <a href="http://www.parrinst.com">www.parrinst.com</a> , or call for more information.		

# Series 4750 Ordering Guide



Model 4750-125mL-A Vessel, with 4310 Gage Block Assembly.



Available stand assembly with heater

An example order number for a vessel in this series is:  
**4750-125mL-T-SS-A-21AC4-A22AC3**

A composite identification number to be used when ordering a 4750 Series Pressure Vessel System can be developed by combining individual symbols from the separate sections below. For more information on how to use this ordering guide, [please see page 27](#).

A Vessel Volume	
-125mL	125 mL, 1" ID
-200mL	200 mL, 1" ID

B Gasket / Maximum Temperature	
-T	PTFE Gasket, 350 °C
-FG	Flexible Graphite Flat Gasket, 500-538 °C

C Materials of Construction	
-SS	T316 Stainless Steel
-C20	Alloy 20
-MO	Alloy 400
-IN600	Alloy 600
-IN625	Alloy 625
-HB	Alloy B-2 / B-3
-HC	Alloy C-276
-NI	Nickel 200
-TI2	Titanium Grade 2
-TI4	Titanium Grade 4
-ZR702	Zirconium Grade 702
-ZR705	Zirconium Grade 705

See [page 10](#) or [24](#) for complete list of available alloys.

D Head Configuration	
-RD	Rupture disc port with rupture disc assembly & disc
-1/8	One head opening, 1/8" NPT port, plugged
-1/4	One head opening, 1/4" NPT port, plugged
-A	One head opening, "A" socket
-A & 1/8	Two head openings, "A" socket & 1/8" NPT w/ thermocouple
-(2)1/8	Two head openings, (2) 1/8" NPTF(s) w/ plug and w/ thermocouple
-NS	Non-standard, custom head opening

E Optional Fittings & Custom Options (Check all needed)	
-4310A	Gage block assembly (for head with "A" socket opening)
-TC	Thermocouple (requires 1/8" NPT opening)

F Pressure Gage Option (Gage Block Assembly Required)	
-No Symbol	None
-3000	3000 psi / 207 bar
-2000	2000 psi / 138 bar
-1000	1000 psi / 69 bar
-600	600 psi / 40 bar
-200	200 psi / 14 bar
-100	100 psi / 7 bar

G Stand with Heater Options	
-No Symbol	None
-BTS	Bench Top Stand w/ Heater

H Controller	
-No Symbol	None
-4838	PID Control, Ramp & Soak Programming, and Data logging with Software (RS-485 to USB cable not included). For use with one additional display module.
-4848	PID Control, Ramp & Soak Programming, and Data logging with Software. (RS-485 to USB cable not included). For use with up to three additional display modules.

See [Chapter 6](#) for complete list of Controller options.

I Controller Options (Check all needed)	
-PDM	Pressure Display Module
-HTM	High Temperature Cut Off Module
-ETLM	External Temperature Limit Module
-SVM	Solenoid Valve Module (for cooling control)
-A1925E4	RS-485 to USB Cable for 4838/4848 Controller (required for data logging)
-A1925E6	RS-485 to USB Converter, isolated, 30-ft
-A2208E	RS-485 Daisy Chain for Multiple Controllers (Must be used with A1925E6)
-A3504HC	SpecView Software Package for 4838/4848 Controller

J Electrical Supply for Heater and/or Controller	
-No Symbol	None
-115	115V Power
-230	230V Power

K Certifications	
-ASME	ASME Documentation
-CE	CE Documentation
-P	Parr Certification

Please note that all options and combinations are not compatible with all models.

Series Number:

# 4790

Type:  
**Micro**

Stand:  
**Bench Top**

Mounting Style:  
**Moveable or  
Fixed Head**

Sizes, mL:  
**25, 50, 100**

Standard Pressure  
MAWP Rating, psi (bar):  
**3000 (200)**

High Pressure (HP)  
MAWP Rating, psi (bar):  
**5000 (345)**

Standard Maximum  
Operating Temp., °C:  
**225 w/ FKM O-ring**  
**300 w/ FFKM O-ring**  
**350 w/ PTFE Flat Gasket**

High Temperature (HT) /  
High Pressure (HP)  
Maximum Operating  
Temperature, °C:  
**500 w/ FG Flat Gasket  
(Fixed Head Only)**

## Series 4790 Pressure Vessels, 25-100 mL

**These small pressure vessels** are a good choice for chemists working with very expensive materials or materials only available in small amounts. They will also appeal to users who wish to minimize the risks associated with hazardous materials or reactions by restricting the reactants or products to a minimum. Use of the Series 4790 Vessels also helps minimize the quantities of waste products which may require special disposal procedures. The 4790 Vessels are now available in high pressure (5000 psi) or high pressure/high temperature (500 °C) versions.

These micro vessels have been designed to provide as many of the features of the larger vessels as possible in the limited space available. The standard head fittings include a gage, rupture disc, thermocouple, and valves. Optional cooling is available with aluminum block heaters with cooling capability, welded jackets, or cold fingers.

The vessels are offered in both fixed head and moveable head vessel styles with choices of a self sealing O-ring for temperatures up to 225 °C or with FFKM O-ring for temperatures to 300 °C or with a flat PTFE flat gasket for temperatures to 350 °C, or with an FG Flexible Graphite gasket for temperatures to 500 °C with the HP/HT option (for fixed head versions only). A split ring closure is standard.

All three volumes use the same bench top ceramic fiber heater.

These micro vessels can be easily converted from one size to another by simply substituting a larger or smaller cylinder and the corresponding internal fittings.

The support system can also be readily adapted to accept any of the vessels from the 4790 Series Vessels. The opportunity to modify these small reactors is restricted because of the limited head space available.

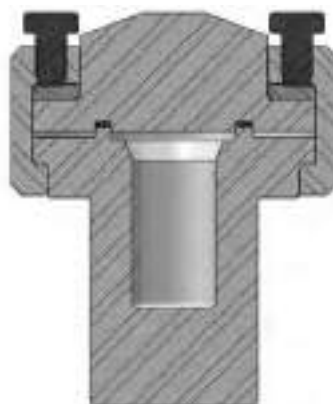

4790-25mL Cross Section  
with Flat Gasket Seal



4790-25mL Cross Section  
with O-ring Seal



4790-100mL-VGR-DVD Moveable Head Vessel with PTFE Flat Gasket

# 4790

Series 4790 Pressure Vessel Specifications			
Shaded bar indicates specifications that change within series.			
Model Number	4790		
Approximate Volume, mL	25	50	100
<b>Maximum Pressure (MAWP)</b>			
Standard Rating	3000 psi (207 bar, 200 bar for CE orders)		
High Pressure (HP)	5000 psi (345 bar)		
High Pressure/High Temperature (HP/HT)	5000 psi (345 bar)		
<b>Maximum Temperature</b>			
with FKM O-ring	225 °C		
with FFKM O-ring	300 °C		
with PTFE Flat Gasket	350 °C		
with Flexible Graphite Flat Gasket (HP/HT only)	500 °C		
<b>Vessel Details</b>			
Mounting Style	Moveable or Fixed Head (HP/HT option requires Fixed Head)		
Closure	Split-Ring (6 Compression Bolts for Flat Gasket, no Compression Bolts for O-ring) or Screw Cap (O-ring seal only)		
Head Opening Options	One head opening (1/8" NPT*, 1/4" NPT*, "A" socket, or rupture disc assembly port) Ports for valve, gage, rupture disc, and thermocouple (VGR**) Custom port option (Contact our technical sales department to discuss options)		
Maximum Head Openings	5 (Dependent on opening size, and required fittings)		
Valve Connections	1/8" NPT Male (standard rating), 1/4" NPT Male (HP), 1/4" NPT Female (HP/HT)		
Pressure Gage, Size	3.5 inches		
Range, Standard Temperature	0-3000 psi (207 bar)		
Range, HP & HP/HT	0-5000 psi (345 bar)		
Temperature Measurement	Fixed Thermocouple (Thermowell for special alloys)		
Cooling (optional)	Cold Finger		
* NPT ports are not available for vessels with a High Temperature (HT) rating. ** 4790HPHT requires VGR.			
<b>Stand and Heater (optional)</b>			
Stand Type	Heater Only (standard rated and HP vessels only) and Bench Top Stand with Heater (required for HT vessels)		
Heater Style (Standard rating & HP)	Ceramic Fiber Heater		
Heater Power, Watts	700	700	350
Maximum Load, amps, 115V / 230V	6 / 3	6 / 3	3 / 2
Heater Style (HP/HT)	Ceramic Fiber Heater		
Heater Power, Watts	700		
Maximum Load, amps, 115V / 230V	6 / 3		
<b>Weight and Dimensions</b>			
Cylinder I.D. x Depth, inches	1.0 x 2.0	1.3 x 2.3	1.3 x 4.6
Vessel Assembly w/ Moveable Head, Weight, pounds**	16	15	16
Vessel Assembly w/ Fixed Head, Weight, pounds**	17	17	18
Cylinder Weight, pounds	3.5	3.1	4.2
** Vessel Assembly weight varies based on head configuration choice and fitting options. Weights shown are based on vessels with valve, gage, rupture disc, thermocouple, and double valve assembly.			
Other options available. See Ordering Guide, visit <a href="http://www.parrinst.com">www.parrinst.com</a> , or call for more information.			

Series Number:

# 4790

## Series 4790 Pressure Vessel Systems

### Index to Options

Option	Page
Certification	8
Materials of Construction	10
Magnetic Drive	14
Gaskets & Seals	18
Stirrer Motor	118
Rupture Disc	124
Pressure Gage	125
Cooling Coil	129
Bottom Drain Valve	131
4848 Reactor Controller	102
4871 Process Controller	109
A2110E Motor Controller	114

Custom Option	Page
Stirrers	120
Heaters	116
External Valves & Fittings	138
Solids Charging Ports	128
Condensers	123
Electrical Glands	137
Catalyst Addition Device	128
Catalyst Baskets	122
Relief Valves	125
Windows	136
Gear Drives	119
Explosion Proof Options	134
Liquid Sampling	130

Accessories	Page
Liners	129
Spare Parts Kits	137
Pressure Hoses	133
Check Valves	125
Liquid Pipettes	127
Gas Burettes	126

Model 4790-25mL Vessel  
w/ Double Valve Assembly



4790-100mL-HP/HT Fixed Head Vessel



# Series 4790 Ordering Guide

An example order number for a vessel in this series is: **4790-25mL-T-SS-3000**

A composite identification number to be used when ordering a 4790 Series Pressure Vessel System can be developed by combining individual symbols from the separate sections below. For more information on how to use this ordering guide, [please see page 27](#).

A Vessel Volume	
-No Symbol	3000 psi / 207 bar, 200 bar for CE orders @ 350 °C
-HP	5000 psi / 345 bar @ 350 °C
-HPHT	5000 psi / 345 bar @ 350 °C

B Vessel Volume	
-25mL	25 mL, 1" ID
-50mL	50 mL, 1.3" ID
-100mL	100 mL, 1.3" ID

C Head Mounting Style	
-No Symbol	Moveable Head (Standard configuration)
-FH	Fixed Head (Required for HP/HT rating)

D Gasket / Maximum Temperature	
-T	PTFE Flat Gasket, 350 °C
-OV	FKM O-ring, 225 °C
-OK	FFKM O-ring, 300 °C
-FG	Flexible Graphite Flat Gasket, 500 °C (HPHT option only)

E Materials of Construction	
-SS	T316 Stainless Steel
-C20	Alloy 20*
-M0	Alloy 400*
-IN600	Alloy 600
-IN625	Alloy 625
-HB	Alloy B-2 / B-3*
-HC	Alloy C-276
-NI	Nickel 200
-Ti2	Titanium Grade 2*
-Ti4	Titanium Grade 4*
-ZR702	Zirconium Grade 702*
-ZR705	Zirconium Grade 705*

\* High temperature option not available.  
See page 10 or 24 for complete list of available alloys.

F Head Configuration	
-RD	Rupture disc port with rupture disc assembly & disc
-1/8	One head opening, 1/8" NPT port, plugged
-1/4	One head opening, 1/4" NPT port, plugged
-A	One head opening, "A" socket
-VGR	Valve on gage adapter, pressure gage, rupture disc assembly, & thermocouple (includes thermowell for special alloys)
-NS	Non-standard, custom head opening

G Optional Fittings & Custom Options (Check all needed)	
-VD	Single Valve on head with dip tube (VGR Required)
-DVD	Double Valve Assembly on head with dip tube (VGR Required)
-CF	Cold Finger
-4310A	Gage Block Assembly (for head with "A" socket opening)
-CAD	Internal Catalyst Addition Device
-XCAD	External Catalyst Addition Device
-SCP	Solids Charging Port (Ball Valve)
-RC	Reflux Condenser
-RTC	Reflux/Take-Off Condenser
-WJ	Welded Jacket

H Pressure Gage	
-No Symbol	Single Valve on head with dip tube (VGR Required)
-5000	5000 psi / 345 bar
-3000	3000 psi / 207 bar
-2000	2000 psi / 138 bar
-1000	1000 psi / 69 bar
-600	600 psi / 40 bar
-200	200 psi / 14 bar
-100	100 psi / 7 bar

I Stand and Heater Options	
-No Symbol	None
-NS	Heater only, no stand (Temperatures up to 350 °C)
-BTS	Bench Top Stand with Heater

See Section "G" for Welded Jacket option

J Controller	
-4838	PID Control, Ramp & Soak Programming, and Data logging with Software (RS-485 to USB cable not included). For use with one additional display module.
-4848	PID Control, Ramp & Soak Programming, and Data logging with Software. (RS-485 to USB cable not included). For use with up to three additional display modules.

See Chapter 6 for complete list of Controller options.

K Controller Options (Check all needed)	
-PDM	Pressure Display Module
-HTM	High Temperature Cut Off Module
-ETLM	External Temperature Limit Module
-SVM	Solenoid Valve Module (for cooling control)
-A1925E4	RS-485 to USB Cable for 4838/4848 Controller (required for data logging)
-A1925E6	RS-485 to USB Converter, isolated, 30-ft
-A2208E	RS-485 Daisy Chain for Multiple Controllers (Must be used with A1925E6)
-A3504HC	SpecView Software Package for 4838/4848 Controller

L Electrical Supply for Heater and/or Controller	
-No Symbol	None
-115	115V Power
-230	230V Power

M Certifications	
-No Symbol	No Certification
-ASME	ASME Documentation
-CE	CE Documentation
-P	Parr Certification

Please note that all options and combinations are not compatible with all models.

Series Number:

# 4760

Type:  
**Mini**

Stand:  
**Bench Top**

Mounting Style:  
**Moveable or  
Fixed Head**

Sizes, mL:  
**100-600**

Standard Pressure  
MAWP Rating, psi (bar):  
**3000 (200)**

High Pressure (HP)  
MAWP Rating, psi (bar):  
**2000 (138)**

Standard Maximum  
Operating Temp., °C:  
**225 w/ FKM O-ring**  
**300 w/ FFKM O-ring**  
**350 w/ PTFE Flat Gasket**

High Temperature (HT) /  
Maximum Operating  
Temperature, °C:  
**500 w/ FG Flat Gasket**

## Series 4760 Pressure Vessels, 100-600 mL

**These are the most popular of our small general purpose vessels.** Parr offers a range of sizes large enough to work with significant sample sizes, yet small enough to be handled with ease by all operators.

They are made in both fixed head and moveable vessel styles and are available with an FKM O-ring seal for operating temperatures to 225 °C, and FFKM O-ring for temperatures to 300 °C, or with a flat, PTFE gasket for operating temperatures up to 350 °C maximum.

Choosing the high temperature option (HT) boosts the maximum temperature to 500 °C, but reduces the MAWP to 2000 psi (138 bar). Standard temperature vessels can be converted to high temperature vessels (500 °C max temperature and 2000 psi MAWP) by changing the head assembly (contains cone connections, high temperature valves, and Grafoil® gasket) replacing the heater with a ceramic fiber heater and replacing the split ring. Contact Parr for details.

Although internal and external space is limited on these small vessels, custom ports and fittings are available. All vessels in this series can also be easily

converted from one size to another by simply substituting a longer or shorter cylinder with the corresponding internal fittings and heater.

Clamp-on or mantle heaters are available for the Series 4760 moveable vessels. Stands with heaters are offered for the fixed head vessels.

The heaters furnished for non-stirred vessels are the same as those furnished for the stirred versions of the same size vessels. A full description of the different types of heaters is found in our Heater Options section. Automatic temperature controllers are available for most Parr non-stirred vessels.

Custom heaters are also available for these vessels when it is necessary to meet explosion proof requirements, to accommodate installed windows or fittings, or to convert to a welded jacket for steam or oil heating.

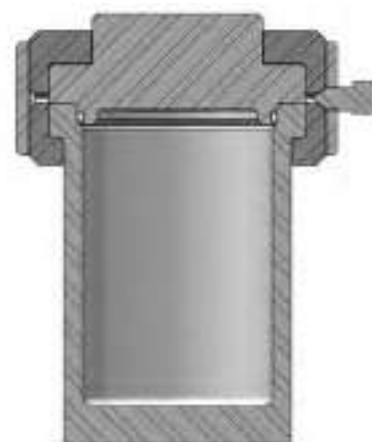

**4760Q Cross Section  
with O-ring Seal**

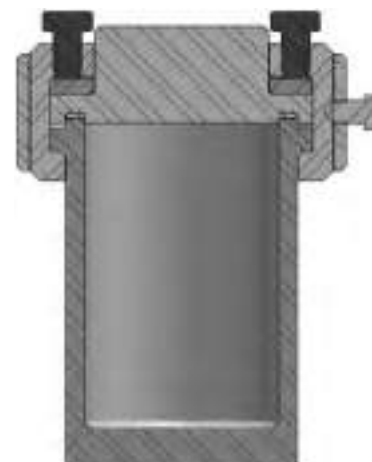

**4760 Cross Section  
with Flat Gasket Seal**

**4760-160mL-VGR-DVD Vessel, BTS Support Stand w/ Heater,  
and 4838 Controller.**



**4760-300mL with plug and rupture disc  
assembly installed.**

# 4760

Series 4760 Pressure Vessel Specifications					
Shaded bar indicates specifications that change within series.					
Model Number	4760				
Approximate Volume, mL	100	160	300	450	600
Maximum Pressure (MAWP)	3000 psi (207 bar, 200 bar for CE orders)				
Maximum Pressure for HT (MAWP)	N/A		2000 psi (138 bar)		
Maximum Temperature					
with FKM O-ring	225 °C				
with FFKM O-ring	300 °C				
with PTFE Flat Gasket	350 °C				
with Grafoil Gasket (HT)	N/A		500 °C		
Vessel Details					
Mounting Style	Moveable or Fixed Head				
Closure	Split-Ring (6 Compression Bolts for Flat Gasket, no Compression Bolts for O-ring)				
Head Opening Mounts	One head opening (1/8" NPT*, 1/4" NPT*, "A" socket, or rupture disc assembly port) Ports for valve, gage, rupture disc, and thermocouple (VGR) Custom port option (Contact our technical sales department to discuss options)				
Maximum Head Openings	7 (Dependent on opening size, and required fittings)				
Valve Connections	1/8" NPT Male, 1/8" NPT Female for HT				
Pressure Gage, Size	3.5 inches				
Range, Standard Temperature	0-3000 psi (207 bar)				
Range, High Temperature	N/A		0 - 2000 psi (138 bar)		
Temperature Measurement	Fixed Thermocouple (Thermowell for special alloys)				
Cooling Coil (optional)	N/A		Single Loop		
Bottom Drain Valve (BDV) (optional)	1/4" NPT (Not available on HT Models)				
* NPT ports are not available for vessels with a High Temperature (HT) rating.					
Stand and Heater (optional)					
Cooling Coil (optional)	Heater Only (standard rated vessels only) and Bench Top Stand with Heater (standard rated vessels and high temperature rated vessels)				
Heater Style (Standard Temperature)	Clamp-on Band		Rigid Mantle		
Heater Power, Watts	525		510	590	780
Maximum Load, amps (115V / 230V), Nominal	5 / 3		5 / 3	5 / 3	7 / 4
Heater Style (High Temperature)	N/A		Ceramic Fiber		
Heater Power, Watts			800	800	1100
Maximum Load, amps (115V / 230V), Nominal			7 / 4	7 / 4	10 / 5
Weight & Dimensions					
Cylinder I.D. x Depth, inches	2.0 x 2.0	2.5 x 2.0	2.5 x 4.0	2.5 x 6.0	2.5 x 8.0
Vessel Assembly w/ Moveable Head Weight, pounds**	14	13	14	15	17
Vessel Assembly w/ Moveable Head Weight, pounds**	15	14	15	17	18
Cylinder Weight, pounds	3.3	2.4	3.7	4.9	6.2
** Vessel Assembly weight varies based on head configuration choice and fitting options. Weights shown are based on vessels with valve, gage, rupture disc, thermocouple, and double valve assembly.					
Other options available. See Ordering Guide, visit <a href="http://www.parrinst.com">www.parrinst.com</a> , or call for more information.					

## Series 4760 Pressure Vessel Systems

## Index to Options

Option	Page
Certification	8
Materials of Construction	10
Magnetic Drive	14
Gaskets & Seals	18
Stirrer Motor	118
Rupture Disc	124
Pressure Gage	125
Cooling Coil	129
Bottom Drain Valve	131
4848 Reactor Controller	102
4871 Process Controller	109
A2110E Motor Controller	114

Custom Option	Page
Stirrers	120
Heaters	116
External Valves & Fittings	138
Solids Charging Ports	128
Condensers	123
Electrical Glands	137
Catalyst Addition Device	128
Catalyst Baskets	122
Relief Valves	125
Windows	136
Gear Drives	119
Explosion Proof Options	134
Liquid Sampling	130

Accessories	Page
Liners	129
Spare Parts Kits	137
Pressure Hoses	133
Check Valves	125
Liquid Pipettes	127
Gas Burettes	126



Model 4760-300mL, VGR-VD with PTFE Flat Gasket and optional second valve.



Model 4760-300mL-A Vessel with Adapter and Needle Valve.

Model 4760-600mL, with VGR, O-ring seal, and single inlet valve.



4760-300mL, Fixed Head, Quick-release Split Ring, and a 4838 Temperature Controller.

# Series 4760 Ordering Guide

An example order number for a vessel in this series is: **4760-100mL-T-SS-VGR-3000**

A composite identification number to be used when ordering a 4760 Series Pressure Vessel System can be developed by combining individual symbols from the separate sections below. For more information on how to use this ordering guide, [please see page 27](#).

A Vessel Rating	
-No Symbol	3000 psi, 200 bar @ 350 °C
-HT	2000 psi, 138 bar @ 500 °C (300, 450, or 600 mL only)
<i>High Pressure sizes are 970 mL &amp; 1900 mL</i>	
B Vessel Volume	
-100mL	100 mL, 2.0" ID
-160 mL	160 mL, 2.5" ID
-300 mL	300 mL, 2.5" ID
-450 mL	450 mL, 2.5" ID
-600 mL	600 mL, 2.5" ID
C Head Mounting Style	
-No Symbol	Moveable Head (Standard configuration)
-FH	Fixed Head
D Gasket / Maximum Temperature	
-T	PTFE Flat Gasket, 350 °C
-OV	FKM O-ring, 225 °C
-OK	FFKM O-ring, 300 °C
-FG	Flexible Graphite, Flat Gasket, 500 °C (HT option only)
E Vessel Material of Construction	
-SS	T316 Stainless Steel
-C20	Alloy 20*
-M0	Alloy 400*
-IN600	Alloy 600
-IN625	Alloy 625
-HB	Alloy B-2 / B-3*
-HC	Alloy C-276
-NI	Nickel 200
-TI2	Titanium Grade 2*
-TI4	Titanium Grade 4*
-ZR702	Zirconium Grade 702*
-ZR705	Zirconium Grade 705*
<i>*High temperature option not available.</i>	
<i>See page 10 or 24 for complete list of available alloys.</i>	
F Head Configuration	
-RD	Rupture disc port with rupture disc assembly & disc
-1/8	One head opening, 1/8" NPT port, plugged
-1/4	One head opening, 1/4" NPT port, plugged
-A	One head opening, "A" socket
-VGR	Valve on gage adapter, pressure gage, rupture disc assembly, & thermocouple (includes thermowell for special alloys)
-NS	Non-standard, custom head opening
G Optional Fittings & Custom Options (List all needed)	
-VD	Single valve on head w/ dip tube (VGR Required)
-DVD	Double valve assembly on head w/ dip tube (VGR Required)
-CL	Cooling Loop
-BDV	Bottom drain valve
-4310A	Gage block assembly (for head with "A" socket opening)
-CAD	Internal Catalyst Addition Device
-XCAD	External Catalyst Addition Device
-SCP	Solids Charging Port (Ball Valve)
-RC	Reflux Condenser
-RTC	Reflux/Take-Off Condenser
-WJ	Welded Jacket

H Pressure Gage Option (VGR and Gage Block only)	
-No Symbol	None
-3000	3000 psi / 207 bar
-2000	2000 psi / 138 bar
-1000	1000 psi / 69 bar
-600	600 psi / 40 bar
-200	200 psi / 14 bar
-100	100 psi / 7 bar
I Stand and Heater Options	
-No Symbol	None
-NS	Heater only, no stand (Temperatures up to 350 °C)
-BTS	Bench top stand with heater
<i>See Section "G" for Welded Jacket option</i>	
J Controller	
-4838	PID Control, Ramp & Soak Programming, and Data logging with Software (RS-485 to USB cable not included). For use with one additional display module.
-4848	PID Control, Ramp & Soak Programming, and Data logging with Software. (RS-485 to USB cable not included). For use with up to three additional display modules.
<i>See Chapter 6 for complete list of Controller options.</i>	
K Controller Options	
-PDM	Pressure Display Module
-HTM	High Temperature Cut Off Module
-ETLM	External Temperature Limit Module
-SVM	Solenoid Valve Module (for cooling control)
-A1925E4	RS-485 to USB Cable for 4838/4848 Controller (required for data logging)
-A1925E6	RS-485 to USB Converter, isolated, 30-ft
-A2208E	RS-485 Daisy Chain for Multiple Controllers (Must be used with A1925E6)
-A3504HC	SpecView Software Package for 4838/4848 Controller
L Electrical Supply for Heater and/or Controller	
-No Symbol	None
-115	115V
-230	230V
M Certifications	
-ASME	ASME Documentation
-CE	CE Documentation
-P	Parr Certification

Series Number:

# 4600

Type:  
**General Purpose**

Stand:  
**Bench Top**

Mounting Style:  
**Moveable or  
Fixed Head**

Sizes, mL:  
**1000 and 2000  
970 and 1900 HP**

Standard Pressure  
MAWP Rating, psi (bar):  
**1900 (131)**

Standard Maximum  
Operating Temp., °C:  
**225 w/ FKM O-ring  
300 w/ FFKM O-ring  
350 w/ PTFE Flat Gasket**

High Pressure (HP)  
MAWP Rating, psi (bar):  
**2900 (200)**

Maximum Operating  
Temperature, °C at  
High Pressure (HP):  
**350 @ 2900 psi**

## Series 4600 Pressure Vessel Systems, 1 & 2 Liter

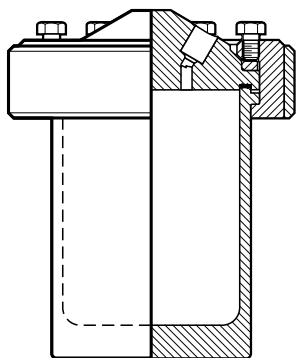

**4600-1L Cross Section**

**The Series 4600, 1.0 and 2.0 L Vessels are the largest of the Parr Vessels that can be handled on a bench top.**

These reactors are available with an FKM O-ring seal for operating temperatures to 225 °C, and FFKM O-ring for temperatures to

300 °C, or with a flat, PTFE gasket for operating temperatures up to 350 °C maximum. An optional HP (High Pressure) flat gasket version has been added for maximum allowable working pressure of 2900 psi (200 bar) at 350 °C. Both fixed head and moveable vessel designs are available.

An optional pneumatic lift is available for the heavier 2 liter cylinder and heater. It should be noted, however, that the 2 liter, fixed head model is tall and may not be convenient to operate on a standard height bench top. We recommend using a floor stand.

With their larger diameter, these mid-size reactors have sufficient space for special modifications, such as an internal cooling coil, bottom drain valve (not on 2 liter bench top), ball valve for a solids charging port, catalyst addition devices, condensers, electrical feed-throughs and more.



**4600-1L Pressure Vessel with Valve, Gage, Rupture Disc, and Thermowell (VGR) and single inlet valve (-VD)**



**4600-1L with Rupture Disc Assembly**

# 4600

Series 4600 Pressure Vessel Specifications				
Shaded bar indicates specifications that change within series.				
Model Number	4600			
Approximate Volume, mL	1000	2000	970	1900
Maximum Pressure (MAWP)	1900 psi (131 bar)		2900 psi (200 bar)	
Maximum Temperature				
with FKM O-ring	225 °C		N/A	
with FFKM O-ring	300 °C			
with PTFE Flat Gasket	350 °C			
with Flexible Graphite Flat Gasket	350 °C			
Vessel Details				
Mounting Style	Moveable or Fixed Head			
Closure	Split-Ring (6 Compression Bolts for Flat Gasket, No Compression Bolts for O-ring)		Split-Ring with 12 Compression Bolts	
Head Opening Options	One head opening (1/8" NPT, 1/4" NPT, "B" socket, or rupture disc assembly port) Ports for valve, gage, rupture disc, and thermowell with thermocouple (VGR) Custom port option (Contact our technical sales department to discuss options)			
Maximum Head Openings	7 (Dependent on opening size, and required fittings)			
Valve Connections	1/8" Male NPT			
Pressure Gage, Size	4.5" Diameter			
Range	0-2000 psi (138 bar)		0-3000 psi (207 bar)	
Temperature Measurement	Thermowell			
Cooling Coil (Optional)	Serpentine			
Bottom Drain Valve (optional, requires stand)	3/8" NPT		1/4" NP	
Stand and Heater (optional)				
Stand Type*	Bench Top Heater with Base Plate (Also Available: Bench Top Stand, Floor Stand, Floor Stand w/ Pneumatic Lift, Floor Cart)			
Heater Style, Bench Top Heater	Calrod			
Heater Power, Watts (115V / 230V)	1000	1350 / 1500	1000	1350 / 1500
Maximum Load, amps, (115V / 230V)	8 / 4	11 / 6	8 / 4	11 / 6
*Heater watts and amps vary between different stand with heater styles, contact Parr Technical Support for more information.				
Weights & Dimensions				
Cylinder I.D. x Depth, inches	4.0 x 5.4	4.0 x 10.5	3.75 x 5.4	3.75 x 10.5
Vessel Assembly w/Moveable Head Weight, pounds**	22	27	26	34
Vessel Assembly w/Fixed Head Weight, pounds**	25	30	28	35
Cylinder Weight, pounds	8.9	14	11	18
**Vessel Assembly weight varies based on head configuration choice and fitting options. Weights shown are based on vessels with valve, gage, rupture disc, thermocouple, and double valve assembly.				
Other options available. See Ordering Guide, visit <a href="http://www.parrinst.com">www.parrinst.com</a> , or call for more information.				

Series Number:

# 4600

## Series 4600 Pressure Vessel Systems

### Index to Options

Option	Page
Certification	8
Materials of Construction	10
Magnetic Drive	14
Gaskets & Seals	18
Stirrer Motor	118
Rupture Disc	124
Pressure Gage	125
Cooling Coil	129
Bottom Drain Valve	131
4848 Reactor Controller	102
4871 Process Controller	109
A2110E Motor Controller	114

### Custom Option

Custom Option	Page
Stirrers	120
Heaters	116
External Valves & Fittings	138
Solids Charging Ports	128
Condensers	123
Electrical Glands	137
Catalyst Addition Device	128
Catalyst Baskets	122
Relief Valves	125
Windows	136
Gear Drives	119
Explosion Proof Options	134
Liquid Sampling	130

### Accessories

Accessories	Page
Liners	129
Spare Parts Kits	137
Pressure Hoses	133
Check Valves	125
Liquid Pipettes	127
Gas Burettes	126



4600-2L-VGR Vessel with bench top heater (-BTH) and base plate

4600-2L-VGR Vessel, Moveable Head



# Series 4600 Ordering Guide

An example order number for a vessel in this series is: **4600-1L-T-SS-VGR-2000**

A composite identification number to be used when ordering a 4600 Series Pressure Vessel System can be developed by combining individual symbols from the separate sections below. For more information on how to use this ordering guide, [please see page 27](#).

A Vessel Rating	
-No Symbol	Standard rating, 1900 psi at 350 °C (1 & 2 Liter Vessels)
-HP	High pressure rating, 2900 psi at 350 °C (970 & 1900 mL Vessels)

B Vessel Volume	
-1000mL	1000 mL, 4" ID (standard rating only)
-2000mL	2000 mL, 4" ID (standard rating only)
-970mL	970 mL, 3.75" ID (high pressure rating only)
-1900mL	1900 mL, 3.75" ID (high pressure rating only)

C Head Mounting Style	
-No Symbol	Moveable Head (Standard configuration)
-FH	Fixed Head

D Gasket / Maximum Temperature	
-T	PTFE Flat Gasket, 350 °C
-OV	FKM O-ring, 225 °C
-OK	FFKM O-ring, 300 °C
-FG	Flexible Graphite Flat Gasket, 350 °C

E Vessel Material of Construction	
-SS	T316 Stainless Steel
-C20	Alloy 20
-MO	Alloy 400
-IN600	Alloy 600
-IN625	Alloy 625
-HB	Alloy B-2 / B-3
-HC	Alloy C-276
-NI	Nickel 200
-TI2	Titanium Grade 2
-TI4	Titanium Grade 4
-ZR702	Zirconium Grade 702
-ZR705	Zirconium Grade 705

See [page 10](#) or [24](#) for complete list of available alloys.

F Head Configuration	
-RD	Rupture disc port with rupture disc assembly & disc
-1/8	One head opening, 1/8" NPT port, plugged
-1/4	One head opening, 1/4" NPT port, plugged
-B	One head opening, "B" socket
-VGR	Valve on gage adapter, pressure gage, rupture disc assembly, & thermocouple w/thermowell
-NS	Non-standard, custom head opening

G Optional Fittings & Custom Options (List all needed)	
-VD	Single valve on head w/ dip tube (VGR Required)
-DVD	Double valve assembly on head w/ dip tube (VGR Required)
-SC	Serpentine cooling coil
-BDV	Bottom drain valve
-4310B	Gage block assembly (for head with "A" socket opening)
-CAD	Internal Catalyst Addition Device
-XCAD	External Catalyst Addition Device
-SCP	Solids Charging Port (Ball Valve)
-RC	Reflux Condenser
-RTC	Reflux/Take-Off Condenser
-WJ	Welded Jacket

H Pressure Gage Option (VGR and Gage Block only)	
-No Symbol	None
-3000	3000 psi / 207 bar
-2000	2000 psi / 138 bar
-1000	1000 psi / 69 bar
-600	600 psi / 40 bar
-200	200 psi / 14 bar
-100	100 psi / 7 bar

I Stand and Heater Options	
-No Symbol	None
-BTH	Bench top heater with base plate (moveable head only)
-BTS	Bench top stand (moveable or fixed head)
-FC	Floor cart (moveable head only)
-FS	Floor stand (moveable or fixed head)
-FSP	Floor stand with pneumatic lift (fixed head only)

J Controller	
-No Symbol	None
-4838	PID Control, Ramp & Soak Programming, and Data logging with Software (RS-485 to USB cable not included). For use with one additional display module.
-4848	PID Control, Ramp & Soak Programming, and Data logging with Software. (RS-485 to USB cable not included). For use with up to three additional display modules.

See [Chapter 6](#) for complete list of Controller options.

K Controller Options	
-PDM	Pressure Display Module
-HTM	High Temperature Cut Off Module
-ETLM	External Temperature Limit Module
-SVM	Solenoid Valve Module (for cooling control)
-A1925E4	RS-485 to USB Converter (required for data logging)
-A1925E6	RS-485 to USB Converter, isolated
-A3504HC	SpecView Software Package

L Electrical Supply for Heater and/or Controller	
-No Symbol	None
-115	115V Heater
-230	230V Heater

M Certifications	
-ASME	ASME Documentation
-CE	CE Documentation
-P	Parr Certification

Series Number:

# 4625

Type:  
**High Pressure**

Stand:  
**Floor Stand or Bench Top**

Mounting Style:  
**Moveable or Fixed Head**

Vessel Sizes, mL:  
**600 and 1200**

High Pressure  
MAWP Rating, psi (bar):  
**5000 (345)**

Standard Maximum  
Operating Temperature, °C:  
**350 w/ PTFE Flat Gasket**

## Series 4625 High Pressure Vessel Systems, 600 & 1200 mL



4625 Cross Section

**This series of vessels has been designed** for users who need higher operating pressures than the 2000 to 3000 psi offered by the General Purpose Reactors, but do not require the high operating temperatures provided by the

Series 4650 High Pressure, High Temperature Reactors. These reactors offer working pressures to 5000 psi (345 bar) at temperatures to 350 °C.

These vessels have been designed with outside dimensions comparable to the Series 4600 so that they can use the same support system and heater as these popular general purpose models.

This provides not only an attractively priced high pressure/moderate temperature system, but also reactors that can be interchanged with the 1 and 2 liter sizes. The thicker walls required for higher operating pressures reduce the volumes of these reactors to 600 and 1200 mL.

These vessels can be used in either the bench top, floor stand, or moveable cart mountings. While the 1200 mL reactor is offered as a fixed head bench top model, it is too tall and too heavy to be handled comfortably on a standard height bench top. It is recommended that a floor stand support option should be selected unless the user has an adjustable bench top which will accommodate the overall height of the 1200 mL systems.



Model 4625-1200mL-VGR-DVD Vessel

Series 4625 Pressure Vessel Specifications		
Shaded bar indicates specifications that change within series.		
Model Number	4625	
Approximate Volume, mL	600	1200
Maximum Pressure (MAWP)	5000 psi (345 bar)	
Maximum Temperature		
with PTFE Flat Gasket	350 °C	
with Flexible Graphite Flat Gasket	350 °C	
Vessel Details		
Mounting Style	Moveable or Fixed Head	
Closure	Split-Ring with 8 Compression Bolts	
Head Opening Options	One Head opening (1/8" NPT, 1/4" NPT, "B" socket, or rupture disc assembly port) Ports for valve, gage, rupture disc, and thermowell with thermocouple (VGR) Custom port option (Contact our technical sales department to discuss options)	
Maximum Head Openings	7 (Dependent on opening size, and required fittings)	
Valve Connections	1/4" Male NPT	
Pressure Gage, Size	4.5" Diameter	
Range	0-5000 psi (345 bar)	
Temperature Measurement	Thermowell	
Cooling Coil (optional)	Serpentine or Loop	
Bottom Drain Valve (BDV) (optional)	1" NPS (Floor Stand or Moveable Cart Only)	
Stand and Heater (optional)		
Stand Type*	Bench Top Heater with Base Plate (Also Available: Bench Top Stand, Floor Stand, Floor Stand w/ Pneumatic Lift, Floor Cart)	
Heater Style, Bench Top Heater	Calrod	
Heater Power, Watts	1000	1350 / 1500
Maximum Load, amps, 115V / 230V	8 / 4	11 / 6
*Heater watts and amps vary between different stand with heater styles, contact Parr Technical Support for more information.		
Weight & Dimensions		
Cylinder I.D. x Depth, inches	3.25 x 4.7	3.25 x 9.8
Vessel Assembly w/ Moveable Head, Weight, pounds**	47	58
Vessel Assembly w/ Fixed Head, Weight, pounds**	50	62
Cylinder Weight, pounds	18	29
**Vessel weight is based on a vessel with VGR head fittings. Vessel weight will vary based on head configuration choice and fitting options.		
Other options available. See Ordering Guide, visit <a href="http://www.parrinst.com">www.parrinst.com</a> , or call for more information.		

# Series 4625 Ordering Guide

An example order number for a vessel in this series is: **4625-600mL-T-SS-1/8-21AC4-A22AC3**

A composite identification number to be used when ordering a 4625 Series Pressure Vessel System can be developed by combining individual symbols from the separate sections below. For more information on how to use this ordering guide, [please see page 27](#).

A Vessel Volume	
-600mL	600 mL, 3.25" ID
-1200mL	1200 mL, 3.25"

B Head Mounting Style	
-No Symbol	Moveable Head (Standard configuration)
-FH	Fixed Head

C Gasket / Maximum Temperature	
-T	PTFE Flat Gasket, 350 °C
-FG	Flexible Graphite Flat Gasket, 350 °C

D Material of Construction	
-SS	T316 Stainless Steel
-C20	Alloy 20
-MO	Alloy 400
-IN600	Alloy 600
-IN625	Alloy 625
-HB	Alloy B-2 / B-3
-HC	Alloy C-276
-NI	Nickel 200
-TI2	Titanium Grade 2
-TI4	Titanium Grade 4
-ZR702	Zirconium Grade 702
-ZR705	Zirconium Grade 705

See [page 10](#) or [24](#) for complete list of available alloys.

E Head Configuration	
-RD	Rupture disc port with rupture disc assembly & disc
-1/8	One head opening, 1/8" NPT port, plugged
-1/4	One head opening, 1/4" NPT port, plugged
-B	One head opening, "B" socket
-VGR	Valve on gage adapter, pressure gage, rupture disc assembly, & thermocouple and thermowell
-NS	Non-standard, custom head opening

F Optional Fittings & Custom Options (List all needed)	
-VD	Single Valve on head w/ dip tube (VGR Required)
-DVD	Double Valve Assembly on head w/ dip tube (VGR Required)
-SC	Serpentine Cooling Coil
-BDV	Bottom Drain Valve
-4310B	Gage Block Assembly (for head with "A" socket opening)
-CAD	Internal Catalyst Addition Device
-XCAD	External Catalyst Addition Device
-SCP	Solids Charging Port (Ball Valve)
-RC	Reflux Condenser
-RTC	Reflux/Take-Off Condenser
-WJ	Welded Jacket

G Pressure Gage Option (VGR required)	
-No Symbol	None
-10000	10000 psi / 690 bar
-7500	7500 psi / 517 bar
-5000	5000 psi / 345 bar
-3000	3000 psi / 207 bar

H Stand and Heater Options	
-No Symbol	None
-BTH	Bench top heater with base plate (moveable head only)
-BTS	Bench top stand (moveable or fixed head)
-FC	Floor cart (moveable head only)
-FS	Floor stand (moveable or fixed head)
-FSP	Floor stand with pneumatic lift (fixed head only)

I Controller	
-No Symbol	None
-4838	PID Control, Ramp & Soak Programming, and Data logging with Software (RS-485 to USB cable not included). For use with one additional display module.
-4848	PID Control, Ramp & Soak Programming, and Data logging with Software. (RS-485 to USB cable not included). For use with up to three additional display modules.

See [Chapter 6](#) for complete list of Controller options.

J Controller Options	
-PDM	Pressure Display Module
-HTM	High Temperature Cut Off Module
-ETLM	External Temperature Limit Module
-A1925E4	RS-485 to USB Converter (required for data logging)
-A1925E4	RS-485 to USB Converter, isolated
-A3504HC	SpecView Software Package

K Electrical Supply for Heater and/or Controller	
-No Symbol	None
-115	115V Heater
-230	230V Heater

L Certifications	
-ASME	ASME Documentation
-CE	CE Documentation
-P	Parr Certification

Model 4625-1200mL Vessel w/ Bench Top Heater (BTH)



Series Number:

**4650**Type:  
**High Pressure  
High Temperature**Stand:  
**Bench Top**Mounting Style:  
**Moveable or  
Fixed Head**Vessel Sizes, mL:  
**250-1000**High Pressure  
MAWP Rating, psi (bar):  
**4200 (290)**Standard Maximum  
Operating Temperature, °C:  
**500 w/ Grafoil Gasket**High Temperature  
Maximum Operating  
Temperature, °C:  
**600 w/ Grafoil Gasket**

# Series 4650 High Pressure / High Temperature Vessel Systems

**4650 Series High Pressure and High Temperature Vessels** are available in volumes of 250, 500, and 1000 mL. These vessels can obtain temperatures up to 600 °C and a maximum pressure of 6000 psi (410 bar). The maximum pressure at maximum temperature is 4200 psi (290 bar) at 600 °C. They come standard with a Split Ring Closure with 8 Compression bolts, and a VGR head design that includes Valve, Gage, Rupture Disc, and Thermowell. An additional valve with dip tube can be added.

The maximum allowable head openings are seven but this may be limited by the types of fittings required. These vessels are available as either a moveable or fixed head design.

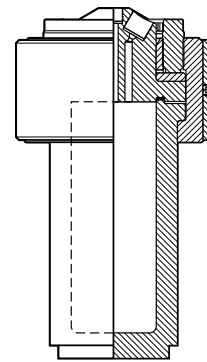
**4650-1000mL Cross Section**

<b>Series 4650 Pressure Vessel Specifications</b>			
Shaded bar indicates specifications that change within series.			
<b>Model Number</b>	<b>4650</b>		
<b>Approximate Volume, mL</b>	250	500	1000
<b>Maximum Pressure (MAWP)</b>	5000 psi (345 bar) @ 500 °C 6000 psi (413 bar) @ 350 °C 4200 psi (289 bar) @ 600 °C		
<b>Maximum Temperature</b>			
with PTFE Flat Gasket	350 °C		
with Flexible Graphite Flat Gasket	500-600 °C		
<b>Vessel Details</b>			
Mounting Style	Moveable or Fixed Head		
Closure	Split-Ring (8 Compression Bolts)		
Head Opening Options	Ports for valve, gage, rupture disc, and thermocouple (VGR) Custom port option (Contact our technical sales department to discuss options)		
Maximum Head Openings	7 (Dependent on opening size, and required fittings)		
Valve Connections	1/4" NPT Female		
Pressure Gage, Size	4.5 inches		
Range	0-5000 psi (345 psi) or 0-7500 psi (517 bar)		
Temperature Measurement	Thermowell		
Cooling Coil (optional)	Single Loop		
<b>Stand and Heater (optional)</b>			
Stand Type	Bench Top Heater with base plate (moveable head only) and Bench Top Stand with Heater (fixed head)		
Heater Style	Ceramic Fiber Heater		
Heater Power, Watts	1500		
Maximum Load, amps, 115V / 230V	15 / 9		
<b>Weights &amp; Dimensions</b>			
Cylinder I.D. x Depth, inches	2.5 x 3.25	2.5 x 6.63	2.5 x 13.13
Vessel Assembly w/ Moveable Head Weight, pounds**	38	45	57
Vessel Assembly w/ Fixed Head Weight, pounds**	33	40	52
Cylinder Weight, pounds	8.9	15	26
** Vessel Assembly weight varies based on head configuration choice and fitting options. Weights shown are based on vessels with valve, gage, rupture disc, thermocouple, and double valve assembly.			
Other options available. See Ordering Guide, visit <a href="http://www.parrinst.com">www.parrinst.com</a> , or call for more information.			

# Series 4650 Ordering Guide

An example order number for a vessel in this series is: **4650-250mL-FG-SS-VGR-VD-5000**

A composite identification number to be used when ordering a 4650 Series Pressure Vessel System can be developed by combining individual symbols from the separate sections below. For more information on how to use this ordering guide, please see page 27.

A Vessel Volume	
-250mL	250 mL, 2.5" ID
-500mL	500 mL, 2.5" ID
-1000mL	1000 mL, 2.5" ID

B Head Mounting Style	
-No Symbol	Moveable Head (Standard configuration)
-FH	Fixed Head

C Gasket / Maximum Temperature	
-T	PTFE Flat Gasket, 350 °C
-FG	Flexible Graphite Flat Gasket, 350 °C

D Material of Construction	
-SS	T316 Stainless Steel
-C20	Alloy 20*
-MO	Alloy 400*
-IN600	Alloy 600
-IN625	Alloy 625
-HB	Alloy B-2 / B-3*
-HC	Alloy C-276
-NI	Nickel 200
-TI2	Titanium Grade 2*
-TI4	Titanium Grade 4*
-ZR702	Zirconium Grade 702*
-ZR705	Zirconium Grade 705*

\*High temperature option not available.  
See page 10 or 24 for complete list of available alloys.

E Head Configuration	
-VGR	Valve on gage adapter, pressure gage, rupture disc assembly, & thermocouple and thermowell
-NS	Non-standard, custom head opening

F Optional Fittings & Custom Options (List all needed)	
-VD	Single Valve on head w/ dip tube (VGR Required)
-DVD	Double Valve Assembly on head w/ dip tube (VGR Required)
-CL	Cooling Loop
-BDV	Bottom Drain Valve
-CAD	Internal Catalyst Addition Device
-XCAD	External Catalyst Addition Device
-SCP	Solids Charging Port (Ball Valve)
-RC	Reflux Condenser
-RTC	Reflux/Take-Off Condenser
-WJ	Welded Jacket

G Pressure Gage	
-No Symbol	None
-10000	10000 psi / 690 bar
-7500	7500 psi / 517 bar
-5000	5000 psi / 345 bar
-3000	3000 psi / 207 bar
-2000	2000 psi / 138 bar

H Stand and Heater Options	
-No Symbol	None
-BTH	Bench Top heater with base plate
-BTS	Bench Top Stand with Heater

I Controller	
-No Symbol	None
-4838	PID Control, Ramp & Soak Programming, and Data logging with Software (RS-485 to USB cable not included). For use with one additional display module.
-4848	PID Control, Ramp & Soak Programming, and Data logging with Software. (RS-485 to USB cable not included). For use with up to three additional display modules.

See Chapter 6 for complete list of Controller options.

J Controller Options (Check all needed)	
-PDM	Pressure Display Module
-HTM	High Temperature Cut Off Module
-ETLM	External Temperature Limit Module
-SVM	Solenoid Valve Module (for cooling control)
-A1925E4	RS-485 to USB Converter (required for data logging)
-A1925E6	RS-485 to USB Converter, isolated, 30-ft
-A2208E	RS-485 Daisy Chain for Multiple Controllers (Must be used with A1925E6)
-A3504HC	SpecView Software Package

K Electrical Supply for Heater and/or Controller	
-No Symbol	None
-115	115V Heater
-230	230V Heater

L Certifications	
-No Symbol	No Certification
-ASME	ASME Documentation
-CE	CE Documentation
-P	Parr Certification



Model 4650-250mL Vessel with VGR, Thermocouple, and Single Inlet Valve (-VD)

Model 4650-500mL Removeable Head Vessel with Bench Top Heater and Base Plate

Series Number:

# 4660

Type:  
**General Purpose**

Stand:  
**Floor Stand**

Mounting Style:  
**Moveable or Fixed Head**

Vessel Sizes, Gallons (Liters)  
**1 (3.75) and 2 (7.99)**

Standard Pressure  
MAWP Rating, psi (bar):  
**1900 (131)**

Standard Maximum  
Operating Temp., °C:  
**225 w/ FKM O-ring**  
**300 w/ FFKM O-ring**  
**350 w/ PTFE Flat Gasket**

## Series 4660 Pressure Vessel Systems, 1 & 2 Gallon

**The 4660 Vessels extend the range of Parr Pressure Vessels to 1 and 2 gallon (3.75 and 7.99 liter) sizes.**

These vessels are available with an FKM O-ring seal for operating temperatures to 225 °C, and FFKM O-ring for temperatures to 300 °C, or with a flat, PTFE gasket for operating temperatures up to 350 °C maximum.

Both fixed head and moveable head designs are available. The moveable head vessels are designed so that they can be opened or closed conveniently without removing the cylinder from the heater and without auxiliary handling equipment. The split-ring cover clamp sections can be moved into place from the sides, and the compression bolts can be tightened with the vessel in place in its heater. The fixed head versions allow the head (and the connections made to it) to remain in place while the cylinder and heater are lowered with the aid of the included pneumatic lift system.

An optional bottom drain valve may be added for convenient product recovery. As with the smaller floor stand models, these larger, self-contained systems can be equipped with a variety of attachments, such as condensers, solids charging ports, bottom drains, special heaters, jacketed vessels and automatic valves and regulators. Because of the higher wattage heaters for these reactors, all models in this series require a 230 volt power supply.

Series 4660 Pressure Vessel Specifications		
Shaded bar indicates specifications that change within series.		
Model Number	4660	
Approximate Volume, Gallon (Liter)	1 (3.75)	2 (7.99)
Maximum Pressure (MAWP)	1900 psi (131 bar)	
<b>Maximum Temperature</b>		
with FKM O-Ring	225 °C	
with FFKM O-Ring	300 °C	
with PTFE Flat Gasket	350 °C	
with Flexible Graphite Flat Gasket	350 °C	
<b>Vessel Details</b>		
Mounting Style	Moveable or Fixed Head	
Closure	Split-Ring with 10 Compression Bolts, no Compression Bolts for O-ring	
Head Opening Options	One head opening (1/4" NPT or rupture disc assembly port) Ports for valve, gage, rupture disc, and thermowell with thermocouple (VGR) Custom port option (Contact our technical sales department to discuss options)	
Maximum Head Openings	10 (Dependent on opening size, and required fittings)	
Valve Connections	1/4" NPT Female	
Pressure Gage, Size	4.5 inches	
Range	0-2000 psi (138 bar)	
Temperature Measurement	Thermowell	
Cooling Coil (optional)	Serpentine	
Bottom Drain Valve	3/8" NPT	
<b>Stand and Heater (optional)</b>		
Stand Type	Floor Cart with heater (moveable head only) Floor Stand with Pneumatic Lift and heater (fixed head)	
Heater Style	Calrod	
Heater Power, Watts	2250	2750
Maximum Load, amps, 230V	10	12
<b>Weights &amp; Dimensions</b>		
Cylinder I.D. x Depth, inches	6.0 x 8.5	6.0 x 17.1
Vessel Assembly w/ Moveable Head Weight, pounds*	84	103
Vessel Assembly w/ Fixed Head Weight, pounds*	98	117
Cylinder Weight, pounds	33	52
* Vessel Assembly weight varies based on head configuration choice and fitting options. Weights shown are based on vessels with valve, gage, rupture disc, thermowell, and double valve assembly.		
Other options available. See Ordering Guide, visit <a href="http://www.parrinst.com">www.parrinst.com</a> , or call for more information.		

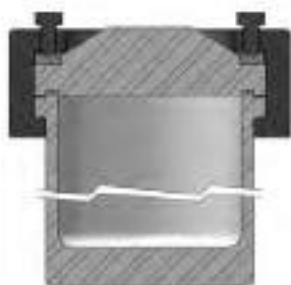

**4660 Cross Section with Flat Gasket Seal**



**4660Q Cross Section with O-ring Seal**

# Series 4660 Ordering Guide

An example order number for a vessel in this series is: **4660-1G-T-SS-VGR-2000**

A composite identification number to be used when ordering a 4660 Series Pressure Vessel System can be developed by combining individual symbols from the separate sections below. For more information on how to use this ordering guide, please see page 27.

A Vessel Volume	
-1G	1 Gallon, 6" ID
-2G	2 Gallon, 6" ID

B Head Mounting Style	
-No Symbol	Moveable Head (Standard configuration)
-FH	Fixed Head

C Gasket / Maximum Temperature	
-T	PTFE Flat Gasket, 350 °C
-FG	Flexible Graphite Flat Gasket, 350 °C

D Material of Construction	
-SS	T316 Stainless Steel
-C20	Alloy 20
-MO	Alloy 400
-IN600	Alloy 600
-IN625	Alloy 625
-HB	Alloy B-2 / B-3
-HC	Alloy C-276
-NI	Nickel 200
-Ti2	Titanium Grade 2
-Ti4	Titanium Grade 4
-ZR702	Zirconium Grade 702
-ZR705	Zirconium Grade 705

See page 10 or 24 for complete list of available alloys.

E Head Configuration	
-1/4	One head opening, 1/4" NPT port, plugged
-RD	Rupture disc port with rupture disc assembly & disc
-VGR	Valve on gage adapter, pressure gage, rupture disc assembly, & thermocouple and thermowell
-NS	Non-standard, custom head opening

F Optional Fittings & Custom Options (List all needed)	
-VD	Single Valve on head w/ dip tube (VGR Required)
-DVD	Double Valve Assembly on head w/ dip tube (VGR Required)
-CL	Cooling Loop
-BDV	Bottom Drain Valve
-CAD	Internal Catalyst Addition Device
-XCAD	External Catalyst Addition Device
-SCP	Solids Charging Port (Ball Valve)
-RC	Reflux Condenser
-RTC	Reflux/Take-Off Condenser
-WJ	Welded Jacket

G Pressure Gage	
-No Symbol	None
-2000	2000 psi / 138 bar
-1000	1000 psi / 69 bar
-600	600 psi / 40 bar
-200	200 psi / 14 bar
-100	100 psi / 7 bar

H Stand and Heater Options	
-No Symbol	None
-FC	Floor Cart with Heater
-FSP	Floor Stand with Pneumatic Lift and heater

I Controller	
-No Symbol	None
-4838	PID Control, Ramp & Soak Programming, and Data logging with Software (RS-485 to USB cable not included). For use with one additional display module.
-4848	PID Control, Ramp & Soak Programming, and Data logging with Software. (RS-485 to USB cable not included). For use with up to three additional display modules.

See Chapter 6 for complete list of Controller options.

J Controller Options (Check all needed)	
-PDM	Pressure Display Module
-HTM	High Temperature Cut Off Module
-ETLM	External Temperature Limit Module
-SVM	Solenoid Valve Module (for cooling control)
-A1925E4	RS-485 to USB Converter (required for data logging)
-A1925E6	RS-485 to USB Converter, isolated, 30-ft
-A2208E	RS-485 Daisy Chain for Multiple Controllers (Must be used with A1925E6)
-A3504HC	SpecView Software Package

K Electrical Supply for Heater and/or Controller	
-No Symbol	None
-230	230V Heater

L Certifications	
-No Symbol	No Certification
-ASME	ASME Documentation
-CE	CE Documentation
-P	Parr Certification



Model 4660-1G Vessel in Floor Cart with Heater and 4848 Controller

Model 4660-2G Vessel, Fixed Head Floor Stand, with Pneumatic Lift and Heater

Series Number:

# 4680

Type:  
**High Pressure  
High Temperature**

Stand:  
**Cart or Floor Stand**

Mounting Style:  
**Moveable or  
Fixed Head**

Vessel Sizes, Liters:  
**1 and 1.8**

High Pressure  
MAWP Rating, psi (bar):  
**6000 (410)**

Standard Maximum  
Operating Temperature, °C:  
**600 w/ Flat FG Gasket**

## Series 4680 High Pressure / High Temperature Vessel Systems, 1 & 1.8 Liters

The **Series 4680 High Pressure/High Temperature Vessels** are available with either a 1.0 L or 1.8 L capacity. These vessels can obtain temperatures up to 600 °C and a maximum pressure of 6000 psi (410 bar). The maximum pressure at maximum temperature is 4200 psi (290 bar) at 600 °C. A Split Ring closure with 12 Compression Bolts secures the head which allows a maximum of 8 openings. The Series 4680 Vessels can be configured with either a fixed head on a floor stand or as a moveable head vessel on a moveable cart. The fixed head versions allow the head (and the connections made to it) to remain in place while the cylinder and heater are lowered with the aid of the included pneumatic lift system.

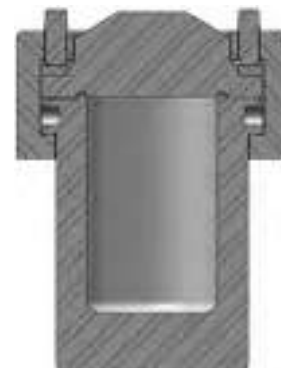

4680 Cross Section

Series 4680 Pressure Vessel Specifications		
Shaded bar indicates specifications that change within series.		
Model Number	4680	
Approximate Volume, mL	1000	1800
Maximum Pressure (MAWP)	5000 psi (345 bar) @ 500 °C 6000 psi (413 bar) @ 350 °C 4200 psi (289 bar) @ 600 °C	
Maximum Temperature		
with PTFE Flat Gasket	350 °C	
with Flexible Graphite Flat Gasket	500-600 °C	
<b>Vessel Details</b>		
Mounting Style	Moveable or Fixed Head	
Closure	Split-Ring with 12 Compression Bolts	
Head Opening Options	One head opening ("B" socket, or rupture disc assembly port) Ports for valve, gage, rupture disc, and thermowell with thermocouple (VGR) Custom port option (Contact our technical sales department to discuss options)	
Maximum Head Openings	8 (Dependent on opening size, and required fittings)	
Valve Connections	1/4" NPT Female	
Pressure Gage, Size	4.5 inches	
Range	0-5000 psi (345 bar) or 0-7500 psi ( 517 bar)	
Temperature Measurement	Thermowell	
Cooling Coil (optional)	Single Loop	
Bottom Drain Valve	1" NPS	
<b>Stand and Heater (optional)</b>		
Stand Type	Floor Cart with heater (moveable head only) Floor Stand with Pneumatic Lift and heater (fixed head)	
Heater Style	Ceramic Fiber	
Heater Power, Watts	2300	2500
Maximum Load, amps, 230V	10	11
<b>Weights &amp; Dimensions</b>		
Cylinder I.D. x Depth, inches	3.75 x 6.12	3.75 x 10.5
Vessel Assembly w/ Moveable Head Weight, pounds*	74	94
Vessel Assembly w/ Fixed Head Weight, pounds*	88	104
Cylinder Weight, pounds	36	52
*Vessel weight is based on a vessel with VGR head fittings. Vessel weight will vary based on head configuration choice and fitting options.		
Other options available. See Ordering Guide, visit <a href="http://www.parrinst.com">www.parrinst.com</a> , or call for more information.		



4680-1800mL Fixed Head Vessel shown with Split Rings open and vessel down using a pneumatic lift.



# Series 4680 Ordering Guide

An example order number for a vessel in this series is: **4680-1000mL-FG-SS-VGR-5000**

A composite identification number to be used when ordering a 4680 Series Pressure Vessel System can be developed by combining individual symbols from the separate sections below. For more information on how to use this ordering guide, please see page 27.

A Vessel Volume	
-1000mL	1000 mL, 3.75" ID
-1800mL	1800 mL, 3.75" ID

B Head Mounting Style	
-No Symbol	Moveable Head (Standard configuration)
-FH	Fixed Head

C Gasket / Maximum Temperature	
-T	PTFE Flat Gasket, 350 °C
-FG	Flexible Graphite Flat Gasket, 350 °C

D Material of Construction	
-SS	T316 Stainless Steel
-C20	Alloy 20
-MO	Alloy 400
-IN600	Alloy 600
-IN625	Alloy 625
-HB	Alloy B-2 / B-3
-HC	Alloy C-276
-NI	Nickel 200
-TI2	Titanium Grade 2
-TI4	Titanium Grade 4
-ZR702	Zirconium Grade 702
-ZR705	Zirconium Grade 705

See page 10 or 24 for complete list of available alloys.

E Head Configuration	
-B	One head opening, "B" socket
-RD	Rupture disc port with rupture disc assembly & disc
-VGR	Valve on gage adapter, pressure gage, rupture disc assembly, & thermocouple and thermowell
-NS	Non-standard, custom head opening

F Optional Fittings & Custom Options (List all needed)	
-VD	Single Valve on head w/ dip tube (VGR Required)
-DVD	Double Valve Assembly on head w/ dip tube (VGR Required)
-CL	Cooling Loop
-BDV	Bottom Drain Valve
-4310B	Gage Block Assembly (for head with "B" socket opening)
-CAD	Internal Catalyst Addition Device
-XCAD	External Catalyst Addition Device
-SCP	Solids Charging Port (Ball Valve)
-RC	Reflux Condenser
-RTC	Reflux/Take-Off Condenser
-WJ	Welded Jacket

G Pressure Gage	
-No Symbol	None
-10000	10000 psi / 690 bar
-7500	7500 psi / 517 bar
-5000	5000 psi / 345 bar
-3000	3000 psi / 207 bar
-2000	2000 psi / 138 bar

H Stand and Heater Options	
-No Symbol	None
-FC	Floor Cart with heater (moveable head only)
-FSP	Floor Stand w/ Pneumatic Lift and heater (fixed head)

I Controller	
-4838	PID Control, Ramp & Soak Programming, and Data logging with Software (RS-485 to USB cable not included). For use with one additional display module.
-4848	PID Control, Ramp & Soak Programming, and Data logging with Software. (RS-485 to USB cable not included). For use with up to three additional display modules.

See Chapter 6 for complete list of Controller options.

J Controller Options (Check all needed)	
-PDM	Pressure Display Module
-HTM	High Temperature Cut Off Module
-ETLM	External Temperature Limit Module
-SVM	Solenoid Valve Module (for cooling control)
-A1925E4	RS-485 to USB Converter (required for data logging)
-A1925E6	RS-485 to USB Converter, isolated, 30-ft
-A2208E	RS-485 Daisy Chain for Multiple Controllers (Must be used with A1925E6)
-A3504HC	SpecView Software Package for 4838/4848 Controller

K Electrical Supply for Heater and/or Controller	
-No Symbol	None
-230	230V Heater

L Certifications	
-No Symbol	No Certification
-ASME	ASME Documentation
-CE	CE Documentation
-P	Parr Certification



4680-1800mL Fixed Head Vessel, double valve w/ dip tube, gas release valve, gage, rupture disc, and thermowell

4680-1800mL Moveable Head High Pressure Vessel in Floor Cart with Heater

Series Number:

**4670**Type:  
**High Pressure  
High Temperature**Stand:  
**Cart or Floor Stand**Mounting Style:  
**Moveable or  
Fixed Head**Vessel Sizes, Gallons (Liters):  
**1 (3.75) and 1.5 (5.8)**Standard Pressure  
MAWP Rating, psi (bar):  
**3000 (200)**Standard Maximum  
Operating Temperature, °C:  
**600 w/ Flat FG Gasket**

## Series 4670 HP-HT Vessel Systems, 1 and 1.5 Gallon

The Series 4670 High Pressure/High Temperature Vessels are available in either a 1.0 or 1.5 Gallon capacity. These vessels can obtain temperatures up to 600 °C and a maximum pressure of 3000 psi (207 bar). The maximum pressure at maximum temperature is 2200 psi (151 bar) at 600 °C. A Split Ring closure with 16 Compression Bolts secures the head which allows a maximum of 12 openings. The Series 4670 Vessels can be configured with either a fixed head on a floor stand or as a moveable head vessel on a moveable cart. The fixed head versions allow the head (and the connections made to it) to remain in place while the cylinder and heater are lowered with the aid of the included pneumatic lift system.

**4670 Cross Section**

Series 4670 Pressure Vessel Specifications		
Shaded bar indicates specifications that change within series.		
Model Number	4670	
Approximate Volume, Gallon (Liter)	1 (3.75)	1.5 (5.8)
Maximum Pressure (MAWP)	3000 psi (207 bar, 200 bar for CE orders) @ 500 °C 2200 psi (151 bar) @ 600 °C	
Maximum Temperature		
with PTFE Flat Gasket	350 °C	
with Flexible Graphite Flat Gasket	500-600 °C	
Vessel Details		
Mounting Style	Moveable or Fixed Head	
Closure	Split-Ring with 16 Compression Bolts	
Head Opening Options	One head opening (rupture disc assembly port) Ports for valve, gage, rupture disc, and thermowell with thermocouple (VGR) Custom port option (Contact our technical sales department to discuss options)	
Maximum Head Openings	12 (Dependent on opening size, and required fittings)	
Valve Connections	1/4" NPT Female	
Pressure Gage, Size	4.5 inches	
Range	0-3000 psi (207 bar)	
Temperature Measurement	Thermowell	
Cooling Coil (optional)	Serpentine	
Bottom Drain Valve (BDV) (optional)	1" NPS (Floor Stand or Moveable Cart Only)	
Stand and Heater (optional)		
Stand Type*	Floor Cart with heater (moveable head only) Floor Stand with Pneumatic Lift and heater (fixed head)	
Heater Style	Ceramic Fiber	
Heater Power, Watts	2800	
Maximum Load, amps, 230V	12	
*Heater watts and amps vary between different heater styles, contact Parr Technical Support for more information.		
Weights & Dimensions		
Cylinder I.D. x Depth, inches	5.5 x 9.75	5.5 x 15.0
Vessel Assembly w/ Moveable Head Weight, pounds*	113	131
Vessel Assembly w/ Fixed Head Weight, pounds*	124	143
Cylinder Weight, pounds	3653	72
*Vessel weight is based on a vessel with VGR head fittings. Vessel weight will vary based on head configuration choice and fitting options.		
Other options available. See Ordering Guide, visit <a href="http://www.parrinst.com">www.parrinst.com</a> , or call for more information.		

# Series 4670 Ordering Guide

An example order number for a vessel in this series is: **4670-1G-FG-SS-VGR-5000**

A composite identification number to be used when ordering a 4670 Series Pressure Vessel System can be developed by combining individual symbols from the separate sections below. For more information on how to use this ordering guide, please see page 27.

A Vessel Volume	
-1G	1 Gallon, 5.5" ID
-1.5G	1.5 Gallon, 5.5" ID

B Head Mounting Style	
-No Symbol	Moveable Head (Standard configuration)
-FH	Fixed Head

C Gasket / Maximum Temperature	
-T	PTFE Flat Gasket, 350 °C
-FG	Flexible Graphite Flat Gasket, 500 or 600 °C

D Material of Construction	
-SS	T316 Stainless Steel
-C20	Alloy 20*
-MO	Alloy 400*
-IN600	Alloy 600
-IN625	Alloy 625
-HB	Alloy B-2 / B-3*
-HC	Alloy C-276
-NI	Nickel 200
-TI2	Titanium Grade 2*
-TI4	Titanium Grade 4*
-ZR702	Zirconium Grade 702*
-ZR705	Zirconium Grade 705*

\*High temperature option not available.  
See page 10 or 24 for complete list of available alloys.

E Head Configuration	
-RD	Rupture disc port with rupture disc assembly & disc
-VGR	Valve on gage adapter, pressure gage, rupture disc assembly, & thermocouple and thermowell
-NS	Non-standard, custom head opening

F Optional Fittings & Custom Options (List all needed)	
-VD	Single Valve on head w/ dip tube (VGR Required)
-DVD	Double Valve Assembly on head w/ dip tube (VGR Required)
-SC	Serpentine Cooling Coil
-BDV	Bottom Drain Valve (1" NPS)
-CAD	Internal Catalyst Addition Device
-XCAD	External Catalyst Addition Device
-SCP	Solids Charging Port (Ball Valve)
-RC	Reflux Condenser
-RTC	Reflux/Take-Off Condenser

G Pressure Gage	
-No Symbol	None
-5000	5000 psi / 345 bar
-3000	3000 psi / 207 bar
-2000	2000 psi / 138 bar

H Stand and Heater Options	
-No Symbol	None
-FC	Floor Cart with heater (moveable head only)
-FSP	Floor Stand w/ Pneumatic Lift and heater (fixed head)

I Controller	
-4838	PID Control, Ramp & Soak Programming, and Data logging with Software (RS-485 to USB cable not included). For use with one additional display module.
-4848	PID Control, Ramp & Soak Programming, and Data logging with Software. (RS-485 to USB cable not included). For use with up to three additional display modules.

See Chapter 6 for complete list of Controller options.

J Controller Options (Check all needed)	
-PDM	Pressure Display Module
-HTM	High Temperature Cut Off Module
-ETLM	External Temperature Limit Module
-SVM	Solenoid Valve Module (for cooling control)
-A1925E4	RS-485 to USB Converter (required for data logging)
-A1925E6	RS-485 to USB Converter, isolated, 30-ft
-A2208E	RS-485 Daisy Chain for Multiple Controllers (Must be used with A1925E6)
-A3504HC	SpecView Software Package for 4838/4848 Controller

K Electrical Supply for Heater and/or Controller	
-No Symbol	None
-230	230V

L Certifications	
-No Symbol	No Certification
-ASME	ASME Documentation
-CE	CE Documentation
-P	Parr Certification



Model 4670-1.5G Moveable Head Vessel on a Floor Cart with Heater and 4848 Controller

Series Number:

# 4675

Type:  
**General Purpose**

Stand:  
**Floor Stand**

Mounting Style:  
**Moveable or  
Fixed Head**

Vessel Sizes, Gallons (Liters):  
**2.6 (10) and 5 (18.75)**

Standard Pressure  
MAWP Rating, psi (bar):  
**1900 (131)**

Standard Maximum  
Operating Temperature, °C:  
**225 w/ FKM O-ring**  
**300 w/ FFKM O-ring**  
**350 w/ PTFE Flat Gasket**

## Series 4675 General Purpose Vessel Systems, 2.6 & 5 Gallon

**The Series 4675 General Purpose Vessels are the largest vessels offered by Parr Instrument Company.** Vessel styles are offered in a moveable head or fixed head design. These vessels are available with an FKM O-ring seal for operating temperatures to 225 °C, and FFKM O-ring for temperatures to 300 °C, or with a flat, PTFE gasket for operating temperatures up to 350 °C maximum.

In the moveable head design, the vessel is held in a support system which minimizes the physical effort required to handle these heavy components. The hoist is attached to a support column which provides a convenient means for lifting the head and cylinder out of the stand. Vessels equipped with a bottom drain valve will probably remain in the heater most of the time, but can be lifted out when necessary.

The fixed head support stand features hinged split-rings that swing to either side allowing the head to remain fixed to the stand while a pneumatic lift allows the cylinder to be raised and lowered. When lowered, the cylinder can be slid forward for cleaning and servicing.

These vessels are generally used for pilot plant or for custom chemical production purposes, usually with a variety of attachments added to the basic units.

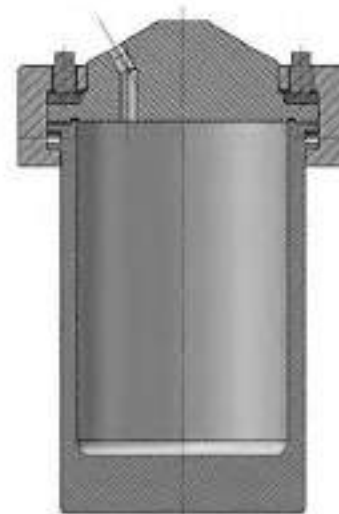

4675 Cross Section



Model 4675-10L General Purpose Vessel

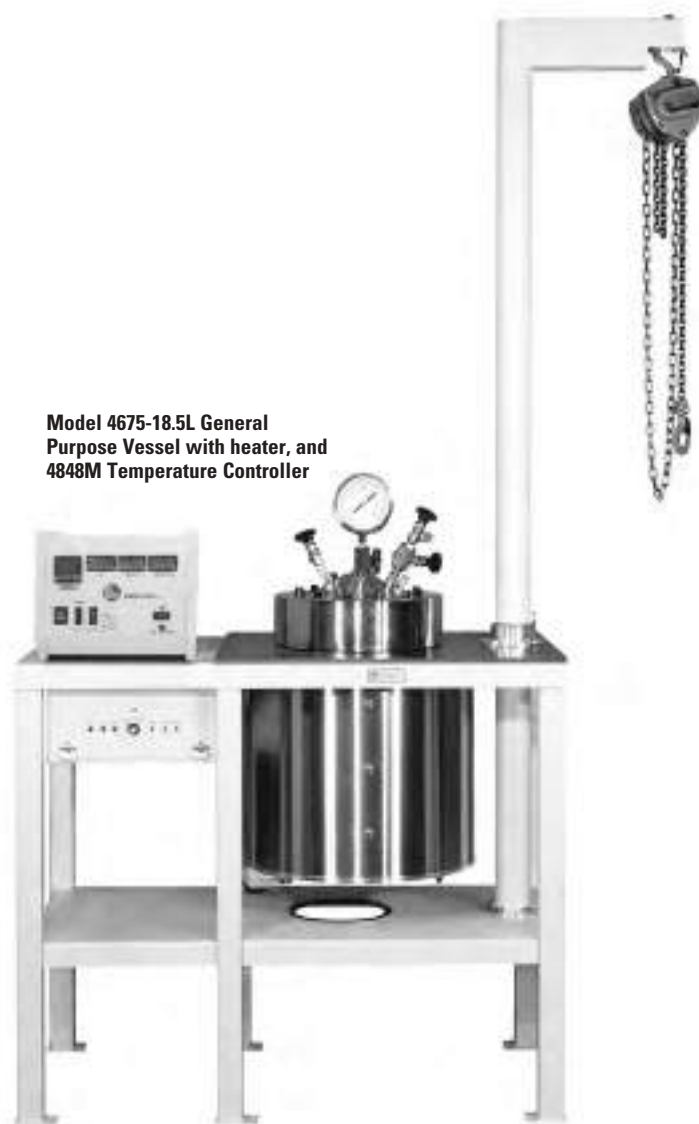

Model 4675-18.5L General Purpose Vessel with heater, and 4848M Temperature Controller

# 4675

Series 4675 Pressure Vessel Specifications		
Shaded bar indicates specifications that change within series.		
<b>Model Number</b>	<b>4675</b>	
<b>Approximate Volume, Gallon (Liter)</b>	5 (18.75)	2.6 (10)
<b>Maximum Pressure (MAWP)</b>	1900 psi (131 bar)	
<b>Maximum Temperature</b>		
with FKM O-Ring	225 °C	
with FFKM O-Ring	300 °C	
with PTFE Flat Gasket	350 °C	
with Flexible Graphite Flat Gasket	350 °C	
<b>Vessel Details</b>		
Mounting Style	Moveable or Fixed Head	
Closure	Split-Ring with 12 Compression Bolts	Split-Ring with 12 Compression Bolts
Head Opening Options	One head opening (1/4" NPT, 3/8" NPT, or rupture disc assembly port) Ports for valve, gage, rupture disc, and thermowell with thermocouple (VGR) Custom port option (Contact our technical sales department to discuss options)	
Maximum Head Openings	12 (Dependent on opening size, and required fittings)	
Valve Connections	1/4" NPT Female	
Pressure Gage, Size	4.5 inches	
Range	0-2000 psi (138 bar)	
Temperature Measurement	Thermowell	
Cooling Coil (optional)	Serpentine	
Bottom Drain Valve (BDV) (optional)	1" NPT	
<b>Stand and Heater (optional)</b>		
Stand Type	Table Floor Stand with manual hoist (moveable head) Floor Stand with Pneumatic Lift (fixed head)	
Heater Options	Band Heater, 3-zone Ceramic, 3-zone (moveable head) Flexible Mantle Heater (low temperatures <200 °C)	Band Heater, 3-zone Flexible Mantle Heater (low temperatures <200 °C)
Heater Power Requirements	Typical power requirements for Parr's large, electrically heated pressure vessels are 40 Amp single phase or 3-Phase power sources. Users are advised to have a qualified electrician determine and install an appropriate mains power supply for the large pressure vessel system. Large pressure vessel systems with lower electrical power requirements, such as low temperature applications are available for use with typical 20 amp 230 volt sources. Contact Parr Technical Sales staff for assistance with electrical specifications.	
<b>Weights &amp; Dimensions</b>		
Cylinder I.D. x Depth, inches	9.5 x 16.25	7.75 x 12.2
Moveable Vessel Assembly Weight, pounds*	335	194
Fixed Vessel Assembly Weight, pounds*	336	195
Cylinder Weight, pounds	157	97
*Vessel weight is based on a vessel with VGR head fittings. Vessel weight will vary based on head configuration choice and fitting options.		
Other options available. See Ordering Guide, visit <a href="http://www.parrinst.com">www.parrinst.com</a> , or call for more information.		

# Series 4675 Ordering Guide

An example order number for a vessel in this series is: **4675-5G-FG-SS-VGR-5000**

A composite identification number to be used when ordering a 4675 Series Pressure Vessel System can be developed by combining individual symbols from the separate sections below. For more information on how to use this ordering guide, [please see page 27](#).

## A Vessel Volume

-2.6G	2.6 Gallon, 7.75" ID
-5G	5 Gallon, 9.5" ID

## B Head Mounting Style

-No Symbol	Moveable Head (Standard configuration)
-FH	Fixed Head

## C Gasket / Maximum Temperature

-T	PTFE Flat Gasket, 350 °C
-OV	FKM O-ring, 225 °C
-OK	FFKM O-ring, 300 °C
-FG	Flexible Graphite Flat Gasket, 350 °C

## D Material of Construction

-SS	T316 Stainless Steel
-C20	Alloy 20
-MO	Alloy 400
-IN600	Alloy 600
-IN625	Alloy 625
-HB	Alloy B-2 / B-3
-HC	Alloy C-276
-NI	Nickel 200
-TI2	Titanium Grade 2
-TI4	Titanium Grade 4
-ZR702	Zirconium Grade 702
-ZR705	Zirconium Grade 705

See [page 10](#) or [24](#) for complete list of available alloys.

## E Head Configuration

-1/4	One head opening, 1/4" NPT port, plugged
-3/8	One head opening, 3/8" NPT port, plugged
-RD	Rupture disc port with rupture disc assembly & disc
-VGR	Valve on gage adapter, pressure gage, rupture disc assembly, & thermocouple and thermowell
-NS	Non-standard, custom head opening

## F Optional Fittings & Custom Options (List all needed)

-VD	Single Valve on head w/ dip tube (VGR Required)
-DVD	Double Valve Assembly on head w/ dip tube (VGR Required)
-SC	Serpentine Cooling Coil
-BDV	Bottom Drain Valve (1" NPS)
-CAD	Internal Catalyst Addition Device
-XCAD	External Catalyst Addition Device
-SCP	Solids Charging Port (Ball Valve)
-RC	Reflux Condenser
-RTC	Reflux/Take-Off Condenser

## G Pressure Gage (VGR Required)

-No Symbol	None
-2000	2000 psi / 138 bar
-1000	1000 psi / 69 bar
-600	600 psi / 40 bar
-200	200 psi / 14 bar
-100	100 psi / 7 bar

## H Stand Type

-No Symbol	None
-FS	Floor Stand, Table Support with Manual Lift (Moveable Head)
-FSEH	Floor Stand, Table Support with Electric Hoist (115 VAC) (Moveable Head)
-FSP	Floor Stand with Pneumatic Lift (Fixed Head)

## I Heater Options (require stand)

-No Symbol	None
-C3	Ceramic, 3-zone (moveable head, 5 Gallon only)
-B3	Band Heaters, 3-zone
-WJ	Welded Jacket
-FM	Flexible Mantle Heater, 1-zone (200 °C Max. Temp.)

## J Controller

-No Symbol	None
-4838	PID Control, Ramp & Soak Programming, and Data logging with Software (RS-485 to USB cable not included). For use with one additional display module. (Available only for 10 L/18.75 L with Flexible Mantle Heater or 10L with Band Heaters)
-4848M	With Slave Box, PID Control, Ramp & Soak Programming, and Data logging with Software (RS-485 to USB cable not included). For use with up to three additional display modules. (Recommended for 10 L with Band Heaters. Required for 18.75 L with Ceramic or Band Heaters)

See [Chapter 6](#) for complete list of Controller options.

## K Controller Options (Check all needed)

-PDM	Pressure Display Module
-HTM	High Temperature Cut Off Module
-ETLM	External Temperature Limit Module
-SVM	Solenoid Valve Module (for cooling control)
-A1925E4	RS-485 to USB Converter (required for data logging)
-A1925E6	RS-485 to USB Converter, isolated, 30-ft
-A2208E	RS-485 Daisy Chain for Multiple Controllers (Must be used with A1925E6)
-A3504HC	SpecView Software Package for 4838/4848 Controller

## L Electrical Supply for Heater and/or Controller

-No Symbol	None
-230	230 VAC, Single Phase (Typically 40A supply required)
-400	400-415V 3-Phase "Y"

## M Certifications

-No Symbol	No Certification
-ASME	ASME Documentation
-CE	CE Documentation
-P	Parr Certification

# Gage Block Assemblies

**Parr gage block assemblies combine the functions** of an Inlet / Outlet Valve, a Pressure Gage, and a Safety Rupture Disc into a compact assembly which can be attached to the head of any small vessel with limited head space using a connecting tube. There is a threaded socket in the block for a gas connection with a pressure hose or tubing using a type "A" coned pressure fitting. Coned fittings are also used on the thick-walled tube which connects the block to the pressure vessel. The valve in this assembly controls the gas flow into the vessel and the gage shows the pressure in the vessel when the valve is closed. A rupture disc with a burst rating matched to the gage is installed in the block.

For small vessels with a 1-inch I.D. that can only accommodate a single head port, we offer a version of the 4310A with a 1/16" O.D. thermocouple.

## Two Sizes

These gage block assemblies are made in two styles which differ only in the size of the pressure gage and the size of the tube connection to the pressure vessel. The smaller 4310A Gage Block Assembly is usually furnished with a 3-1/2 inch diameter pressure gage and includes a 3-inch long connecting tube with type "A" coned fitting. This assembly is normally installed on pressure vessels up to 600 mL.

The 4310B Gage Block Assembly has a 4-1/2 inch diameter gage and type "B" coned fitting on a 3-inch long connecting tube. This assembly is normally installed on vessels of 1000 mL and larger.

The gage block, connecting tube and pressure gage on all of these assemblies are normally made of type 316 Stainless Steel, but they can also be made of Alloy 400 on special order. Longer tubes can be furnished on special order.



4310A Gage Block Assembly



4310B Gage Block Assembly

### Ordering Information

Part Number	Description
-4310A	with Type "A" Connector
-4310B	with Type "B" Connector

### Available Gages

Any of the gages shown in this table can be installed on these gage block assemblies.

### Gages for Parr Pressure Vessels

Pressure Range		4-1/2" Diameter	3-1/2" Diameter
psi	bar	Gage Number	Gage Number
0-100	0-7	56HCPA	593HCP1AD
0-200	0-14	56HCPB	593HCP2AD
0-600	0-40	56HCPC	593HCP6AD
0-1000	0-69	56HCPD	593HCPD
0-2000	0-138	56HCPF	593HCPF
0-3000	0-207	56HCPG	593HCPG
0-5000	0-345	56HCPH	593HCP50AD
0-7500	0-517	56HCP75A	N/A
0-10000	0-690	56HCPK	N/A

When ordering, specify the catalog number, pressure gage diameter, range, and if a thermocouple is required.

# Coned Pressure Fittings

**Gage Blocks, pressure hoses and other parts that are frequently removed from a pressure vessel are attached with a coned, socket type connector.** The male segment of a coned fitting consists of a sleeve with a left-hand thread screwed onto a thick-walled tube, plus a compression nut to complete the assembly. When screwed into a mating socket these parts produce a rigid joint which will remain tight over a wide temperature and pressure range, yet the joint can be made and broken repeatedly without destroying the sealing faces. No gasket or sealing tape is required. These fittings have the added advantage of behaving like union fitting,

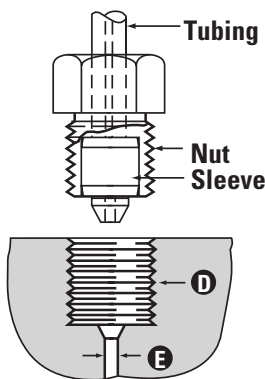

allowing the gage block, connecting tube or hose to remain stationary while the nut is tightened. Parr coned pressure fittings are made in two sizes, identified as types "A" and "B", for 1/4-inch and 3/8-inch tubing, respectively.

### Coned Pressure Fittings

Type	A	B
Tube Size	1/4"	3/8"
Thread (D)	9/16 -18	3/4 -16
Bore (E)	3/32"	1/8"
Nut No.	35HC	326HC
Sleeve No.	40HC	366HC

---

# Notes

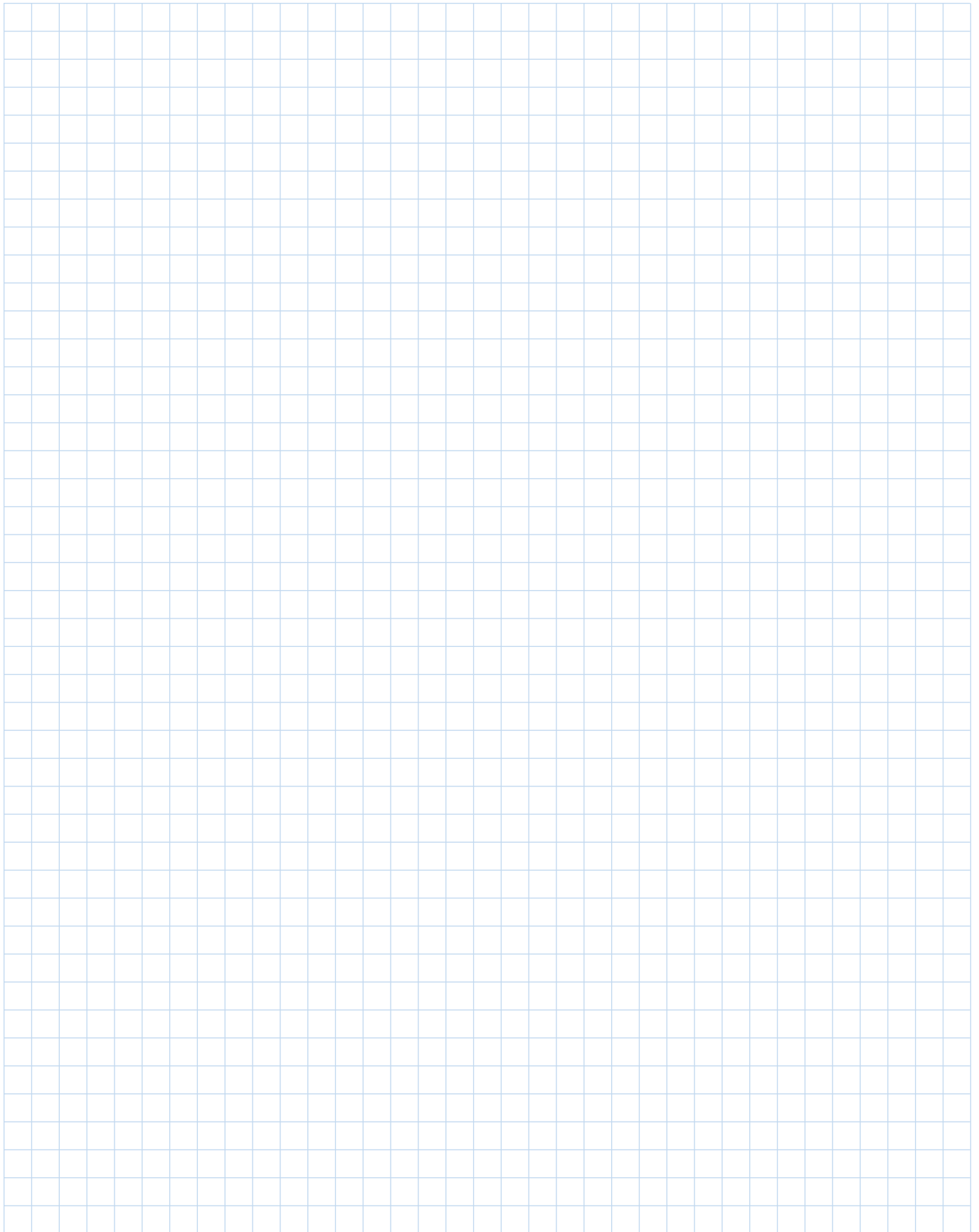



# Notes

A large grid of graph paper for taking notes, consisting of 20 columns and 30 rows of small squares.

# Notes

